

## 100 mA, High Input Voltage LDO Linear Regulators ME6203 Series

### General Description

ME6203 series are low-dropout linear voltage regulators with a built-in voltage reference module, error correction module and phase compensation module. ME6203 series are based on the CMOS process and allow high voltage input with low quiescent current. This series can deliver 100mA output current and allow an input voltage as high as 40V. This series has the function of internal feedback resistor setting from 2.1V to 12V. The output accuracy is  $\pm 2\%$ .

### Typical Application

- Electronic weighbridge
- SCM
- Phones, cordless phones
- Security Products
- Water meters, power meters

### Features

- High output accuracy:  $\pm 2\%$
- Input voltage: up to 40 V
- Output voltage: 2.1V ~ 12V
- Ultra-low quiescent current (Typ.= 3  $\mu$  A)
- Output Current:  $I_{OUT} = 100\text{mA}$   
(When  $V_{IN} = 5.5\text{V}$  and  $V_{OUT} = 3.3\text{V}$ )
- Short-circuit Current: (Typ.= 20mA)
- Low temperature coefficient
- Ceramic capacitor can be used

### Package

- 3-pin SOT89-3 、 SOT23-3 、 TO92

### Typical Application

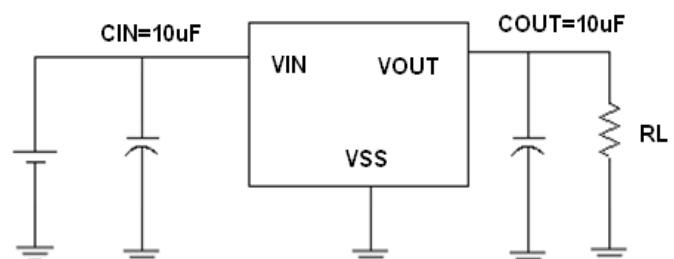

**Suggesting :** The circuit uses the electrolytic capacitors or tantalum capacitors in the best ,when it is applied in the high input voltage.

## Selection Guide

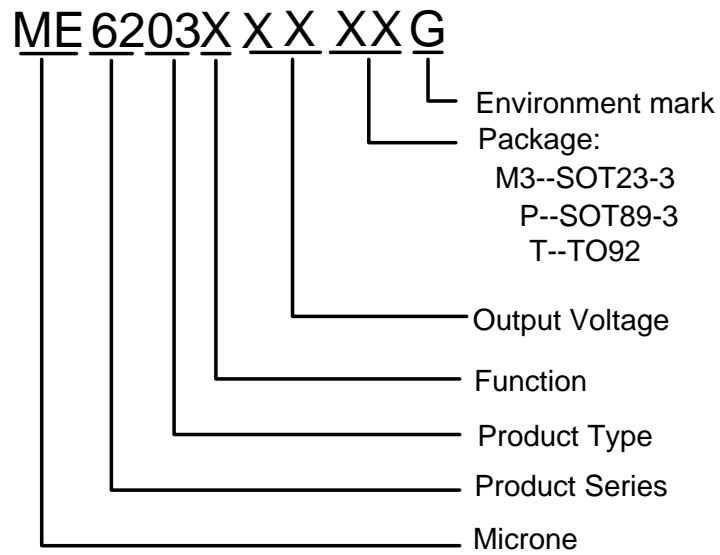

product series	product description
ME6203A30M3G	$V_{OUT} = 3.0V$ ; Package: M3,P,T
ME6203A33M3G	$V_{OUT} = 3.3V$ ; Package: M3,P,T
ME6203A36M3G	$V_{OUT} = 3.6V$ ; Package: M3,P,T
ME6203A50M3G	$V_{OUT} = 5.0V$ ; Package: M3,P,T

## Pin Configuration

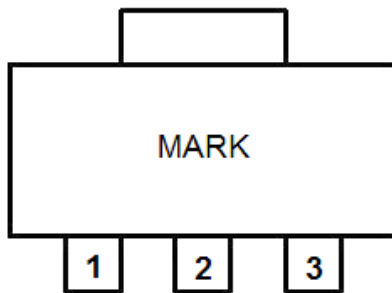

SOT89-3

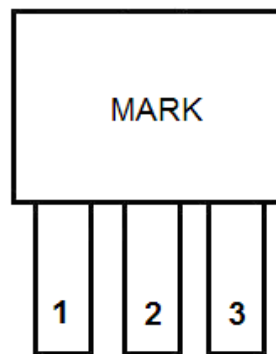

TO92

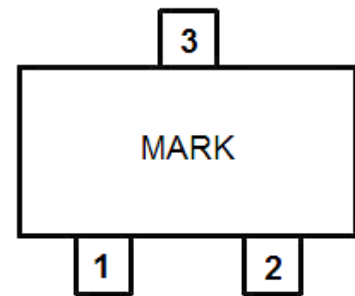

SOT23-3

## Pin Assignment

Pin Number		Pin Name	Functions
SOT89-3 / TO92	SOT23-3		
1	1	$V_{SS}$	Ground
2	3	$V_{IN}$	Power Input
3	2	$V_{OUT}$	Output

## Block Diagram

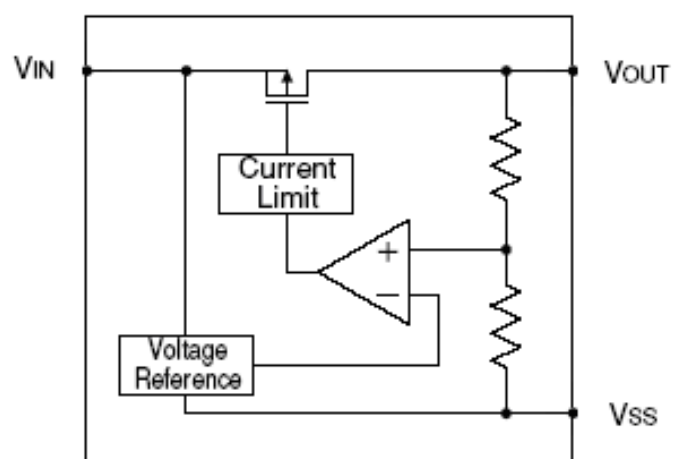

## Absolute Maximum Ratings

Parameter	Symbol	Ratings	Units
Input Voltage	$V_{IN}$	40	V
Output Current	$I_{OUT}$	150	mA
Output Voltage	$V_{OUT}$	$V_{SS}-0.3 \sim V_{IN} + 0.3$	V
Power Dissipation	SOT89-3	500	mW
	TO92	500	
	SOT23-3	300	
Operating Temperature Range	$T_{OPR}$	$-45 \sim +150$	$^{\circ}C$
Storage Temperature Range	$T_{STG}$	$-55 \sim +150$	$^{\circ}C$
Lead Temperature		$260^{\circ}C, 10sec$	

## Electrical Characteristics

### ME6203A30

( $V_{IN} = V_{OUT} + 2.0V$ ,  $C_{IN} = C_L = 10\mu F$ ,  $T_a = 25^{\circ}C$ , unless otherwise noted)

Parameter	Symbol	Conditions	Min.	Typ.	Max.	Units
Output Voltage	$V_{OUT(E)}$ (Note 2)	$I_{OUT} = 10mA$	X 0.98	$V_{OUT(T)}$ (Note 1)	X 1.02	V
Input Voltage	$V_{IN}$		3.0		40	V
Maximum Output Current	$I_{OUT\_max}$	$V_{IN} = V_{OUT} + 2.5V$		100	120	mA
Load Regulation	$\Delta V_{OUT}$	$V_{IN} = V_{OUT} + 2.5V$ , $1mA \leq I_{OUT} \leq 100mA$		30	60	mV
Dropout Voltage (Note 3)	$V_{DIF}$	$I_{OUT} = 10mA$		0.25		V
		$I_{OUT} = 50mA$		1.2		V
Supply Current	$I_{SS}$	$V_{IN} = V_{OUT} + 2V$		3	4	$\mu A$
Line Regulations	$\frac{\Delta V_{OUT}}{\Delta V_{IN} \times V_{OUT}}$	$I_{OUT} = 1mA$ $V_{OUT} + 1V \leq V_{IN} \leq 40V$		0.02	0.1	%/V
Short-circuit Current	$I_{SHORT}$	$V_{OUT} = 0V$		20	40	mA
Temperature Coefficient	$\frac{\Delta V_{OUT}}{V_{OUT} \times \Delta T_a}$	$I_{OUT} = 10mA$ $-40^{\circ}C \leq T_a \leq 85^{\circ}C$		80		ppm/ $^{\circ}C$

## ME6203A33

( $V_{IN} = V_{OUT} + 2.0V$ ,  $C_{IN} = C_L = 10\mu F$ ,  $T_a = 25^\circ C$ , unless otherwise noted)

Parameter	Symbol	Conditions	Min.	Typ.	Max.	Units
Output Voltage	$V_{OUT(E)}$ (Note 2)	$I_{OUT} = 10mA$	X 0.98	$V_{OUT(T)}$ (Note 1)	X 1.02	V
Input Voltage	$V_{IN}$		3.3		40	V
Maximum Output Current	$I_{OUT\_max}$	$V_{IN} = V_{OUT} + 2.2V$		100	120	mA
Load Regulation	$\Delta V_{OUT}$	$V_{IN} = V_{OUT} + 2.2V$ , $1mA \leq I_{OUT} \leq 100mA$		30	60	mV
Dropout Voltage (Note 3)	$V_{DIF}$	$I_{OUT} = 10mA$		0.22		V
		$I_{OUT} = 50mA$		1.1		V
Supply Current	$I_{SS}$	$V_{IN} = V_{OUT} + 2V$		3	4	$\mu A$
Line Regulations	$\frac{\Delta V_{OUT}}{\Delta V_{IN} \times V_{OUT}}$	$I_{OUT} = 1mA$ $V_{OUT} + 1V \leq V_{IN} \leq 40V$		0.04	0.1	%/V
Short-circuit Current	$I_{SHORT}$	$V_{OUT} = 0V$		20	40	mA
Temperature Coefficient	$\frac{\Delta V_{OUT}}{V_{OUT} \times \Delta T_a}$	$I_{OUT} = 10mA$ $-40^\circ C \leq T_a \leq 85^\circ C$		80		ppm/ $^\circ C$

## ME6203A36

( $V_{IN} = V_{OUT} + 2.0V$ ,  $C_{IN} = C_L = 10\mu F$ ,  $T_a = 25^\circ C$ , unless otherwise noted)

Parameter	Symbol	Conditions	Min.	Typ.	Max.	Units
Output Voltage	$V_{OUT(E)}$ (Note 2)	$I_{OUT} = 10mA$	X 0.98	$V_{OUT(T)}$ (Note 1)	X 1.02	V
Input Voltage	$V_{IN}$		3.6		40	V
Maximum Output Current	$I_{OUT\_max}$	$V_{IN} = V_{OUT} + 2.2V$		100	120	mA
Load Regulation	$\Delta V_{OUT}$	$V_{IN} = V_{OUT} + 2.2V$ , $1mA \leq I_{OUT} \leq 100mA$		30	60	mV
Dropout Voltage (Note 3)	$V_{DIF}$	$I_{OUT} = 10mA$		0.20		V
		$I_{OUT} = 50mA$		1.0		V
Supply Current	$I_{SS}$	$V_{IN} = V_{OUT} + 2V$		3	4	$\mu A$
Line Regulations	$\frac{\Delta V_{OUT}}{\Delta V_{IN} \times V_{OUT}}$	$I_{OUT} = 1mA$ $V_{OUT} + 1V \leq V_{IN} \leq 40V$		0.02	0.1	%/V
Short-circuit Current	$I_{SHORT}$	$V_{OUT} = 0V$		20	40	mA
Temperature Coefficient	$\frac{\Delta V_{OUT}}{V_{OUT} \times \Delta T_a}$	$I_{OUT} = 10mA$ $-40^\circ C \leq T_a \leq 85^\circ C$		80		ppm/ $^\circ C$

## ME6203A50

( $V_{IN} = V_{OUT} + 2.0V$ ,  $C_{IN} = C_L = 10\mu F$ ,  $T_a = 25^\circ C$ , unless otherwise noted)

Parameter	Symbol	Conditions	Min.	Typ.	Max.	Units
Output Voltage	$V_{OUT(E)}$ (Note 2)	$I_{OUT} = 10mA$	X 0.98	$V_{OUT(T)}$ (Note 1)	X 1.02	V
Input Voltage	$V_{IN}$		5.0		40	V
Maximum Output Current	$I_{OUT\_max}$	$V_{IN} = V_{OUT} + 2.0V$		150	180	mA
Load Regulation	$\Delta V_{OUT}$	$V_{IN} = V_{OUT} + 2.0V$ , $1mA \leq I_{OUT} \leq 100mA$		33	60	mV
Dropout Voltage (Note 3)	$V_{DIF}$	$I_{OUT} = 10mA$		0.13		V
		$I_{OUT} = 50mA$		0.68		V
Supply Current	$I_{SS}$	$V_{IN} = V_{OUT} + 2V$		3.3	4.5	$\mu A$
Line Regulations	$\frac{\Delta V_{OUT}}{\Delta V_{IN} \times V_{OUT}}$	$I_{OUT} = 1mA$ $V_{OUT} + 1V \leq V_{IN} \leq 40V$		0.03	0.1	%/V
Short-circuit Current	$I_{SHORT}$	$V_{OUT} = 0V$		25	40	mA
Temperature Coefficient	$\frac{\Delta V_{OUT}}{V_{OUT} \times \Delta T_a}$	$I_{OUT} = 10mA$ $-40^\circ C \leq T_a \leq 85^\circ C$		80		ppm/ $^\circ C$

### Note :

- $V_{OUT(T)}$  : Specified Output Voltage
- $V_{OUT(E)}$  : Effective Output Voltage ( ie. The output voltage when " $V_{OUT(T)} + 2.0V$ " is provided at the  $V_{IN}$  pin while maintaining a certain  $I_{OUT}$  value.)
- $V_{DIF}$ :  $V_{IN1} - V_{OUT(E)}$   
 $V_{IN1}$  : The input voltage when  $V_{OUT(E)}$  appears as input voltage is gradually decreased.  
 $V_{OUT(E)}$  = A voltage equal to 98% of the output voltage whenever an amply stabilized  $I_{OUT}$  and  $\{V_{OUT(T)} + 2.2V\}$  is input.

## Type Characteristics

(1) Output Voltage VS. Output Current (  $T_a = 25^\circ\text{C}$  )

**ME6203A33** ( $V_{IN}=V_{OUT}+2.2\text{V}$ )

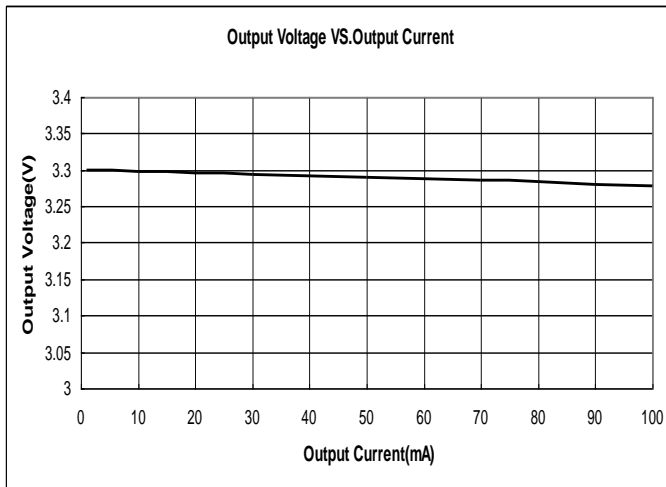

(2) Output Voltage VS. Input Voltage (  $T_a = 25^\circ\text{C}$  )

**ME6203A33**

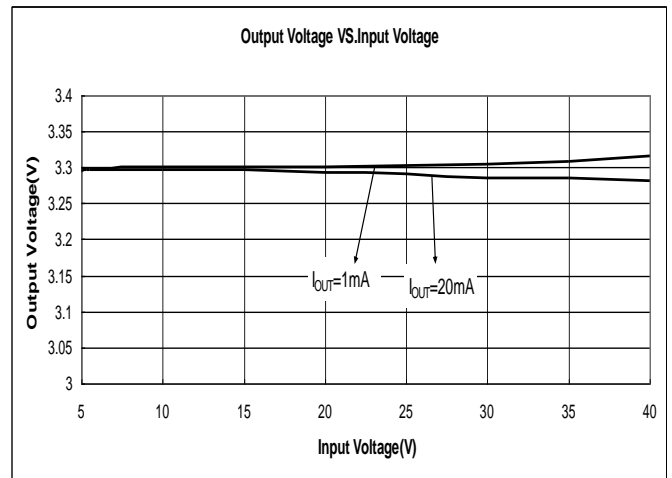

(3) Dropout Voltage VS. Output Current (  $T_a = 25^\circ\text{C}$  )

**ME6203A33**

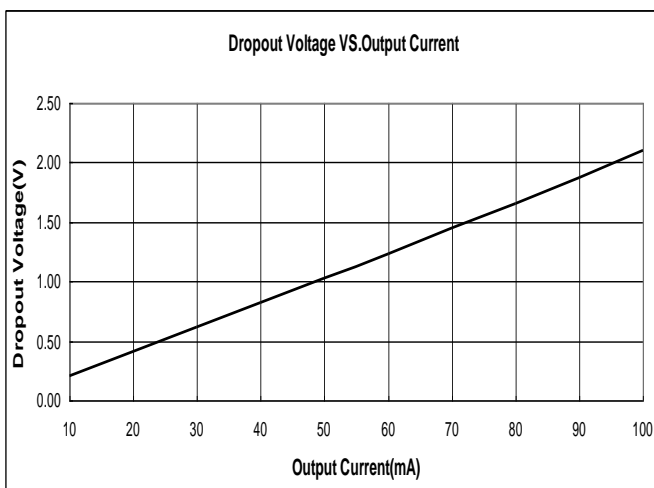

(4) Quiescent Current VS. Input Voltage (  $T_a = 25^\circ\text{C}$  )

**ME6203A33**

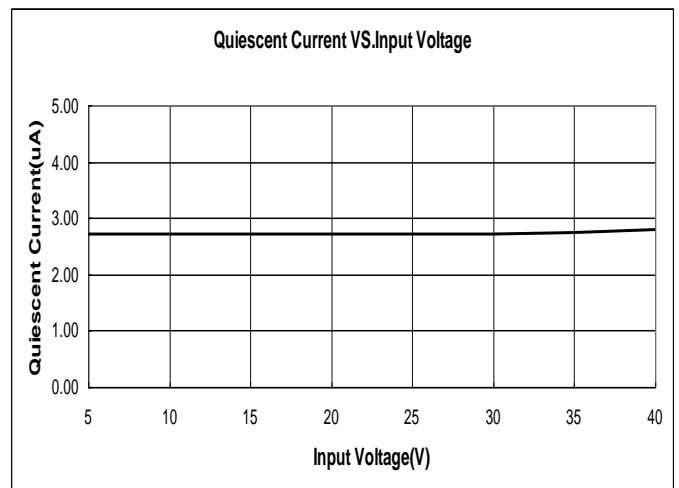

(5) Output Voltage VS. Temperature

**ME6203A33** ( $I_{OUT}=10\text{mA}$ )

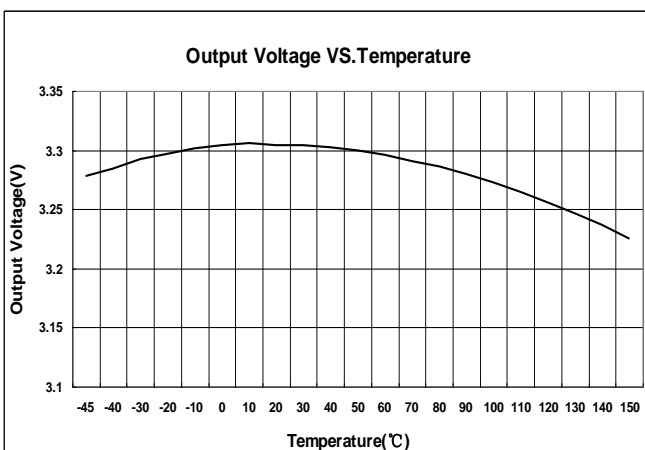

(6) Quiescent Current VS. Temperature

**ME6203A33** ( $V_{IN}=V_{OUT}+2.2\text{V}$ )

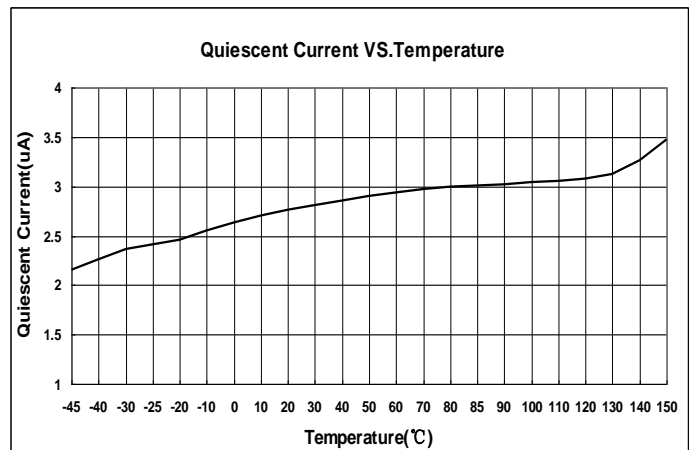

## Packaging Information

● Packaging Type: SOT89-3

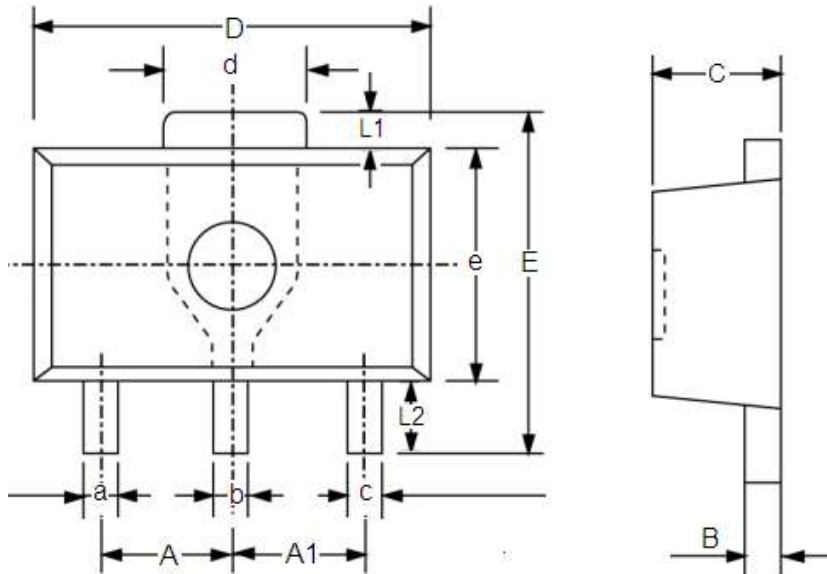

DIM	Millimeters		Inches	
	Min	Max	Min	Max
A	1.4	1.6	0.0551	0.0630
A1	1.4	1.6	0.0551	0.0630
a	0.36	0.48	0.0142	0.0189
b	0.41	0.53	0.0161	0.0209
c	0.36	0.48	0.0142	0.0189
d	1.4	1.75	0.0551	0.0689
B	0.38	0.43	0.015	0.0169
C	1.4	1.6	0.0551	0.0630
D	4.4	4.6	0.1732	0.181
E	-	4.25	-	0.1673
e	2.4	2.6	0.0945	0.1023
L1	0.4	-	0.0157	-
L2	0.8	-	0.0315	-



● Packaging Type: TO92

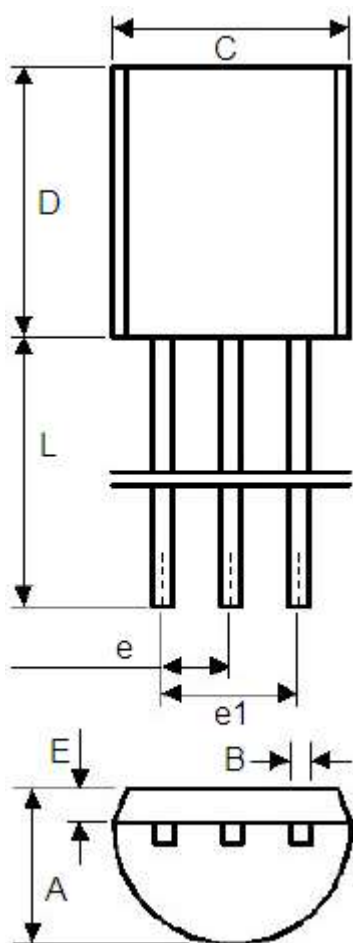

	Min	Max	Min	Max
A	3.4	3.8	0.13386	0.1496
B	0.3	0.5	0.0118	0.0197
C	4.4	4.8	0.1732	0.189
D	4.4	4.8	0.1732	0.189
E	0.9	1.5	0.0354	0.059
e	1.17	1.37	0.046	0.0539
e1	2.39	2.69	0.094	0.1059
L	12	16	0.4724	0.6299

● Packaging Type: SOT23-3

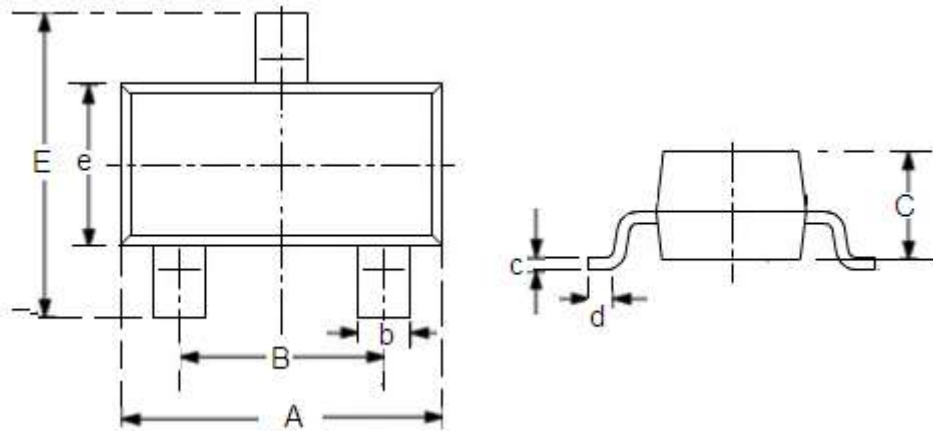

DIM	Millimeters		Inches	
	Min	Max	Min	Max
A	2.7	3.1	0.1063	0.122
B	1.7	2.1	0.0669	0.0827
b	0.35	0.5	0.0138	0.0197
C	1.0	1.2	0.0394	0.0472
c	0.1	0.25	0.0039	0.0098
d	0.2	-	0.0079	-
E	2.6	3.0	0.1023	0.1181
e	1.5	1.8	0.059	0.0708

- The information described herein is subject to change without notice.
- Nanjing Micro One Electronics Inc is not responsible for any problems caused by circuits or diagrams described herein whose related industrial properties, patents, or other rights belong to third parties. The application circuit examples explain typical applications of the products, and do not guarantee the success of any specific mass-production design.
- Use of the information described herein for other purposes and/or reproduction or copying without the express permission of Nanjing Micro One Electronics Inc is strictly prohibited.
- The products described herein cannot be used as part of any device or equipment affecting the human body, such as exercise equipment, medical equipment, security systems, gas equipment, or any apparatus installed in airplanes and other vehicles, without prior written permission of Nanjing Micro One Electronics Inc.
- Although Nanjing Micro One Electronics Inc exerts the greatest possible effort to ensure high quality and reliability, the failure or malfunction of semiconductor products may occur. The user of these products should therefore give thorough consideration to safety design, including redundancy, fire-prevention measures, and malfunction prevention, to prevent any accidents, fires, or community damage that may ensue.

## X-ON Electronics

Largest Supplier of Electrical and Electronic Components

*Click to view similar products for [LDO Voltage Regulators](#) category:*

*Click to view products by [Micro One](#) manufacturer:*

Other Similar products are found below :

[AP7363-SP-13](#) [L79M05TL-E](#) [AP7362-HA-7](#) [PT7M8202B12TA5EX](#) [TCR3DF185,LM\(CT](#) [TCR3DF45,LM\(CT](#) [TLE4473G V52](#) [059985X](#)  
[NCP4687DH15T1G](#) [701326R](#) [NCV8170AXV250T2G](#) [AP7315-25W5-7](#) [AP2111H-1.2TRG1](#) [ZLDO1117QK50TC](#) [AZ1117ID-ADJTRG1](#)  
[TCR3DG12,LF](#) [MIC5514-3.3YMT-T5](#) [SCD7912BTG](#) [NCP154MX180270TAG](#) [SCD33269T-5.0G](#) [NCV8170BXV330T2G](#)  
[NCV8170BMX330TCG](#) [NCV8170AMX120TCG](#) [NCP706ABMX300TAG](#) [NCP153MX330180TCG](#) [NCP114BMX075TCG](#) [MC33269T-3.5G](#)  
[CAT6243-ADJCMT5T](#) [TCR3DG33,LF](#) [TCR4DG35,LF](#) [TAR5S15U\(TE85L,F\)](#) [TAR5S18U\(TE85L,F\)](#) [TCR3UG19A,LF](#) [TCR4DG105,LF](#)  
[MPQ2013AGG-5-P](#) [NCV8170AMX360TCG](#) [TLE4268GSXUMA2](#) [NCP715SQ15T2G](#) [MIC5317-3.0YD5-T5](#) [NCV563SQ18T1G](#)  
[NCP715MX30TBG](#) [NCV8702MX25TCG](#) [NCV8170BXV120T2G](#) [MIC5317-1.2YD5-T5](#) [NCV8170AMX150TCG](#) [NCV8170BMX150TCG](#)  
[AP2213D-3.3TRG1](#) [NCV8170BMX120TCG](#) [NCV8170BMX310TCG](#) [NCV8170BMX360TCG](#)