



150 mA, high input voltage LDO Linear Regulators ME6208 Series

General Description

ME6208 series are low-dropout linear voltage regulators with a built-in voltage reference module, error correction module and phase compensation module. ME6208 series are based on the CMOS process and allow high voltage input with low quiescent current. This series has the function of internal feedback resistor setting from 2.1 to 5.0V. The two output voltage accuracies are: $\pm 1\%$ ($V_{OUT} = 3.0V, 3.3V, 5.0V$) and $\pm 2\%$ (other output voltages).

Typical Application

- Electronic weighbridge
- SCM
- Phones, cordless phones
- Security Products
- Water meters, power meters

Features

- High output accuracy:
 - $\pm 1\%$ ($V_{OUT} = 3.0V, 3.3V, 5.0V$)
 - $\pm 2\%$ (Others)
- Input voltage: up to 18 V
- Output voltage: 2.1 V ~ 5.0V
- Ultra-low quiescent current (Typ. = 3 μ A)
- Output Current: $I_{out} = 200mA$
(When $V_{in} = 7V$ and $V_{out} = 5V$)
- Importation good stability: Typ. 0.05% / V
- Low temperature coefficient
- Ceramic capacitor can be used

Package

- 3-pin SOT23-3、SOT89-3、TO92

Typical Application Circuit

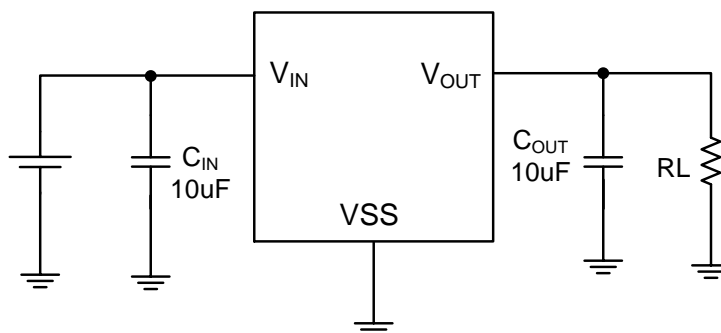

Selection Guide

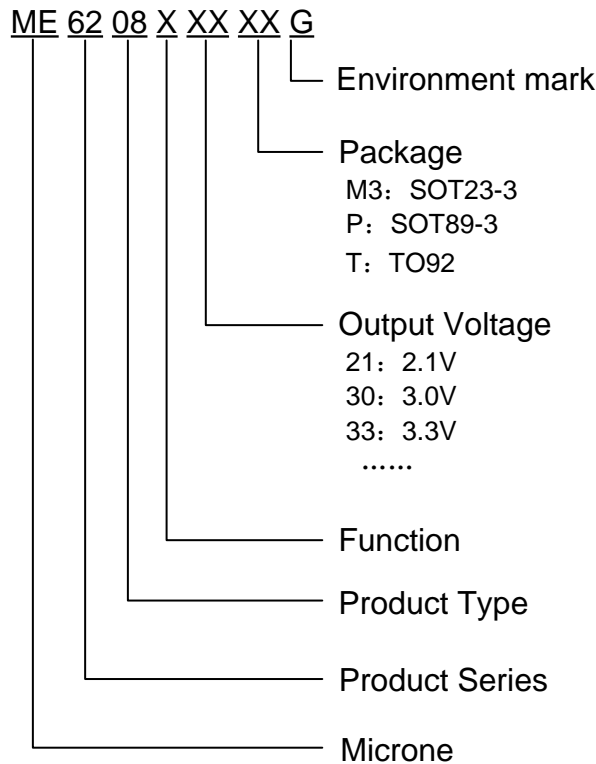

product series	product description
ME6208A21M3G	$V_{OUT} = 2.1V \pm 2\%$; Package: SOT23-3
ME6208A30M3G	$V_{OUT} = 3.0V \pm 1\%$; Package: SOT23-3
ME6208A30PG	$V_{OUT} = 3.0V \pm 1\%$; Package: SOT89-3
ME6208A33M3G	$V_{OUT} = 3.3V \pm 1\%$; Package: SOT23-3
ME6208A33TG	$V_{OUT} = 3.3V \pm 1\%$; Package: TO92
ME6208A36M3G	$V_{OUT} = 3.6V \pm 2\%$; Package: SOT23-3
ME6208A40PG	$V_{OUT} = 4.0V \pm 2\%$; Package: SOT89-3
ME6208A44M3G	$V_{OUT} = 4.4V \pm 2\%$; Package: SOT23-3
ME6208A50M3G	$V_{OUT} = 5.0V \pm 1\%$; Package: SOT23-3
ME6208A50TG	$V_{OUT} = 5.0V \pm 1\%$; Package: TO92

NOTE: At present ,there are seven kinds of voltage value:
2.1V、3.0V、3.3V、3.6V、4.0V、4.4V、5.0V。
If you need other voltage and package, please contact our sales staff。

Pin Configuration

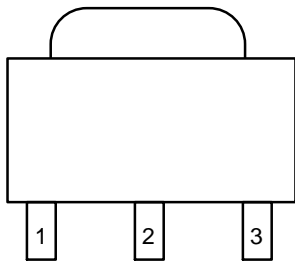

SOT89-3

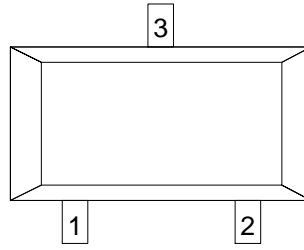

SOT23-3

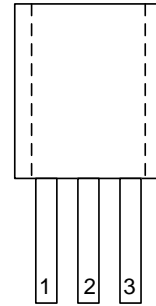

TO92

Pin Assignment

Pin Number		Pin Name	Functions
SOT89-3 / TO92	SOT23-3		
1	1	V_{SS}	Ground
2	3	V_{IN}	Power Input
3	2	V_{OUT}	Output

Block Diagram

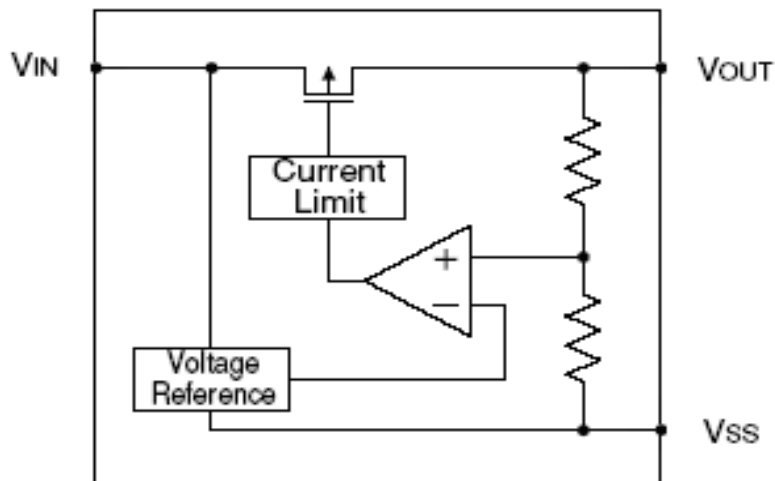

Absolute Maximum Ratings

Parameter		Symbol	Ratings	Units
Input Voltage		V_{IN}	18	V
Output Current		I_{OUT}	250	mA
Output Voltage		V_{OUT}	$V_{SS}-0.3 \sim V_{IN} + 0.3$	V
Power Dissipation	SOT89-3	P_D	1.25	W
	TO92		0.83	
	SOT23-3		0.54	
Thermal resistance	SOT89-3	θ_{JA}	100	°C/W
	TO92		150	
	SOT23-3		230	
Operating Temperature Range		T_{OPR}	-45 ~ +85	°C
Storage Temperature Range		T_{STG}	-55 ~ +150	°C
Lead Temperature			260°C, 10sec	

Electrical Characteristics

($V_{IN} = V_{OUT} + 2.0V$, $C_{IN} = C_L = 10\mu F$, $T_a = 25^\circ C$, unless otherwise noted)

Parameter	Symbol	Conditions	Min.	Typ.	Max.	Units	
Output Voltage	$V_{OUT(E)}$ (Note 2)	$I_{OUT} = 10mA$, $V_{IN} = V_{OUT} + 2V$	$V_{OUT} = 3.0V, 3.3V, 5.0V$	X 0.99	$V_{OUT(T)}$ (Note 1)	X 1.01	V
			$V_{OUT} = \text{others}$	X 0.98	$V_{OUT(T)}$ (Note 1)	X 1.02	
Input Voltage	V_{IN}				18	V	
Maximum Output Current	I_{OUT_max}	$V_{IN} = V_{OUT} + 2V$	150			mA	
Load Regulation	ΔV_{OUT}	$V_{IN} = V_{OUT} + 2V$, $1mA \leq I_{OUT} \leq 100mA$		10		mV	
Dropout Voltage (Note 3)	V_{dif1}	$I_{OUT} = 50mA$		250		mV	
	V_{dif2}	$I_{OUT} = 100mA$		500		mV	
	V_{dif3}	$I_{OUT} = 200mA$		1000		mV	
Supply Current	I_{SS}	$V_{IN} = V_{OUT} + 2V$		3	5	μA	
Line Regulations	$\frac{\Delta V_{OUT}}{\Delta V_{IN} \times V_{OUT}}$	$I_{OUT} = 10mA$ $V_{OUT} + 2V \leq V_{IN} \leq 18V$		0.05		%/V	

Note :

- $V_{OUT(T)}$: Specified Output Voltage
- $V_{OUT(E)}$: Effective Output Voltage (ie. The output voltage when " $V_{OUT(T)} + 2.0V$ " is provided at the Vin pin while maintaining a certain Iout value.)
- V_{DIF} : $V_{IN1} - V_{OUT(E)'}'$
 V_{IN1} : The input voltage when $V_{OUT(E)'}'$ appears as input voltage is gradually decreased.
 $V_{OUT(E)'}'$ = A voltage equal to 98% of the output voltage whenever an amply stabilized Iout and $\{V_{OUT(T)} + 2.0V\}$ is input.

Precautions

- During the test, if AC/DC power supply and the ceramic chip capacitors collocation is used, there may be serious voltage spike phenomenon instantaneously. When the power supply access to 16V, the voltage is rushed to about 30V instantaneously. Because of exceeding the limit voltage of chip, the chip is damaged. If you string a small resistance of 1 ohm in the input end during the test, the peak phenomenon can be avoided.
- In the test, there is serious burr phenomenon only when the AC/DC power is used with ceramic chip capacitors. But electrolytic capacitors and tantalum capacitance won't appear above phenomenon. Please be sure to pay attention to this point when you use AC/DC power.
- In normal use, when any type of capacitor is used with battery or the supply of fire power, the above phenomenon doesn't occur.

Type Characteristics

(1) Output Current VS. Output Voltage ($T_a = 25\text{ }^\circ\text{C}$)

ME6208A50

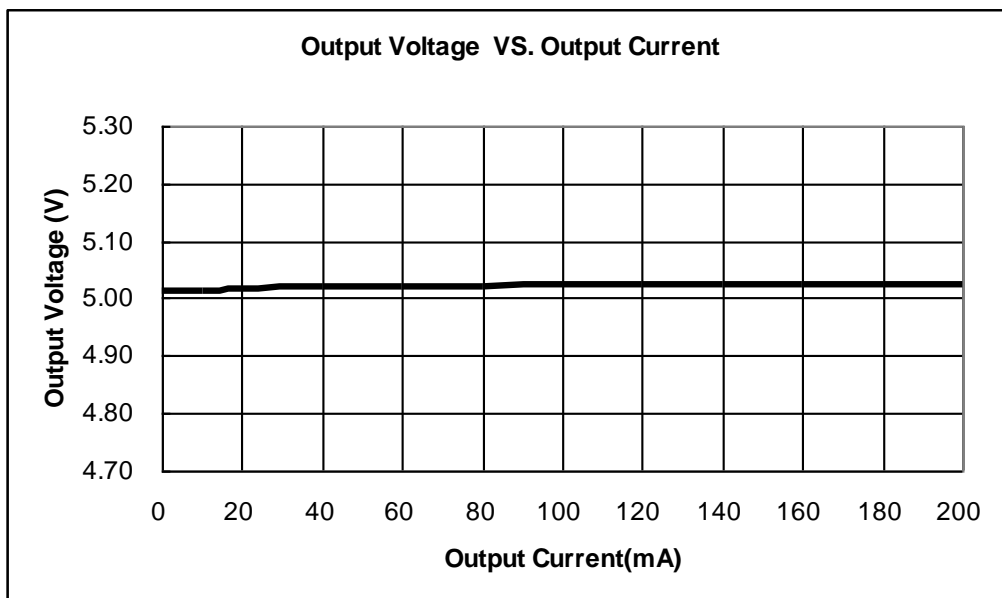

(2) Input Voltage VS. Output Voltage ($T_a = 25\text{ }^\circ\text{C}$)

ME6208A50

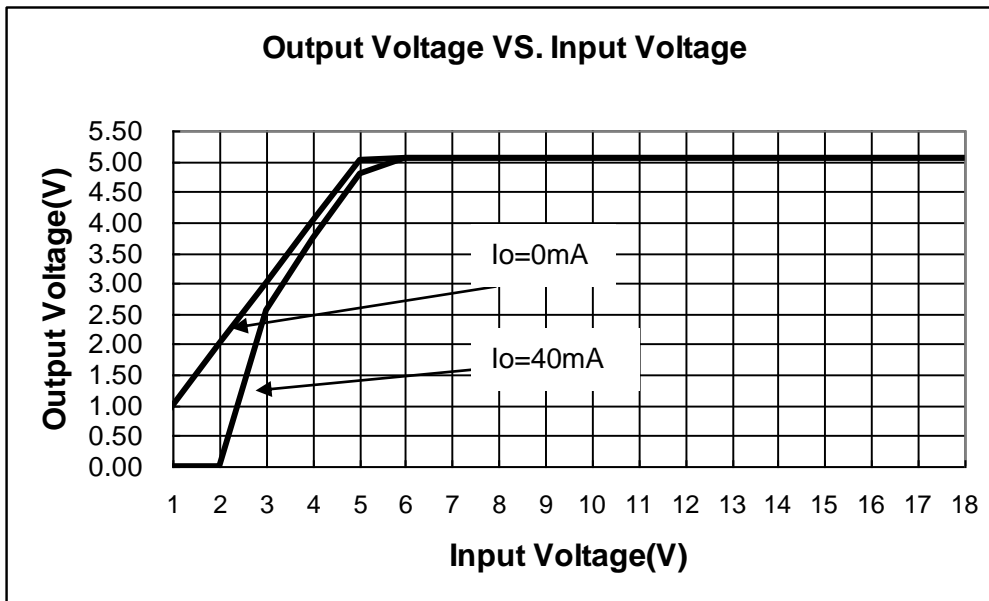

(3) Output Current VS. Dropout Voltage ($T_a = 25\text{ }^\circ\text{C}$)

ME6208A50

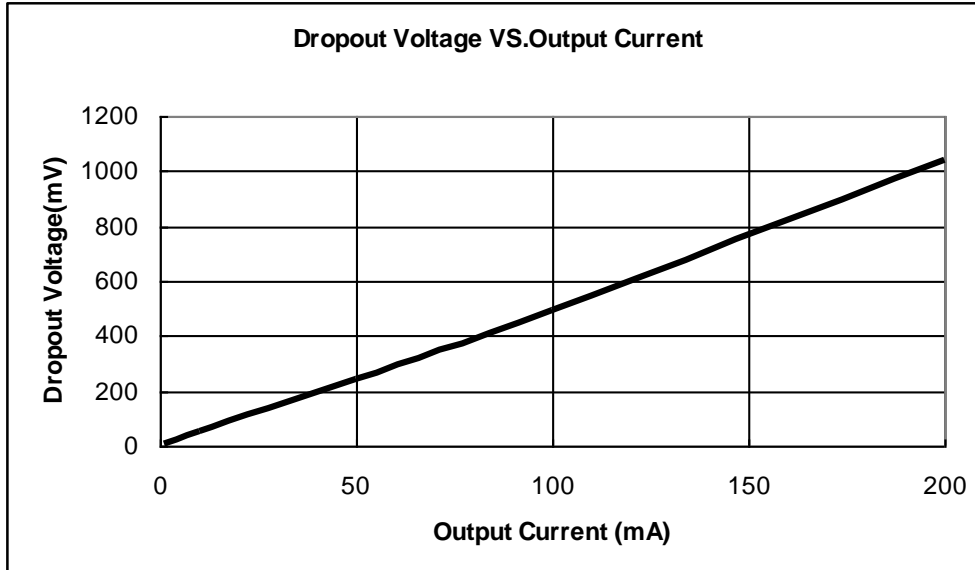

(4) Input Voltage VS. Supply Current (Ta = 25 °C)

ME6208A50

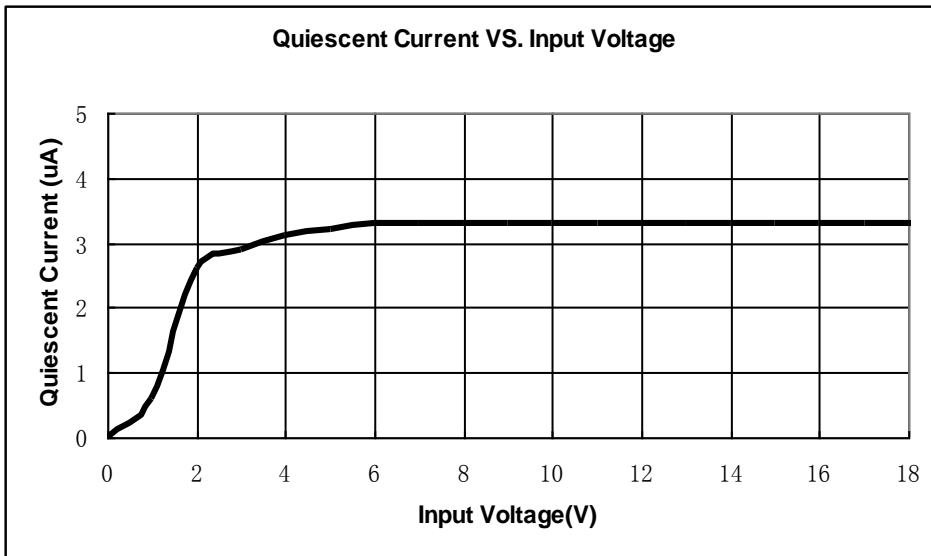

(5) Output Voltage VS. Temperature

ME6208A33

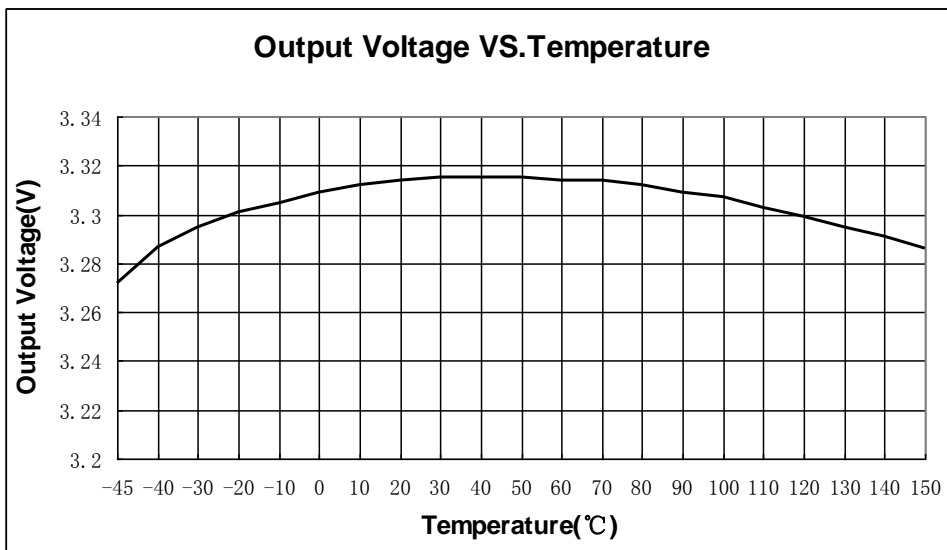

Packaging Information

- Packaging Type: SOT23-3

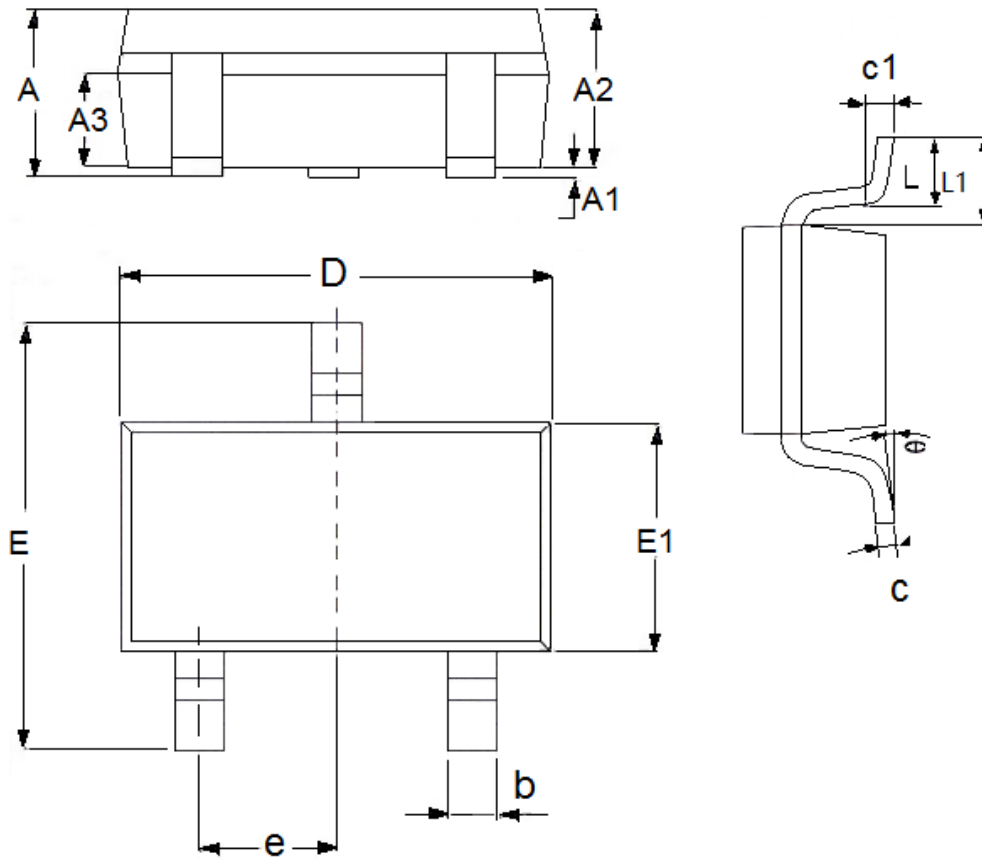

DIM	Millimeters		Inches	
	Min	Max	Min	Max
A	1.05	1.45	0.0413	0.0571
A1	0	0.15	0.0000	0.0059
A2	0.9	1.3	0.0354	0.0512
A3	0.6	0.7	0.0236	0.0276
b	0.25	0.5	0.0098	0.0197
c	0.1	0.25	0.0039	0.0098
D	2.8	3.1	0.1102	0.1220
E	2.6	3.1	0.1023	0.1220
E1	1.5	1.8	0.0591	0.0709
e	0.95(TYP)		0.0374(TYP)	
L	0.25	0.6	0.0098	0.0236
L1	0.59(TYP)		0.0232(TYP)	
theta	0	8°	0.0000	8°
c1	0.2(TYP)		0.0079(TYP)	

● Packaging Type: SOT89-3

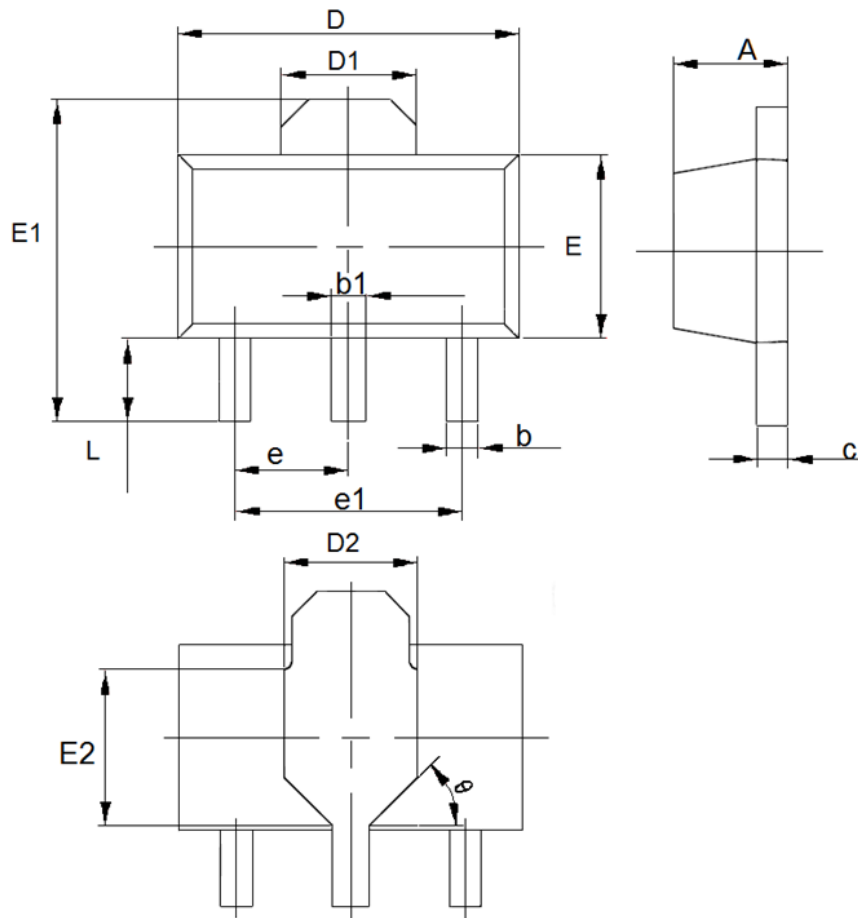

DIM	Millimeters		Inches	
	Min	Max	Min	Max
A	1.4	1.6	0.0551	0.063
b	0.32	0.52	0.0126	0.0205
b1	0.4	0.58	0.0157	0.0228
c	0.35	0.45	0.0138	0.01772
D	4.4	4.6	0.1732	0.1811
D1	1.55(TYP)		0.061(TYP)	
D2	1.75(TYP)		0.0689(TYP)	
e1	3(TYP)		0.1181(TYP)	
E	2.3	2.6	0.0906	0.1023
E1	3.94	4.4	0.1551	0.1732
E2	1.9(TYP)		0.0748(TYP)	
e	1.5(TYP)		0.0591(TYP)	
L	0.8	1.2	0.0315	0.0472
θ	45°		45°	

● Packaging Type:TO-92

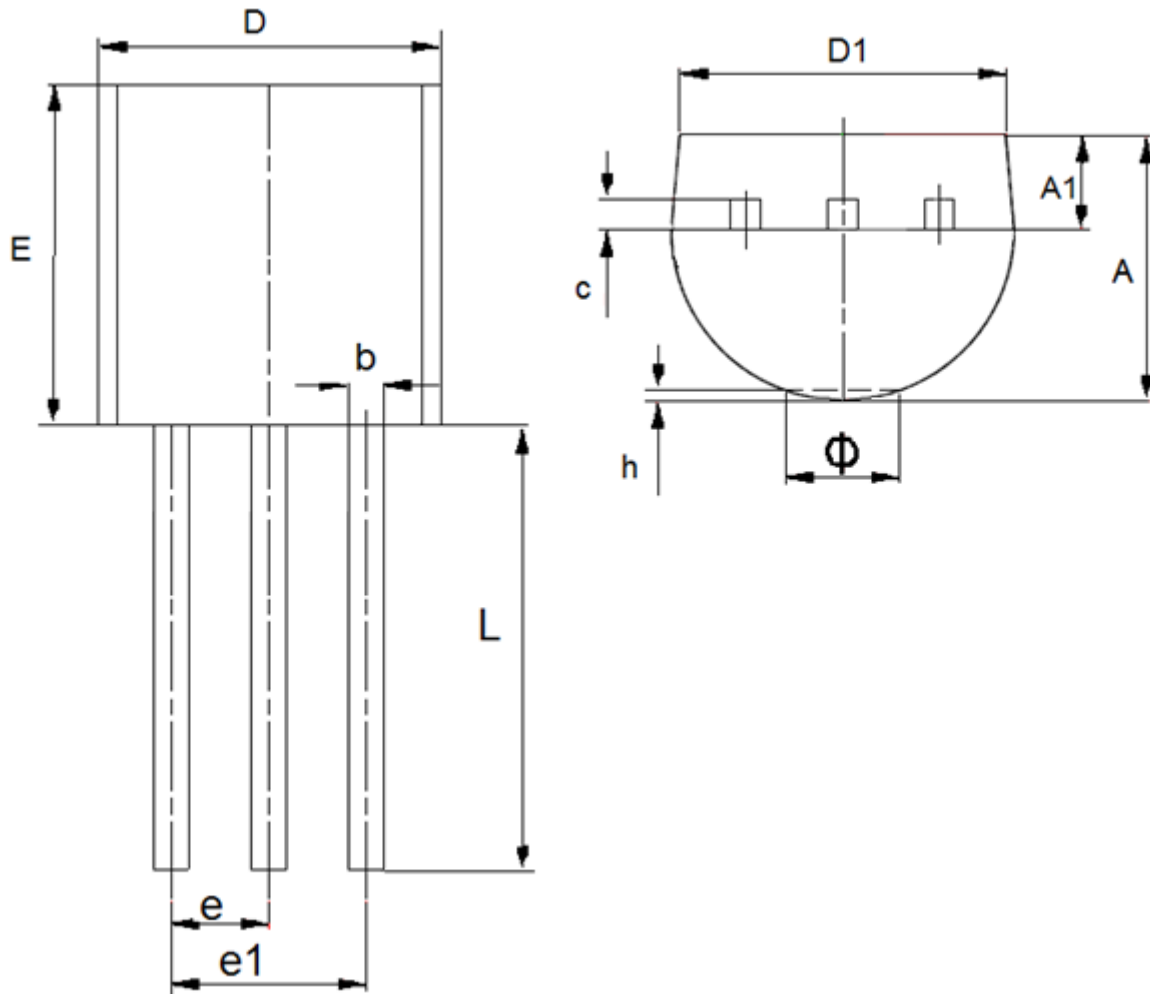

DIM	Millimeters		Inches	
	Min	Max	Min	Max
A	3.3	3.7	0.1299	0.1457
A1	1.1	1.4	0.0433	0.0551
b	0.38	0.55	0.015	0.0217
c	0.36	0.51	0.0142	0.0201
D	4.3	4.7	0.1693	0.185
D1	3.43	—	0.135	—
E	4.3	4.7	0.1693	0.185
e	1.27		0.05	
e1	2.44	2.64	0.0961	0.1039
L	14.1	14.5	0.5551	0.5709
h	0	0.38	0	0.015
Φ	—	1.6	—	0.063

- The information described herein is subject to change without notice.
- Nanjing Micro One Electronics Inc is not responsible for any problems caused by circuits or diagrams described herein whose related industrial properties, patents, or other rights belong to third parties. The application circuit examples explain typical applications of the products, and do not guarantee the success of any specific mass-production design.
- Use of the information described herein for other purposes and/or reproduction or copying without the express permission of Nanjing Micro One Electronics Inc is strictly prohibited.
- The products described herein cannot be used as part of any device or equipment affecting the human body, such as exercise equipment, medical equipment, security systems, gas equipment, or any apparatus installed in airplanes and other vehicles, without prior written permission of Nanjing Micro One Electronics Inc.
- Although Nanjing Micro One Electronics Inc exerts the greatest possible effort to ensure high quality and reliability, the failure or malfunction of semiconductor products may occur. The user of these products should therefore give thorough consideration to safety design, including redundancy, fire-prevention measures, and malfunction prevention, to prevent any accidents, fires, or community damage that may ensue.

X-ON Electronics

Largest Supplier of Electrical and Electronic Components

Click to view similar products for [Linear Voltage Regulators](#) category:

Click to view products by [Micro One](#) manufacturer:

Other Similar products are found below :

[LV56831P-E](#) [LV5684PVD-XH](#) [MCDTSA6-2R](#) [L7815ACV-DG](#) [PQ3DZ53U](#) [LV56801P-E](#) [TLE42794G](#) [L78L05CZ/1SX](#) [L78LR05DL-MA-E](#) [636416C](#) [714954EB](#) [BA033LBSG2-TR](#) [LV5680P-E](#) [L78M15CV-DG](#) [L79M05T-E](#) [TLS202A1MBVHTSA1](#) [L78LR05D-MA-E](#) [NCV317MBTG](#) [NTE7227](#) [LV5680NPVC-XH](#) [LT1054CN8](#) [MP2018GZD-5-Z](#) [MP2018GZD-33-Z](#) [MIC5281-3.3YMM](#) [MC78L06BP-AP](#) [TA48LS05F\(TE85L,F\)](#) [TA78L12F\(TE12L,F\)](#) [TC47BR5003ECT](#) [TCR2LN12,LF\(S](#) [TCR2LN28,LF\(S](#) [TCR2LN30,LF\(S](#) [TCR3DF295,LM\(CT](#) [TCR3DF40,LM\(CT](#) [BA178M20CP-E2](#) [L78M12ABDT](#) [LM7812SX/NOPB](#) [LR645N3-G-P003](#) [LR645N3-G-P013](#) [ZXTR2005P5-13](#) [SCD7812BTG](#) [TCR3DF335,LM\(CT](#) [ZXTR2012K-13](#) [TLE42994E V33](#) [ZXTR2008K-13](#) [ZXTR2005K-13](#) [L88R05DL-E](#) [ADP3300ARTZ-2.7RL7](#) [LM120K-15/883](#) [IFX54441LDVXUMA1](#) [LM317D2T-TR](#)