

Low Power Consumption LDO ME6209 Series

General Description

The ME6209 series are a group of positive voltage output, three –pin regulator, that provide a high current even when the input/output Voltage differential is small. Low power consumption and high accuracy is achieved through CMOS technology. They allow input voltages as high as 18V.

Features

- Ultra low quiescent current: 3.0uA(typ)
- High input voltage (up to 18V)
- Low dropout voltage :80mV@Iout=40mA (V_{OUT}=3.3V)
- Output voltage accuracy: ±2%
- Maximum output current: 250mA (within max.power dissipation,V_{OUT} =3.3V)
- Low temperature coefficient

Typical Application

- Cameras, video recorders
- Voltage regulator for microprocessor
- Voltage regulator for LAN cards
- Wireless communication equipment
- Audio/Video equipment

Package

- 3-pin SOT23-3、SOT89-3、TO-92

Typical Application Circuit

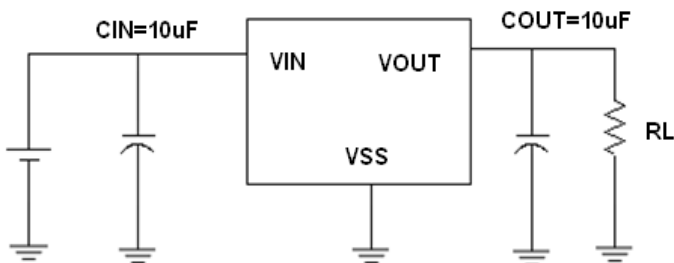

Selection Guide

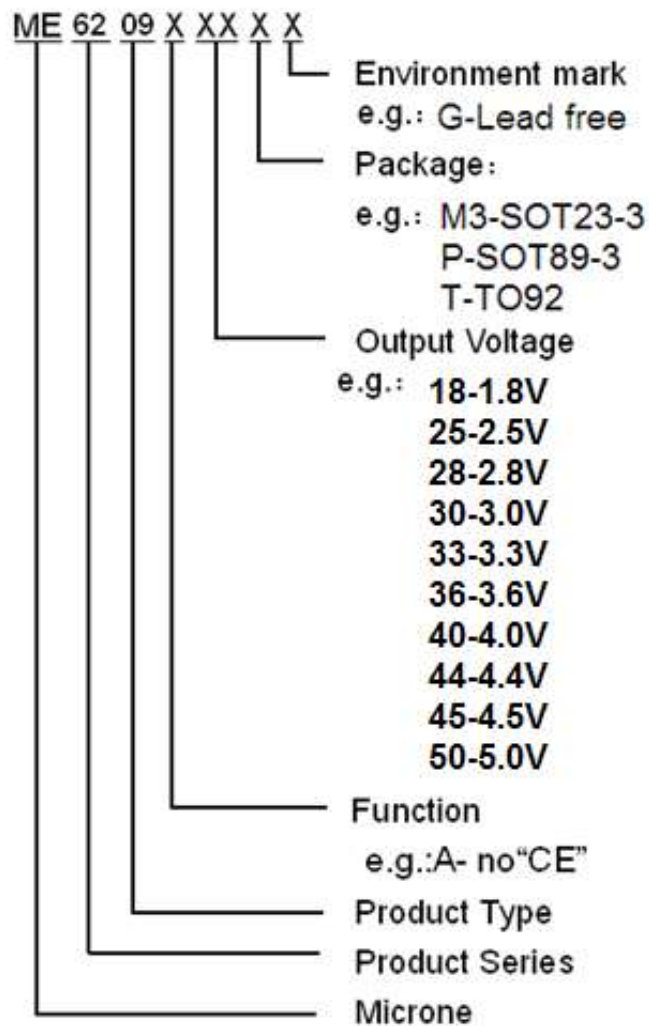

Pin Configuration

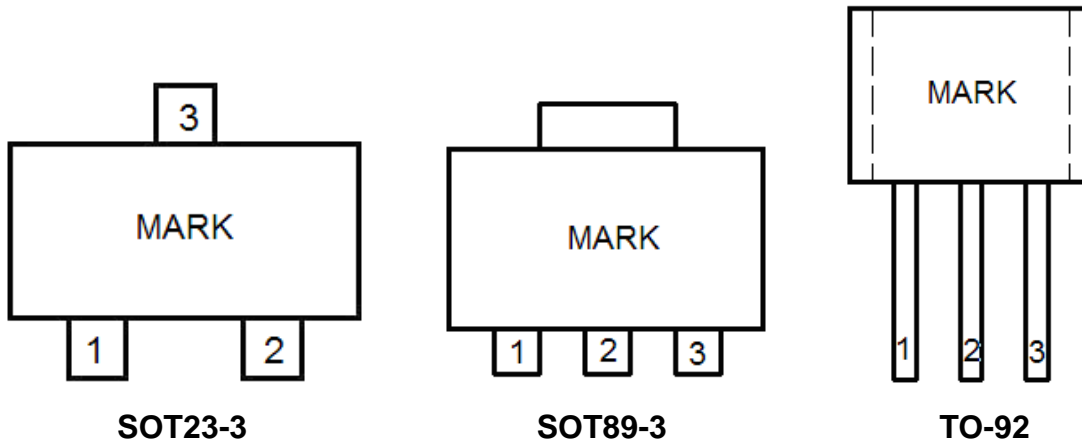

Pin Assignment

Pin Num		Symbol	Function
SOT89-3/TO-92	SOT23-3		
1	1	V_{SS}	Ground
2	3	V_{IN}	Input
3	2	V_{OUT}	Output

Block Diagram

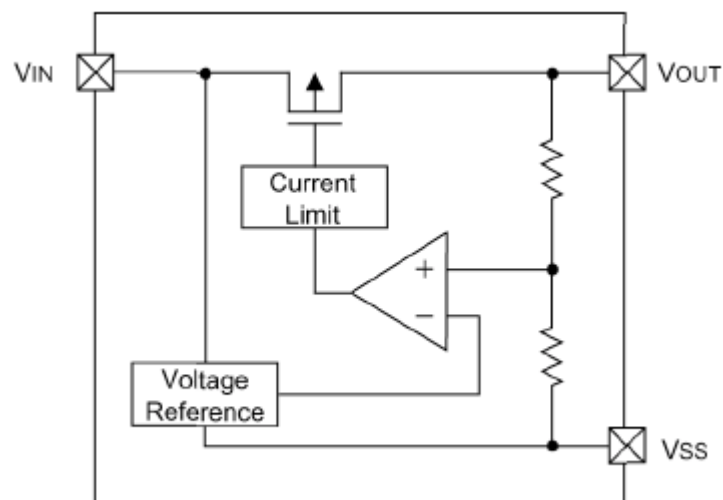

Absolute Maximum Ratings

Parameter	Symbol	Ratings	Units
Input Voltage	V_{IN}	18	V
Output Voltage	V_{OUT}	$V_{SS}-0.3 \sim V_{IN} + 0.3$	V
Output Current	I_{OUT}	500	mA
Operating Temperature Range	T_{OPR}	-45 ~ +150	°C
Storage Temperature Range	T_{STG}	-55 ~ +140	°C
Power Dissipation	SOT89-3	500	mW
	TO-92	500	
	SOT23-3	300	

Electrical Characteristics

ME6209A18

($V_{IN} = V_{OUT} + 1.0V$, $C_{IN} = C_L = 10\mu F$, $T_a = 25^\circ C$, unless otherwise noted)

Parameter	Symbol	Conditions	Min.	Typ.	Max.	Units
Output Voltage	$V_{OUT(E)}$ (Note 2)	$I_{OUT} = 40mA$, $V_{IN} = V_{OUT} + 1V$	X 0.98	$V_{OUT(T)}$ (Note 1)	X 1.02	V
Input Voltage	V_{IN}				18	V
Maximum Output Current	I_{OUT_max}	$V_{IN} = V_{OUT} + 1V$		250	280	mA
Load Regulation	ΔV_{OUT}	$V_{IN} = V_{OUT} + 1V$, $1mA \leq I_{OUT} \leq 60mA$		10	40	mV
Dropout Voltage (Note 3)	V_{DIF}	$I_{OUT} = 40mA$		150		mV
Supply Current	I_{SS}	$V_{IN} = V_{OUT} + 1V$		3	5	μA
Line Regulations	$\frac{\Delta V_{OUT}}{\Delta V_{IN} \times V_{OUT}}$	$I_{OUT} = 40mA$ $V_{OUT} + 1V \leq V_{IN} \leq 18V$		0.1	0.2	%/V
$\Delta V_{OUT} / \Delta T_a$	Temperature Coefficient	$V_{IN} = V_{OUT} + 1V$, $I_{OUT} = 40mA$ $-40^\circ C < T_a < 85^\circ C$		± 0.7		mV/°C

ME6209A25

($V_{IN} = V_{OUT} + 1.0V$, $C_{IN} = C_L = 10\mu F$, $T_a = 25^\circ C$, unless otherwise noted)

Parameter	Symbol	Conditions	Min.	Typ.	Max.	Units
Output Voltage	$V_{OUT}(E)$ (Note 2)	$I_{OUT} = 40mA$, $V_{IN} = V_{OUT} + 1V$	X 0.98	$V_{OUT}(T)$ (Note 1)	X 1.02	V
Input Voltage	V_{IN}				18	V
Maximum Output Current	I_{OUT_max}	$V_{IN} = V_{OUT} + 1V$		250	300	mA
Load Regulation	ΔV_{OUT}	$V_{IN} = V_{OUT} + 1V$, $1mA \leq I_{OUT} \leq 60mA$		10	40	mV
Dropout Voltage (Note 3)	V_{DIF}	$I_{OUT} = 40mA$		100		mV
Supply Current	I_{SS}	$V_{IN} = V_{OUT} + 1V$		3	5	μA
Line Regulations	$\frac{\Delta V_{OUT}}{\Delta V_{IN}} \times V_{OUT}$	$I_{OUT} = 40mA$ $V_{OUT} + 1V \leq V_{IN} \leq 18V$		0.1	0.2	%/V
$\Delta V_{OUT} / \Delta T_a$	Temperature Coefficient	$V_{IN} = V_{OUT} + 1V$, $I_{OUT} = 40mA$ $-40^\circ C < T_a < 85^\circ C$		± 0.7		mV/ $^\circ C$

ME6209A30

($V_{IN} = V_{OUT} + 1.0V$, $C_{IN} = C_L = 10\mu F$, $T_a = 25^\circ C$, unless otherwise noted)

Parameter	Symbol	Conditions	Min.	Typ.	Max.	Units
Output Voltage	$V_{OUT}(E)$ (Note 2)	$I_{OUT} = 40mA$, $V_{IN} = V_{OUT} + 1V$	X 0.98	$V_{OUT}(T)$ (Note 1)	X 1.02	V
Input Voltage	V_{IN}				18	V
Maximum Output Current	I_{OUT_max}	$V_{IN} = V_{OUT} + 1V$		250	300	mA
Load Regulation	ΔV_{OUT}	$V_{IN} = V_{OUT} + 1V$, $1mA \leq I_{OUT} \leq 60mA$		20	40	mV
Dropout Voltage (Note 3)	V_{DIF}	$I_{OUT} = 40mA$		80		mV
Supply Current	I_{SS}	$V_{IN} = V_{OUT} + 1V$		3	5	μA
Line Regulations	$\frac{\Delta V_{OUT}}{\Delta V_{IN}} \times V_{OUT}$	$I_{OUT} = 40mA$ $V_{OUT} + 1V \leq V_{IN} \leq 18V$		0.1	0.2	%/V
$\Delta V_{OUT} / \Delta T_a$	Temperature Coefficient	$V_{IN} = V_{OUT} + 1V$, $I_{OUT} = 40mA$ $-40^\circ C < T_a < 85^\circ C$		± 0.7		mV/ $^\circ C$

ME6209A33

($V_{IN} = V_{OUT} + 1.0V$, $C_{IN} = C_L = 10\mu F$, $T_a = 25^\circ C$, unless otherwise noted)

Parameter	Symbol	Conditions	Min.	Typ.	Max.	Units
Output Voltage	$V_{OUT}(E)$ (Note 2)	$I_{OUT} = 40mA$, $V_{IN} = V_{OUT} + 1V$	X 0.98	$V_{OUT}(T)$ (Note 1)	X 1.02	V
Input Voltage	V_{IN}				18	V
Maximum Output Current	I_{OUT_max}	$V_{IN} = V_{OUT} + 1V$		250	300	mA
Load Regulation	ΔV_{OUT}	$V_{IN} = V_{OUT} + 1V$, $1mA \leq I_{OUT} \leq 60mA$		15	40	mV
Dropout Voltage (Note 3)	V_{DIF}	$I_{OUT} = 40mA$		80		mV
Supply Current	I_{SS}	$V_{IN} = V_{OUT} + 1V$		3	5	μA
Line Regulations	$\frac{\Delta V_{OUT}}{\Delta V_{IN}} \times V_{OUT}$	$I_{OUT} = 40mA$ $V_{OUT} + 1V \leq V_{IN} \leq 18V$		0.05	0.2	%/V
$\Delta V_{OUT}/\Delta T_a$	Temperature Coefficient	$V_{IN} = V_{OUT} + 1V$, $I_{OUT} = 40mA$ $-40^\circ C < T_a < 85^\circ C$		± 0.7		mV/ $^\circ C$

ME6209A36

($V_{IN} = V_{OUT} + 1.0V$, $C_{IN} = C_L = 10\mu F$, $T_a = 25^\circ C$, unless otherwise noted)

Parameter	Symbol	Conditions	Min.	Typ.	Max.	Units
Output Voltage	$V_{OUT}(E)$ (Note 2)	$I_{OUT} = 40mA$, $V_{IN} = V_{OUT} + 1V$	X 0.98	$V_{OUT}(T)$ (Note 1)	X 1.02	V
Input Voltage	V_{IN}				18	V
Maximum Output Current	I_{OUT_max}	$V_{IN} = V_{OUT} + 1V$		250	300	mA
Load Regulation	ΔV_{OUT}	$V_{IN} = V_{OUT} + 1V$, $1mA \leq I_{OUT} \leq 60mA$		15	40	mV
Dropout Voltage (Note 3)	V_{DIF}	$I_{OUT} = 40mA$		80		mV
Supply Current	I_{SS}	$V_{IN} = V_{OUT} + 1V$		3	5	μA
Line Regulations	$\frac{\Delta V_{OUT}}{\Delta V_{IN}} \times V_{OUT}$	$I_{OUT} = 40mA$ $V_{OUT} + 1V \leq V_{IN} \leq 18V$		0.05	0.2	%/V
$\Delta V_{OUT}/\Delta T_a$	Temperature Coefficient	$V_{IN} = V_{OUT} + 1V$, $I_{OUT} = 40mA$ $-40^\circ C < T_a < 85^\circ C$		± 0.7		mV/ $^\circ C$

ME6209A40

($V_{IN} = V_{OUT} + 1.0V$, $C_{IN} = C_L = 10\mu F$, $T_a = 25^\circ C$, unless otherwise noted)

Parameter	Symbol	Conditions	Min.	Typ.	Max.	Units
Output Voltage	$V_{OUT}(E)$ (Note 2)	$I_{OUT} = 40mA$, $V_{IN} = V_{OUT} + 1V$	X 0.98	$V_{OUT}(T)$ (Note 1)	X 1.02	V
Input Voltage	V_{IN}				18	V
Maximum Output Current	I_{OUT_max}	$V_{IN} = V_{OUT} + 1V$		250	300	mA
Load Regulation	ΔV_{OUT}	$V_{IN} = V_{OUT} + 1V$, $1mA \leq I_{OUT} \leq 60mA$		15	40	mV
Dropout Voltage (Note 3)	V_{DIF}	$I_{OUT} = 40mA$		70		mV
Supply Current	I_{SS}	$V_{IN} = V_{OUT} + 1V$		3	5	μA
Line Regulations	$\frac{\Delta V_{OUT}}{\Delta V_{IN}} \times V_{OUT}$	$I_{OUT} = 40mA$ $V_{OUT} + 1V \leq V_{IN} \leq 18V$		0.1	0.2	%/V
$\Delta V_{OUT} / \Delta T_a$	Temperature Coefficient	$V_{IN} = V_{OUT} + 1V$, $I_{OUT} = 40mA$ $-40^\circ C < T_a < 85^\circ C$		± 0.7		mV/ $^\circ C$

ME6209A45

($V_{IN} = V_{OUT} + 1.0V$, $C_{IN} = C_L = 10\mu F$, $T_a = 25^\circ C$, unless otherwise noted)

Parameter	Symbol	Conditions	Min.	Typ.	Max.	Units
Output Voltage	$V_{OUT}(E)$ (Note 2)	$I_{OUT} = 40mA$, $V_{IN} = V_{OUT} + 1V$	X 0.98	$V_{OUT}(T)$ (Note 1)	X 1.02	V
Input Voltage	V_{IN}				18	V
Maximum Output Current	I_{OUT_max}	$V_{IN} = V_{OUT} + 1V$		250	300	mA
Load Regulation	ΔV_{OUT}	$V_{IN} = V_{OUT} + 1V$, $1mA \leq I_{OUT} \leq 60mA$		15	40	mV
Dropout Voltage (Note 3)	V_{DIF}	$I_{OUT} = 40mA$		73		mV
Supply Current	I_{SS}	$V_{IN} = V_{OUT} + 1V$		3	5	μA
Line Regulations	$\frac{\Delta V_{OUT}}{\Delta V_{IN}} \times V_{OUT}$	$I_{OUT} = 40mA$ $V_{OUT} + 1V \leq V_{IN} \leq 18V$		0.05	0.2	%/V
$\Delta V_{OUT} / \Delta T_a$	Temperature Coefficient	$V_{IN} = V_{OUT} + 1V$, $I_{OUT} = 40mA$ $-40^\circ C < T_a < 85^\circ C$		± 0.7		mV/ $^\circ C$

ME6209A50

($V_{IN} = V_{OUT} + 1.0V$, $C_{IN} = C_L = 10\mu F$, $T_a = 25^\circ C$, unless otherwise noted)

Parameter	Symbol	Conditions	Min.	Typ.	Max.	Units
Output Voltage	$V_{OUT(E)}$ (Note 2)	$I_{OUT} = 40mA$, $V_{IN} = V_{OUT} + 1V$	X 0.98	$V_{OUT(T)}$ (Note 1)	X 1.02	V
Input Voltage	V_{IN}				18	V
Maximum Output Current	I_{OUT_max}	$V_{IN} = V_{OUT} + 1V$		250	300	mA
Load Regulation	ΔV_{OUT}	$V_{IN} = V_{OUT} + 1V$, $1mA \leq I_{OUT} \leq 60mA$		15	40	mV
Dropout Voltage (Note 3)	V_{DIF}	$I_{OUT} = 40mA$		75		mV
Supply Current	I_{SS}	$V_{IN} = V_{OUT} + 1V$		3	5	μA
Line Regulations	$\frac{\Delta V_{OUT}}{\Delta V_{IN} \times V_{OUT}}$	$I_{OUT} = 40mA$ $V_{OUT} + 1V \leq V_{IN} \leq 18V$		0.05	0.2	%/V
$\Delta V_{OUT} / \Delta T_a$	Temperature Coefficient	$V_{IN} = V_{OUT} + 1V$, $I_{OUT} = 40mA$ $-40^\circ C < T_a < 85^\circ C$		± 0.7		mV/ $^\circ C$

Note :

- $V_{OUT(T)}$: Specified Output Voltage
- $V_{OUT(E)}$: Effective Output Voltage (ie. The output voltage when " $V_{OUT(T)} + 1.0V$ " is provided at the Vin pin while maintaining a certain I_{OUT} value.)
- V_{DIF} : $V_{IN1} - V_{OUT(E)}$
 V_{IN1} : The input voltage when $V_{OUT(E)}$ appears as input voltage is gradually decreased.
 $V_{OUT(E)}$ = A voltage equal to 98% of the output voltage whenever an amply stabilized I_{OUT} and $\{V_{OUT(T)} + 1.0V\}$ is input.

Precautions

- During the test, if AC/DC power supply and the ceramic chip capacitors collocation are used, there may be serious voltage spike phenomenon instantaneously. When the power supply access to 16V, the voltage is rushed to about 30V instantaneously. Because of exceeding the limit voltage of chip, the chip is damaged. If you string a small resistance of 1 ohm in the input end during the test, the peak phenomenon can be avoided.
- In the test, there is serious burr phenomenon only when the AC/DC power is used with ceramic chip capacitors. But electrolytic capacitors and tantalum capacitance won't appear above phenomenon. Please be sure to pay attention to this point when you use AC/DC power.
- In normal use, when any type of capacitor is used with battery or the supply of fire power, the above phenomenon doesn't occur.

Type Characteristics(ME6209A40)

- (1) Output Voltage VS. Output Current ($T_a = 25^\circ\text{C}$) (2) Output Voltage VS. Input Voltage

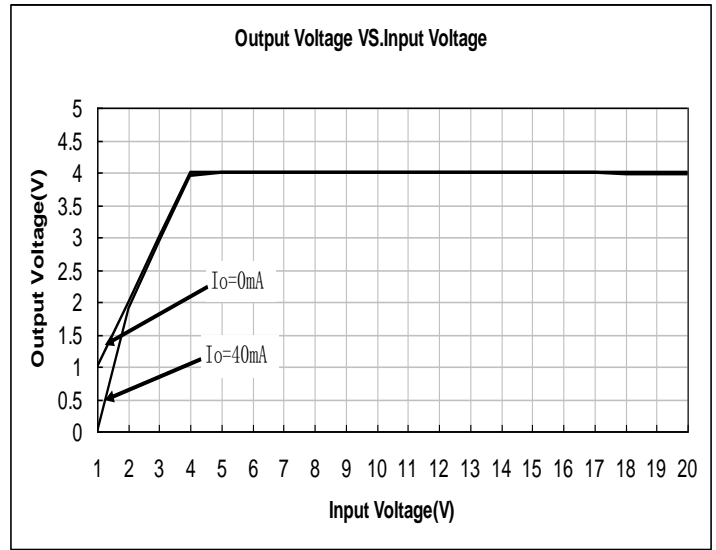
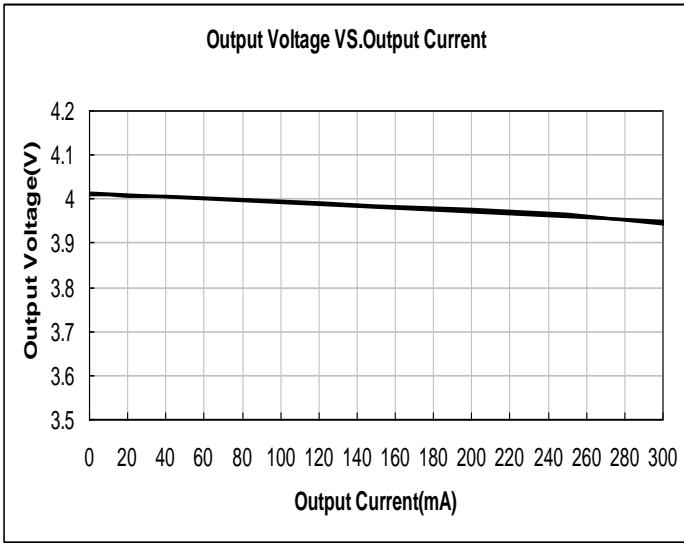

- (3) Quiescent Current VS. Input Voltage

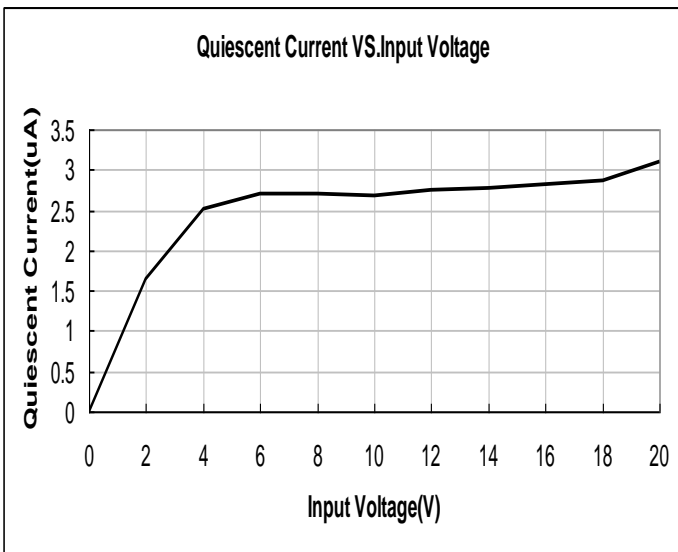

- (4) Dropout Voltage VS. Output Current

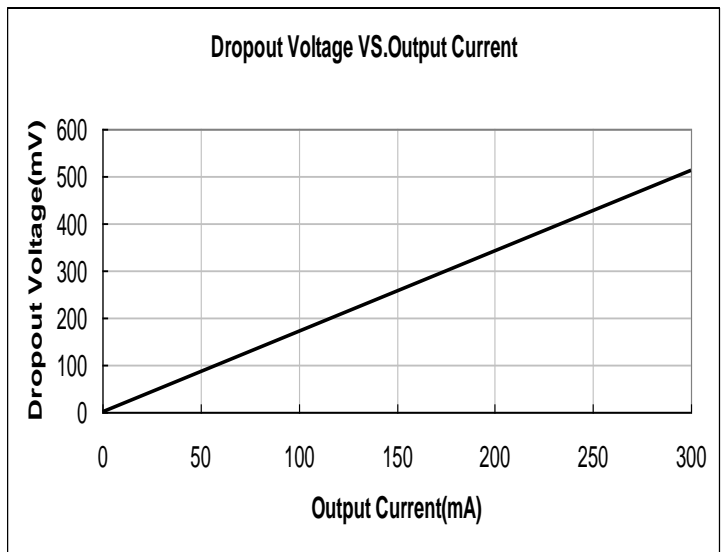

- (5) Output Voltage VS. Temperature (**ME6209A33PG**)

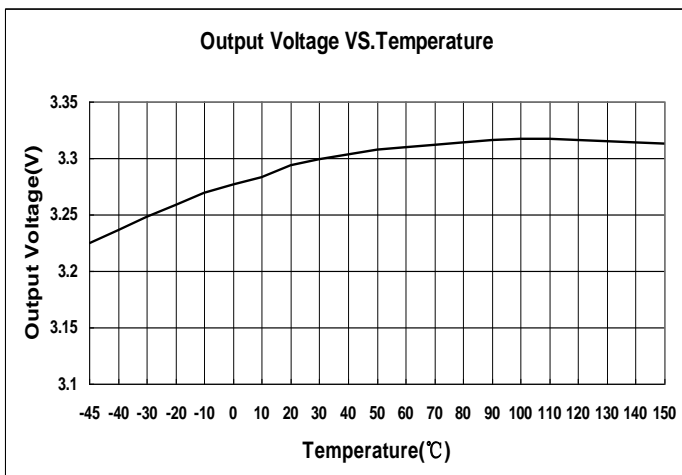

Packaging Information

● Packaging Type: SOT23-3

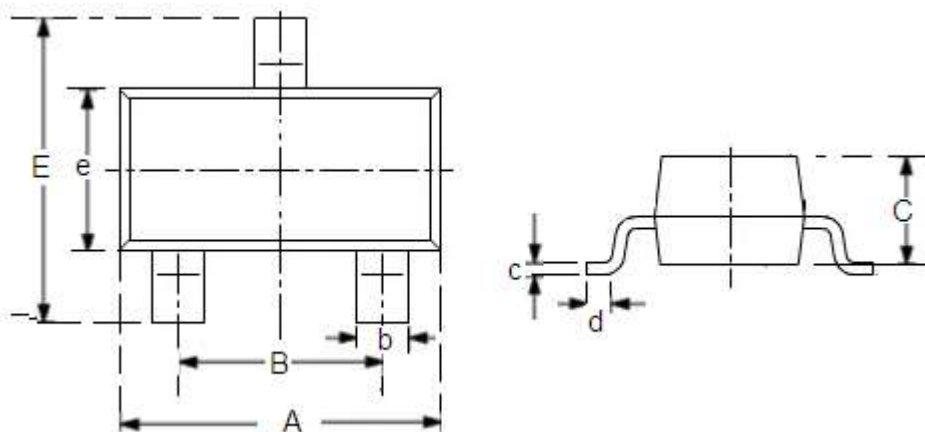

DIM	Millimeters		Inches	
	Min	Max	Min	Max
A	2.7	3.1	0.1063	0.122
B	1.7	2.1	0.0669	0.0827
b	0.35	0.5	0.0138	0.0197
C	1.0	1.2	0.0394	0.0472
c	0.1	0.25	0.0039	0.0098
d	0.2	-	0.0079	-
E	2.6	3.0	0.1023	0.1181
e	1.5	1.8	0.059	0.0708

● Packaging Type: SOT89-3

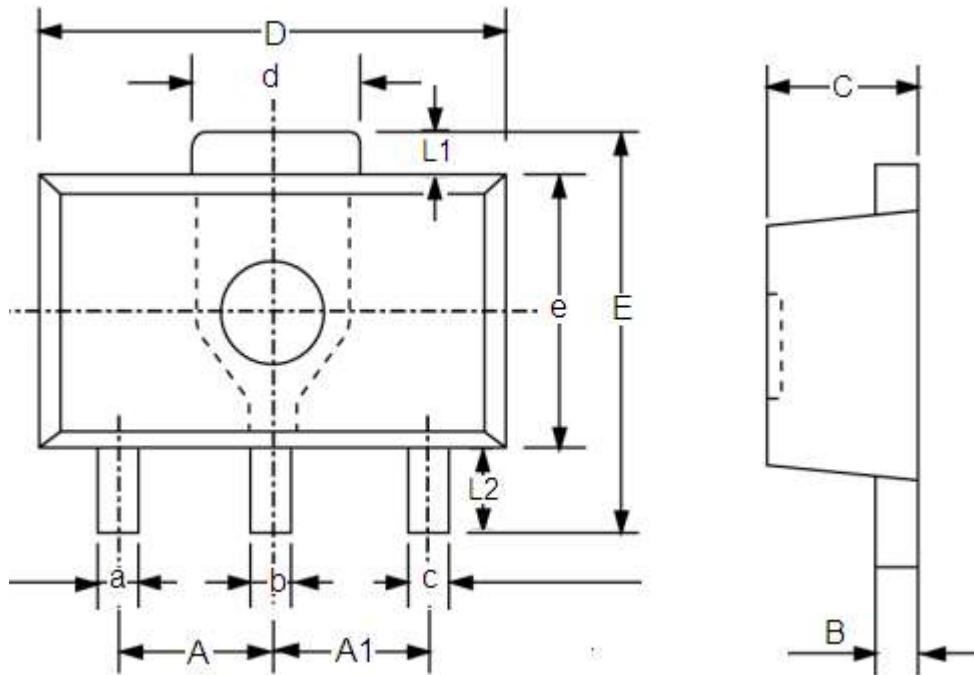

DIM	Millimeters		Inches	
	Min	Max	Min	Max
A	1.4	1.6	0.0551	0.0630
A1	1.4	1.6	0.0551	0.0630
a	0.36	0.48	0.0142	0.0189
b	0.41	0.53	0.0161	0.0209
c	0.36	0.48	0.0142	0.0189
d	1.4	1.75	0.0551	0.0689
B	0.38	0.43	0.015	0.0169
C	1.4	1.6	0.0551	0.0630
D	4.4	4.6	0.1732	0.181
E	-	4.25	-	0.1673
e	2.4	2.6	0.0945	0.1023
L1	0.4	-	0.0157	-
L2	0.8	-	0.0315	-

● Packaging Type:TO-92

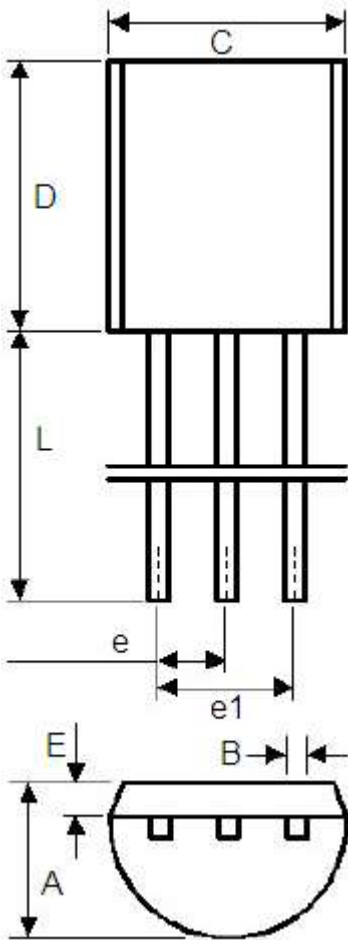

	Min	Max	Min	Max
A	3.4	3.8	0.13386	0.1496
B	0.3	0.5	0.0118	0.0197
C	4.4	4.8	0.1732	0.189
D	4.4	4.8	0.1732	0.189
E	0.9	1.5	0.0354	0.059
e	1.17	1.37	0.046	0.0539
e1	2.39	2.69	0.094	0.1059
L	12	16	0.4724	0.6299

- The information described herein is subject to change without notice.
- Nanjing Micro One Electronics Inc is not responsible for any problems caused by circuits or diagrams described herein whose related industrial properties, patents, or other rights belong to third parties. The application circuit examples explain typical applications of the products, and do not guarantee the success of any specific mass-production design.
- Use of the information described herein for other purposes and/or reproduction or copying without the express permission of Nanjing Micro One Electronics Inc is strictly prohibited.
- The products described herein cannot be used as part of any device or equipment affecting the human body, such as exercise equipment, medical equipment, security systems, gas equipment, or any apparatus installed in airplanes and other vehicles, without prior written permission of Nanjing Micro One Electronics Inc.
- Although Nanjing Micro One Electronics Inc exerts the greatest possible effort to ensure high quality and reliability, the failure or malfunction of semiconductor products may occur. The user of these products should therefore give thorough consideration to safety design, including redundancy, fire-prevention measures, and malfunction prevention, to prevent any accidents, fires, or community damage that may ensue.

X-ON Electronics

Largest Supplier of Electrical and Electronic Components

Click to view similar products for [LDO Voltage Regulators](#) category:

Click to view products by [Micro One](#) manufacturer:

Other Similar products are found below :

[AP7363-SP-13](#) [L79M05TL-E](#) [AP7362-HA-7](#) [PT7M8202B12TA5EX](#) [TCR3DF185,LM\(CT](#) [TCR3DF45,LM\(CT](#) [TLE4473G V52](#) [059985X](#)
[NCP4687DH15T1G](#) [701326R](#) [NCV8170AXV250T2G](#) [AP7315-25W5-7](#) [AP2111H-1.2TRG1](#) [ZLDO1117QK50TC](#) [AZ1117ID-ADJTRG1](#)
[TCR3DG12,LF](#) [MIC5514-3.3YMT-T5](#) [SCD7912BTG](#) [NCP154MX180270TAG](#) [SCD33269T-5.0G](#) [NCV8170BXV330T2G](#)
[NCV8170BMX330TCG](#) [NCV8170AMX120TCG](#) [NCP706ABMX300TAG](#) [NCP153MX330180TCG](#) [NCP114BMX075TCG](#) [MC33269T-3.5G](#)
[CAT6243-ADJCMT5T](#) [TCR3DG33,LF](#) [TCR4DG35,LF](#) [TAR5S15U\(TE85L,F\)](#) [TAR5S18U\(TE85L,F\)](#) [TCR3UG19A,LF](#) [TCR4DG105,LF](#)
[MPQ2013AGG-5-P](#) [NCV8170AMX360TCG](#) [TLE4268GSXUMA2](#) [NCP715SQ15T2G](#) [MIC5317-3.0YD5-T5](#) [NCV563SQ18T1G](#)
[NCP715MX30TBG](#) [NCV8702MX25TCG](#) [NCV8170BXV120T2G](#) [MIC5317-1.2YD5-T5](#) [NCV8170AMX150TCG](#) [NCV8170BMX150TCG](#)
[AP2213D-3.3TRG1](#) [NCV8170BMX120TCG](#) [NCV8170BMX310TCG](#) [NCV8170BMX360TCG](#)