

500mA, Low Quiescent, Low Dropout LDO Linear Regulators

ME6210 Series

General Description

ME6210 series are low quiescent, low-dropout linear voltage regulators. ME6210 series are based on the CMOS process and allow high voltage input. The allow operation voltage as high as 18V. ME6210 series have short circuit protection function.

Features

- High output accuracy: $\pm 2\%$
- Input voltage: 2V to 18V
- Output voltage: 1.5V ~ 5.0V
- Ultra-low quiescent current (Typ. = 1.5 μ A)
- Output Current: $I_{out} = 500\text{mA}$
(When $V_{in} = 4\text{V}$ and $V_{out} = 3\text{V}$)
- Low dropout voltage: 11mV @ $I_{out} = 10\text{mA}$ (Typ. $V_{out} = 3.0\text{V}$)
- Input good stability: Typ. 0.03% / V
- Short-circuit Current: Typ. 50mA
- Ceramic capacitor can be used
- Package: SOT89-3, SOT23-3, TO-92.

Selection Guide

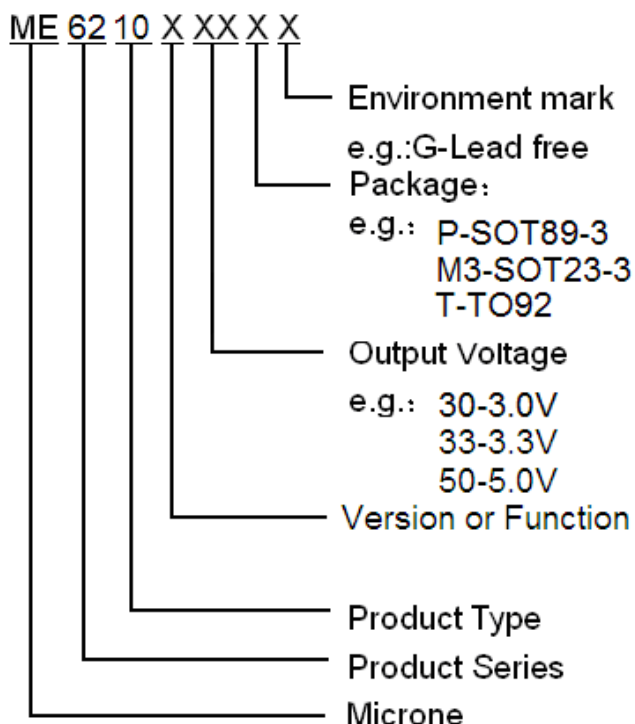

Typical Application

- Power source for home electric/electronic appliances
- Power source for battery-powered devices
- Power source for personal communication devices

Typical Application Circuit

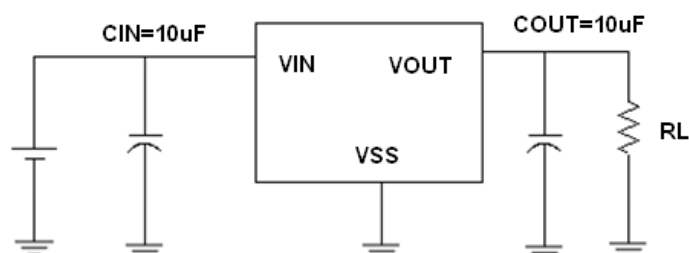

Pin Configuration

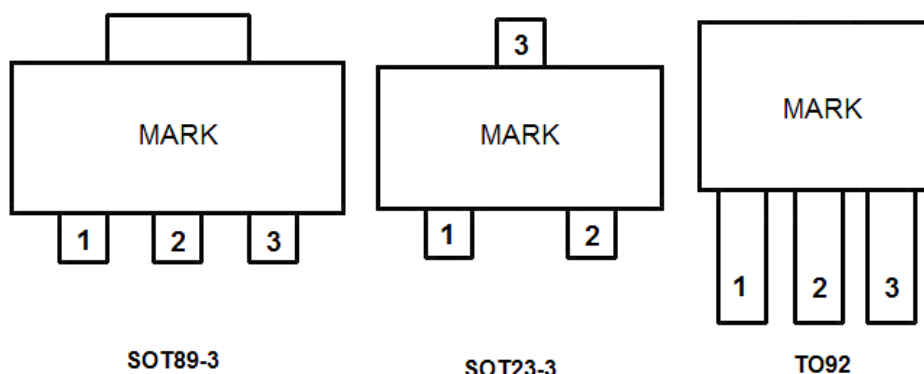

Pin Assignment

ME6210AXX

Pin Number		Pin Name	Functions
SOT89-3 / TO92	SOT23-3		
1	1	V_{SS}	Ground
2	3	V_{IN}	Power Input
3	2	V_{OUT}	Output

Absolute Maximum Ratings

Parameter	Symbol	Ratings	Units
Input Voltage	V_{IN}	18	V
Output Current	I_{OUT}	700	mA
Output Voltage	V_{OUT}	$V_{SS}-0.3 \sim V_{IN} + 0.3$	V
Power Dissipation	SOT89-3	P_D	500
	TO92		500
	SOT23-3		300
Operating Temperature Range	T_{OPR}	$-25 \sim +85$	$^{\circ}C$
Storage Temperature Range	T_{STG}	$-40 \sim +125$	$^{\circ}C$
Lead Temperature		$260^{\circ}C, 10sec$	

Block Diagram

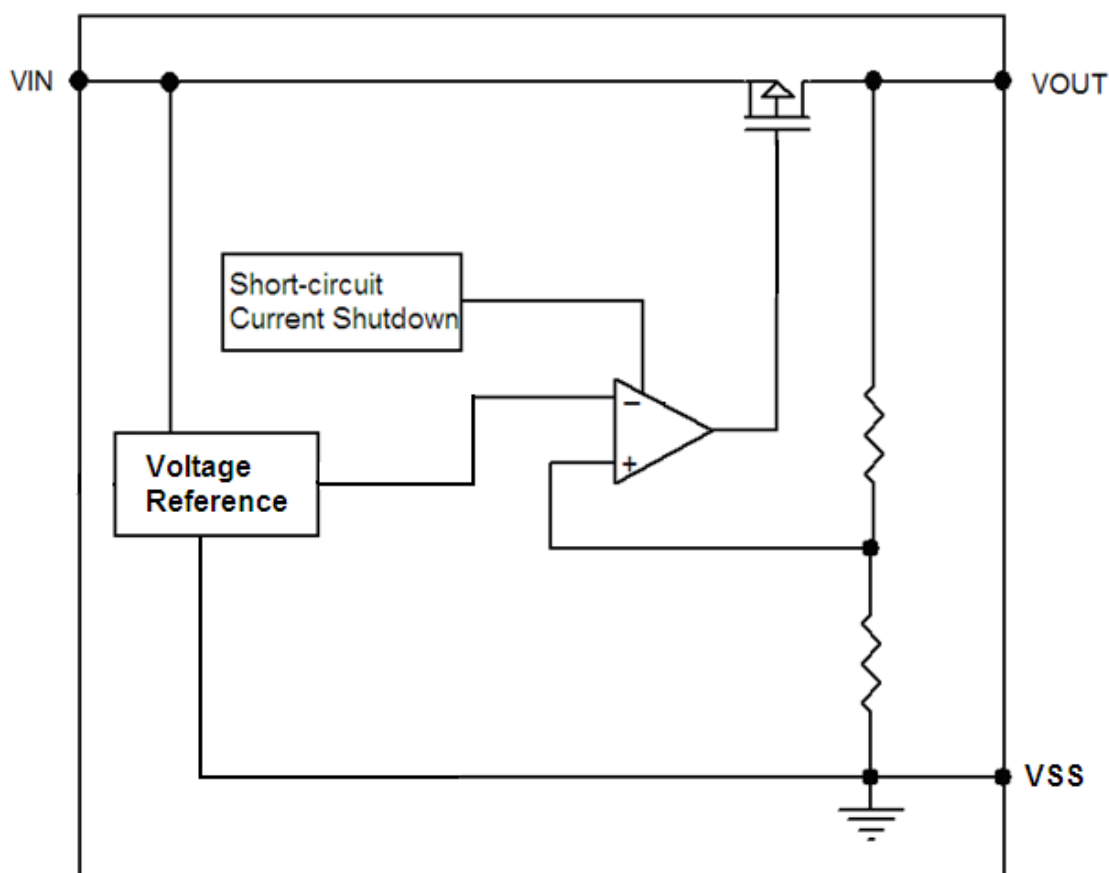

Electrical Characteristics

ME6210A30

($V_{IN} = V_{OUT} + 1.0V$, $C_{IN} = C_{OUT} = 10\mu F$, $T_a = 25^\circ C$, unless otherwise noted)

Parameter	Symbol	Conditions	Min.	Typ.	Max.	Units
Output Voltage	$V_{OUT(E)}$ (Note 2)	$I_{OUT} = 40mA$, $V_{IN} = V_{out} + 1V$	X 0.98	$V_{OUT(T)}$ (Note 1)	X 1.02	V
Input Voltage	V_{IN}				18	V
Maximum Output Current	I_{OUT_max}	$V_{IN} = V_{out} + 1V$	500	500		mA
Load Regulation	ΔV_{OUT}	$V_{IN} = V_{out} + 1V$, $1mA \leq I_{OUT} \leq 200mA$		12	30	mV
Dropout Voltage (Note 3)	V_{DIF1}	$I_{OUT} = 10mA$		11	14	mV
	V_{DIF2}	$I_{OUT} = 100mA$		110	140	mV
	V_{DIF3}	$I_{OUT} = 200mA$		220	280	mV

Supply Current	I_{SS}	$V_{IN}=V_{out}+1V$		1.5	2.5	μA
Line Regulations	$\frac{\Delta V_{OUT}}{\Delta V_{IN}} \times V_{OUT}$	$I_{OUT}=10mA$ $V_{out}+1V \leq V_{IN} \leq 18V$		0.03	0.1	%/V
Temperature coefficient	$\frac{\Delta V_{OUT}}{\Delta Ta} \times V_{OUT}$	$V_{IN}=V_{out}+1V, I_{OUT}=10mA$ $-40^{\circ}C \leq Ta \leq 125^{\circ}C$		± 60	± 100	Ppm/ $^{\circ}C$
Short-circuit Current	I_{short}	$V_{IN}=V_{out}+1V$		50	70	mA

ME6210A33

($V_{IN}=V_{OUT}+1.0V$, $C_{IN}=C_{OUT}=10\mu F$, $Ta=25^{\circ}C$, unless otherwise noted)

Parameter	Symbol	Conditions	Min.	Typ.	Max.	Units
Output Voltage	$V_{OUT}(E)$ (Note 2)	$I_{OUT}=40mA$, $V_{IN}=V_{out}+1V$	X 0.98	$V_{OUT}(T)$ (Note 1)	X 1.02	V
Input Voltage	V_{IN}				18	V
Maximum Output Current	I_{OUT_max}	$V_{IN}=V_{out}+1V$	500	500		mA
Load Regulation	ΔV_{OUT}	$V_{IN}=V_{out}+1V$, $1mA \leq I_{OUT} \leq 200mA$		12	30	mV
Dropout Voltage (Note 3)	V_{DIF1}	$I_{OUT}=10mA$		10	13	mV
	V_{DIF2}	$I_{OUT}=100mA$		100	130	mV
	V_{DIF3}	$I_{OUT}=200mA$		200	260	mV
Supply Current	I_{SS}	$V_{IN}=V_{out}+1V$		1.6	2.5	μA
Line Regulations	$\frac{\Delta V_{OUT}}{\Delta V_{IN}} \times V_{OUT}$	$I_{OUT}=10mA$ $V_{out}+1V \leq V_{IN} \leq 18V$		0.03	0.1	%/V
Temperature coefficient	$\frac{\Delta V_{OUT}}{\Delta Ta} \times V_{OUT}$	$V_{IN}=V_{out}+1V, I_{OUT}=10mA$ $-40^{\circ}C \leq Ta \leq 125^{\circ}C$		± 60	± 100	Ppm/ $^{\circ}C$
Short-circuit Current	I_{short}	$V_{IN}=V_{out}+1V$		50	70	mA

ME6210A50

($V_{IN}=V_{OUT}+1.0V$, $C_{IN}=C_{OUT}=10\mu F$, $Ta=25^{\circ}C$, unless otherwise noted)

Parameter	Symbol	Conditions	Min.	Typ.	Max.	Units
Output Voltage	$V_{OUT}(E)$ (Note 2)	$I_{OUT}=40mA$, $V_{IN}=V_{out}+1V$	X 0.98	$V_{OUT}(T)$ (Note 1)	X 1.02	V
Input Voltage	V_{IN}				18	V
Maximum Output Current	I_{OUT_max}	$V_{IN}=V_{out}+1V$	500	500		mA
Load Regulation	ΔV_{OUT}	$V_{IN}=V_{out}+1V$, $1mA \leq I_{OUT} \leq 200mA$		10	30	mV

Dropout Voltage (Note 3)	V_{DIF1}	$I_{OUT} = 10mA$		8	11	mV
	V_{DIF2}	$I_{OUT} = 100mA$		80	110	mV
	V_{DIF3}	$I_{OUT} = 200mA$		160	220	mV
Supply Current	I_{SS}	$V_{IN} = V_{out} + 1V$		1.7	2.5	μA
Line Regulations	$\frac{\Delta V_{OUT}}{\Delta V_{IN} \times V_{OUT}}$	$I_{OUT} = 10mA$ $V_{out} + 1V \leq V_{IN} \leq 18V$		0.03	0.1	%/V
Temperature coefficient	$\frac{\Delta V_{OUT}}{\Delta T_a \times V_{OUT}}$	$V_{IN} = V_{out} + 1V, I_{OUT} = 10mA$ $-40^\circ C \leq T_a \leq 125^\circ C$		± 60	± 100	Ppm/ $^\circ C$
Short-circuit Current	I_{short}	$V_{IN} = V_{out} + 1V$		50	70	mA

Note :

- $V_{OUT}(T)$: Specified Output Voltage
- $V_{OUT}(E)$: Effective Output Voltage (ie. The output voltage when " $V_{OUT}(T) + 1.0V$ " is provided at the Vin pin while maintaining a certain Iout value.)
- V_{DIF} : $V_{IN1} - V_{OUT}(E)'$
 V_{IN1} : The input voltage when $V_{OUT}(E)'$ appears as input voltage is gradually decreased.
 $V_{OUT}(E)'$ = A voltage equal to 98% of the output voltage whenever an amply stabilized Iout and $\{V_{OUT}(T) + 1.0V\}$ is input.

Precautions

- During the test, if AC/DC power supply and the ceramic chip capacitors collocation is used, there may be serious voltage spike phenomenon instantaneously. When the power supply access to 15V, the voltage is rushed to about 30V instantaneously. Because of exceeding the limit voltage of chip, the chip is damaged. If you string a small resistance of 1 ohm in the input end during the test, the peak phenomenon can be avoided.
- In the test, there is serious burr phenomenon only when the AC/DC power is used with ceramic chip capacitors. But electrolytic capacitors and tantalum capacitance won't appear above phenomenon. Please be sure to pay attention to this point when you use AC/DC power.
- In normal use, when any type of capacitor is used with battery or the supply of fire power, the above phenomenon doesn't occur.

Type Characteristics

(1) Output Voltage VS. Output Current

($T_a = 25\text{ }^\circ\text{C}$, $V_{IN}=4\text{V}$) ME6210A30

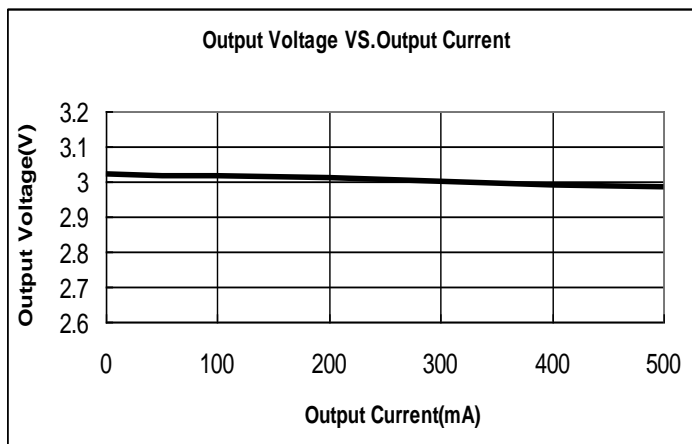

(2) Output Voltage VS. Input Voltage

($T_a = 25\text{ }^\circ\text{C}$, $I_{out}=10\text{mA}$) ME6210A30

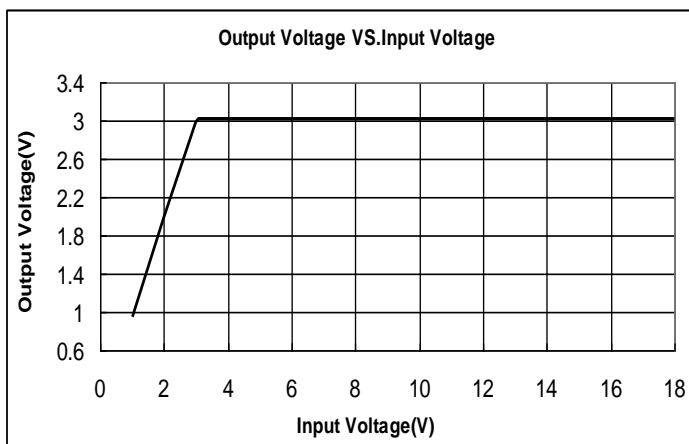

(3) Dropout Voltage VS. Output Current

($T_a = 25\text{ }^\circ\text{C}$) ME6210A30

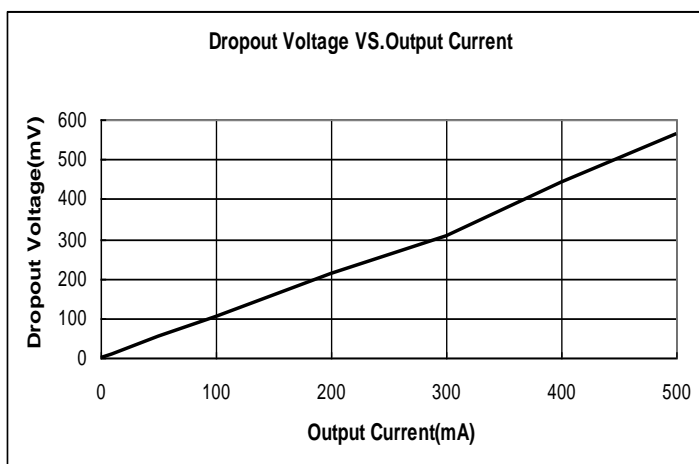

(4) Supply Current VS. Input Voltage

($T_a = 25\text{ }^\circ\text{C}$) ME6210A30

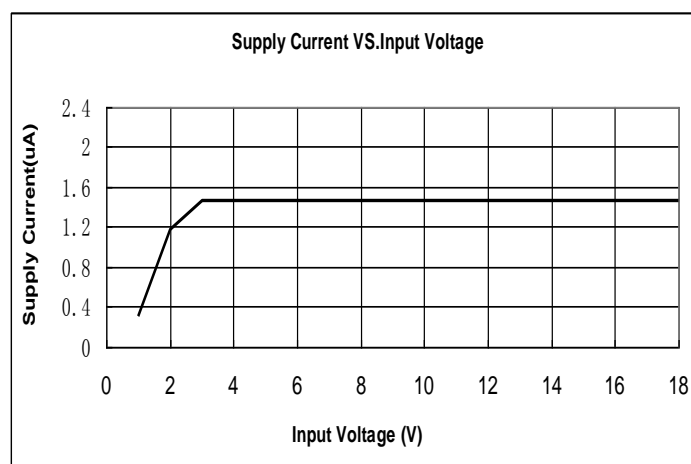

(5) Output Voltage VS. Temperature ($V_{IN}=4\text{V}$, $I_{out}=10\text{mA}$) ME6210A30

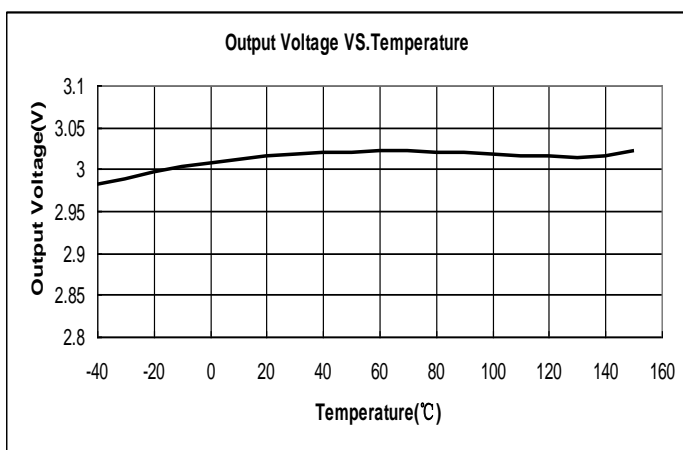

Packaging Information

● SOT89-3

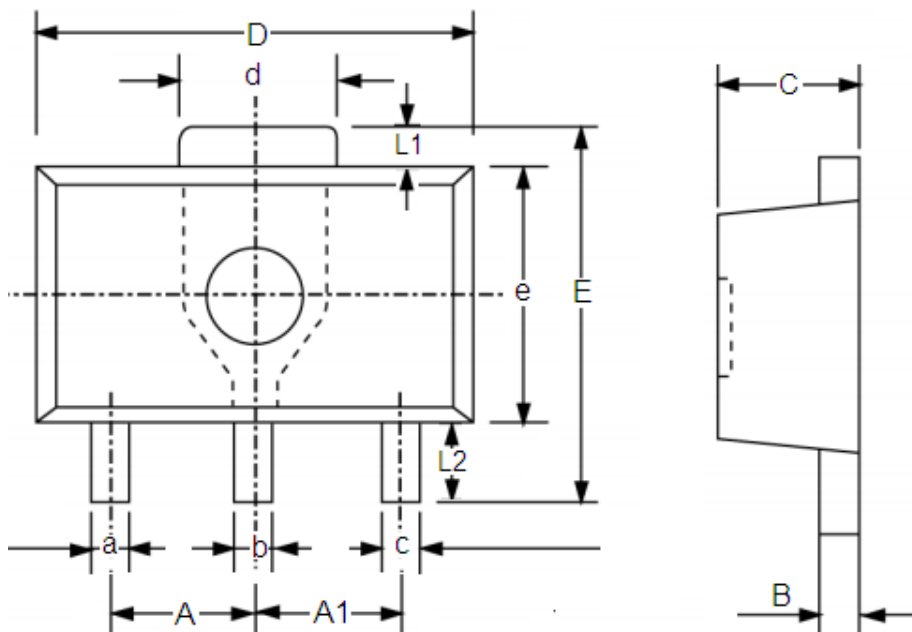

DIM	Millimeters		Inches	
	Min	Max	Min	Max
A	1.4	1.6	0.0551	0.0630
A1	1.4	1.6	0.0551	0.0630
a	0.36	0.48	0.0142	0.0189
b	0.41	0.53	0.0161	0.0209
c	0.36	0.48	0.0142	0.0189
d	1.4	1.75	0.0551	0.0689
B	0.38	0.43	0.015	0.0169
C	1.4	1.6	0.0551	0.0630
D	4.4	4.6	0.1732	0.181
E	-	4.25	-	0.1673
e	2.4	2.6	0.0945	0.1023
L1	0.4	-	0.0157	-
L2	0.8	-	0.0315	-

● SOT23-3

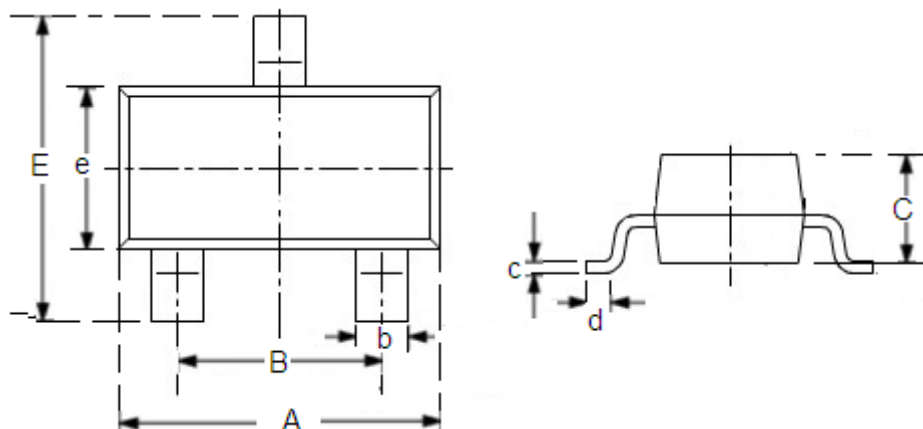

DIM	Millimeters		Inches	
	Min	Max	Min	Max
A	2.7	3.1	0.1063	0.122
B	1.7	2.1	0.0669	0.0827
b	0.35	0.5	0.0138	0.0197
C	1.0	1.2	0.0394	0.0472
c	0.1	0.25	0.0039	0.0098
d	0.2	-	0.0079	-
E	2.6	3.0	0.1023	0.1181
e	1.5	1.8	0.059	0.0708

● TO-92

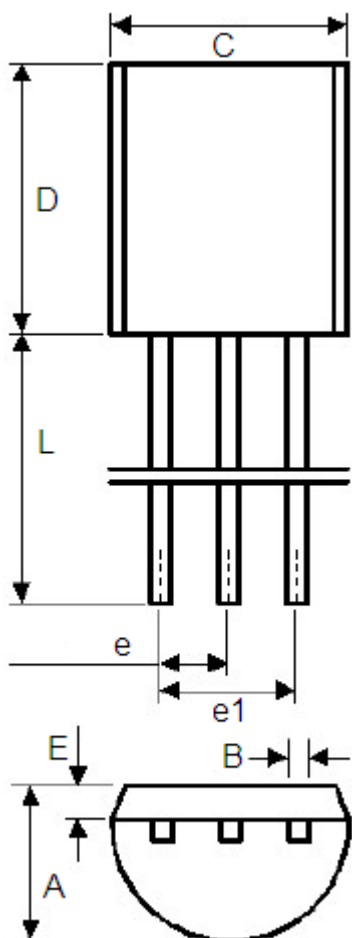

	Min	Max	Min	Max
A	3.4	3.8	0.13386	0.1496
B	0.3	0.5	0.0118	0.0197
C	4.4	4.8	0.1732	0.189
D	4.4	4.8	0.1732	0.189
E	0.9	1.5	0.0354	0.059
e	1.17	1.37	0.046	0.0539
e1	2.39	2.69	0.094	0.1059
L	12	16	0.4724	0.6299

- The information described herein is subject to change without notice.
- Nanjing Micro One Electronics Inc is not responsible for any problems caused by circuits or diagrams described herein whose related industrial properties, patents, or other rights belong to third parties. The application circuit examples explain typical applications of the products, and do not guarantee the success of any specific mass-production design.
- Use of the information described herein for other purposes and/or reproduction or copying without the express permission of Nanjing Micro One Electronics Inc is strictly prohibited.
- The products described herein cannot be used as part of any device or equipment affecting the human body, such as exercise equipment, medical equipment, security systems, gas equipment, or any apparatus installed in airplanes and other vehicles, without prior written permission of Nanjing Micro One Electronics Inc.
- Although Nanjing Micro One Electronics Inc exerts the greatest possible effort to ensure high quality and reliability, the failure or malfunction of semiconductor products may occur. The user of these products should therefore give thorough consideration to safety design, including redundancy, fire-prevention measures, and malfunction prevention, to prevent any accidents, fires, or community damage that may ensue.

X-ON Electronics

Largest Supplier of Electrical and Electronic Components

Click to view similar products for [LDO Voltage Regulators](#) category:

Click to view products by [Micro One](#) manufacturer:

Other Similar products are found below :

[AP7363-SP-13](#) [L79M05TL-E](#) [AP7362-HA-7](#) [PT7M8202B12TA5EX](#) [TCR3DF185,LM\(CT](#) [TCR3DF45,LM\(CT](#) [TLE4473G V52](#) [059985X](#)
[NCP4687DH15T1G](#) [701326R](#) [NCV8170AXV250T2G](#) [AP7315-25W5-7](#) [AP2111H-1.2TRG1](#) [ZLDO1117QK50TC](#) [AZ1117ID-ADJTRG1](#)
[TCR3DG12,LF](#) [MIC5514-3.3YMT-T5](#) [SCD7912BTG](#) [NCP154MX180270TAG](#) [SCD33269T-5.0G](#) [NCV8170BXV330T2G](#)
[NCV8170BMX330TCG](#) [NCV8170AMX120TCG](#) [NCP706ABMX300TAG](#) [NCP153MX330180TCG](#) [NCP114BMX075TCG](#) [MC33269T-3.5G](#)
[CAT6243-ADJCMT5T](#) [TCR3DG33,LF](#) [TCR4DG35,LF](#) [TAR5S15U\(TE85L,F\)](#) [TAR5S18U\(TE85L,F\)](#) [TCR3UG19A,LF](#) [TCR4DG105,LF](#)
[MPQ2013AGG-5-P](#) [NCV8170AMX360TCG](#) [TLE4268GSXUMA2](#) [NCP715SQ15T2G](#) [MIC5317-3.0YD5-T5](#) [NCV563SQ18T1G](#)
[NCP715MX30TBG](#) [NCV8702MX25TCG](#) [NCV8170BXV120T2G](#) [MIC5317-1.2YD5-T5](#) [NCV8170AMX150TCG](#) [NCV8170BMX150TCG](#)
[AP2213D-3.3TRG1](#) [NCV8170BMX120TCG](#) [NCV8170BMX310TCG](#) [NCV8170BMX360TCG](#)