

Low power consumption, Low dropout voltage,

With CE function ME6215 Series

General Description

ME6215 series are highly precise, low power consumption, high voltage, positive voltage regulators manufactured using CMOS and laser trimming technologies. The series provides large currents with a significantly small dropout voltage. The current limiter's foldback circuit also operates as a short protect for the output current limiter and the output pin. The CE function allows the output of regulator to be turned off, resulting in greatly reduced power consumption. The ME6215 series can operate with up to 18V input.

Features

- Highly Accurate: $\pm 2\%$
- Output voltage range: 1.5V~5.0V
- Low power consumption: 6 μ A(TYP.)
- Large output current: 300mA ($V_{IN}=3.8V, V_{OUT}=2.8V$)
- Input voltage: up to 18V
- Dropout voltage:
0.16V at 100mA and 0.32V at 200mA
- CE Pin Function : Active High
- Short-circuit Current: 25mA(TYP.)
- Excellent Input Stability
- Be available to regulator and reference voltage

Applications

- Battery powered equipment
- Communication tools
- Mobile phones
- Portable games
- Portable AV systems
- Cameras, Video systems
- Reference voltage sources

Packages

- 5-pin SOT23-5

Typical Application

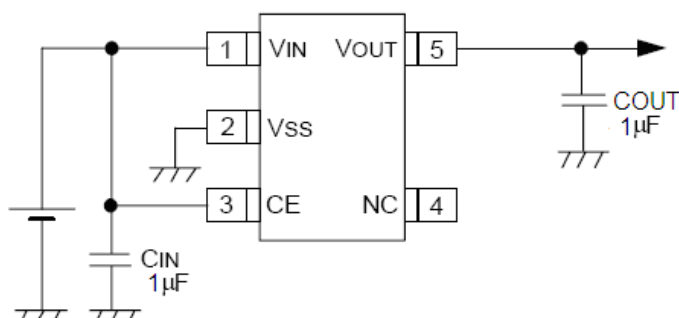

Selection Guide

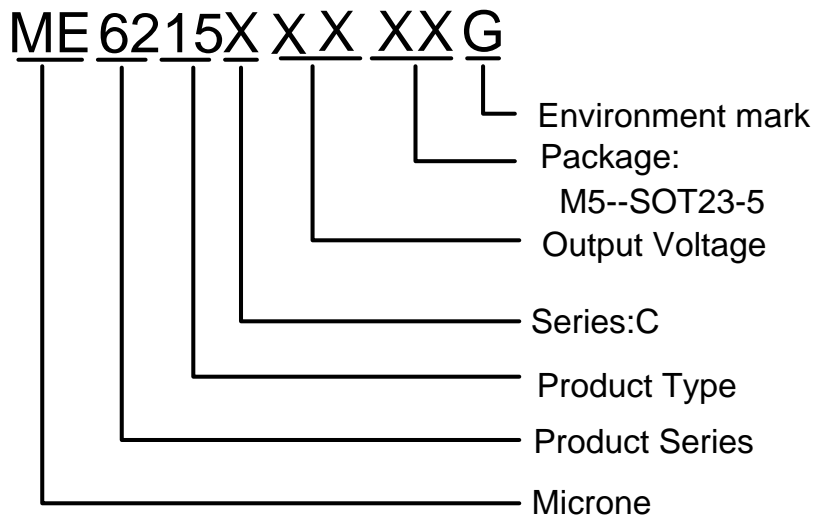

product series	product description
ME6215C28M5G	$V_{OUT} = 2.8V$
ME6215C30M5G	$V_{OUT} = 3.0V$
ME6215C33M5G	$V_{OUT} = 3.3V$

Pin Configuration

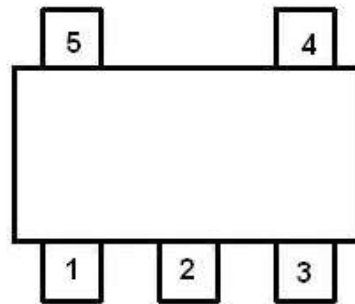

SOT23-5

Pin Assignment

Pin Num	Symbol	Function
SOT23-5		
1	V_{IN}	Power Input
2	V_{SS}	Ground
3	CE	ON / OFF Control
4	NC	No Connect
5	V_{OUT}	Output

Block Diagram

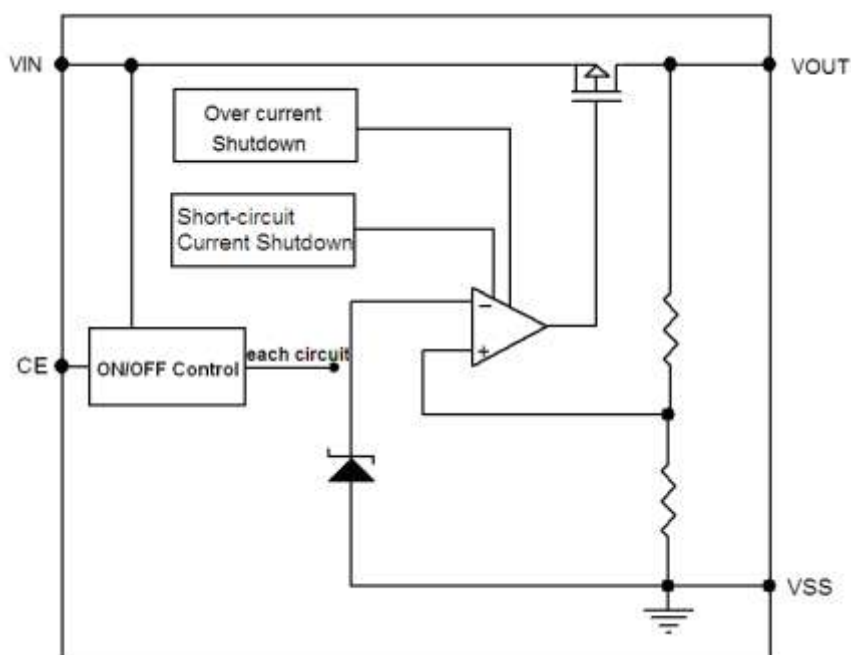

Absolute Maximum Ratings

Parameter	Symbol	Ratings	Units
Input Voltage	V_{IN}	18	V
Output Current	I_{OUT}	580	mA
Output Voltage	V_{OUT}	$V_{SS}-0.3 \sim V_{IN} + 0.3$	V
CE Pin Voltage	V_{CE}	$V_{SS}-0.3 \sim V_{IN} + 0.3$	V
Power Dissipation	SOT23-5 P_D	250	mW
Operating Temperature Range	T_{OPR}	$-40 \sim +125$	$^{\circ}C$
Storage Temperature Range	T_{STG}	$-40 \sim +150$	$^{\circ}C$
Lead Temperature		$260^{\circ}C, 4sec$	

Electrical Characteristics

($V_{IN} = V_{OUT} + 1V$, $V_{CE} = V_{IN}$, $C_{IN} = C_{OUT} = 1\mu F$, $T_a = 25^{\circ}C$, unless otherwise noted)

Parameter	Symbol	Conditions	Min.	Typ.	Max.	Units
Output Voltage	$V_{OUT}(E)$ (Note 2)	$I_{OUT} = 10mA$, $V_{IN} = V_{OUT} + 1V$	X 0.98	$V_{OUT}(T)$ (Note 1)	X 1.02	V
Input Voltage	V_{IN}		2.8		18	V
Maximum Output Current	I_{OUTMAX}	$V_{IN} = V_{OUT} + 1V$		300	350	mA
Load Regulation	ΔV_{OUT}	$V_{IN} = V_{OUT} + 1V$, $1mA \leq I_{OUT} \leq 100mA$		4		mV
Dropout Voltage (Note 1)	V_{DIF1}	$I_{OUT} = 100mA$		160		mV
	V_{DIF2}	$I_{OUT} = 200mA$		320		mV
Supply Current	I_{SS}	$V_{IN} = V_{OUT} + 1V$		6		μA
Stand-by Current	I_{CEL}	$V_{CE} = 0V$		0		μA
Line Regulation	ΔV_{OUT}	$I_{OUT} = 30mA$ $V_{OUT} + 1V \leq V_{IN} \leq 18V$		30		mV
CE "High" Voltage	V_{CEH}	Start up	1.3			V
CE "Low" Voltage	V_{CEL}	Shut down			0.8	V
Short-circuit Current	I_{SHORT}	$V_{IN} = V_{OUT} + 1V$, $V_{CE} = V_{IN}$, $V_{OUT} = 0V$		25	50	mA
Over Current Protection	I_{limit}	$V_{IN} = 3.8V$		580	750	mA

Note :

- $V_{OUT}(T)$: Specified Output Voltage
- $V_{OUT}(E)$: Effective Output Voltage (i.e. The output voltage when " $V_{OUT}(T) + 1.0V$ " is provided at the V_{in} pin while maintaining a certain I_{out} value.)
- V_{DIF} : $V_{IN1} - V_{OUT}(E)'$
 V_{IN1} : The input voltage when $V_{OUT}(E)'$ appears as input voltage is gradually decreased.
 $V_{OUT}(E)'$ = A voltage equal to 98% of the output voltage whenever an amply stabilized I_{out} ($V_{OUT}(T) + 1.0V$) is input.

Type Characteristics (ME6215C28)

(1) Output Voltage VS. Output Current

($V_{IN}=V_{OUT}+1$, $T_a = 25\text{ }^\circ\text{C}$)

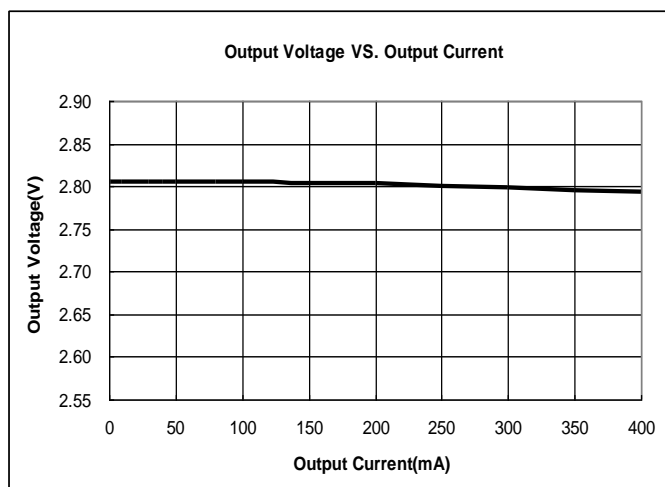

(2) Output Voltage VS. Input Voltage

($V_{IN}=V_{OUT}+1$, $I_{OUT} = 10\text{mA}$, $T_a = 25\text{ }^\circ\text{C}$)

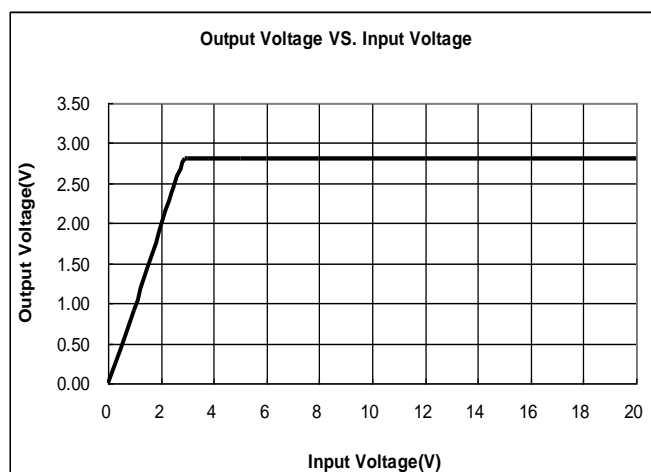

(3) Dropout Voltage VS. Output Current

($V_{IN}=V_{OUT}+1\text{V}$, $T_a = 25\text{ }^\circ\text{C}$)

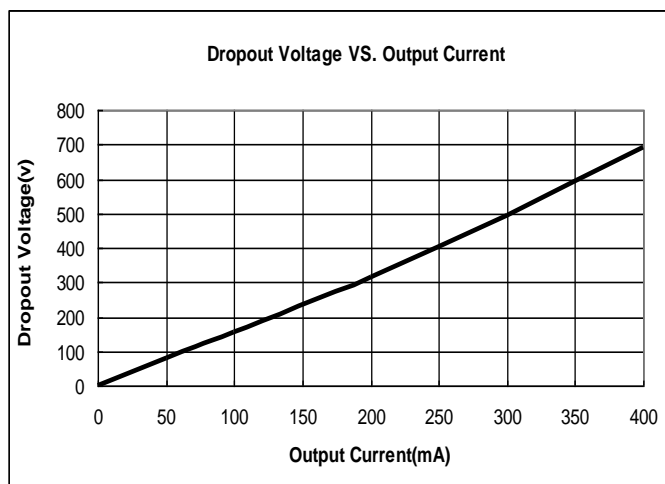

(4) Supply Current VS. Input Voltage

($T_a = 25\text{ }^\circ\text{C}$)

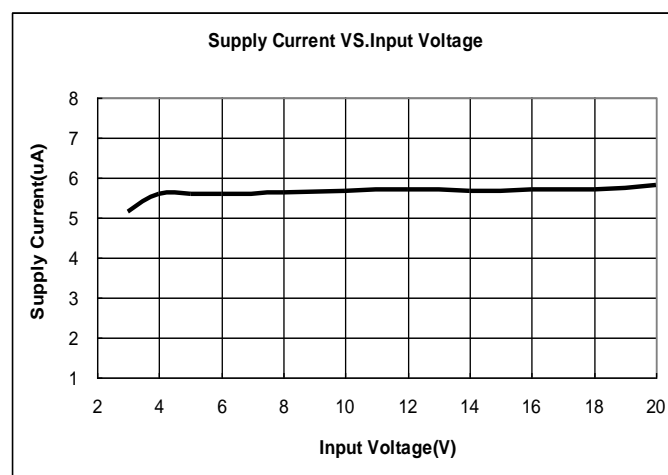

(5) Output Voltage VS. Temperature ($V_{IN}=V_{OUT}+1\text{V}$, $I_{OUT} = 10\text{mA}$)

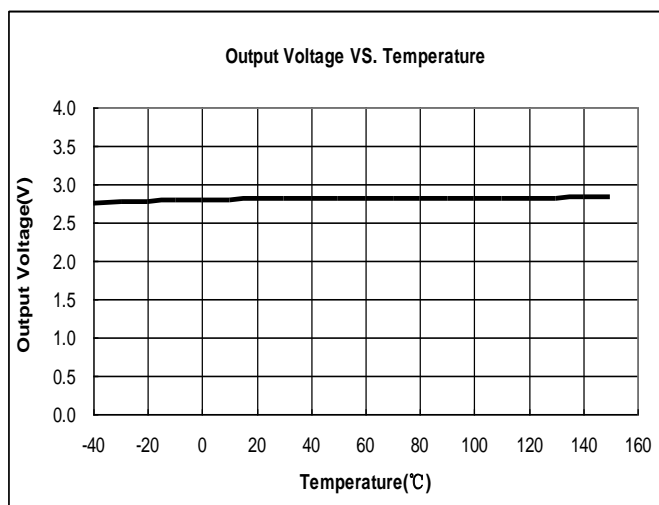

Packaging Information

Packaging Type: SOT23-5

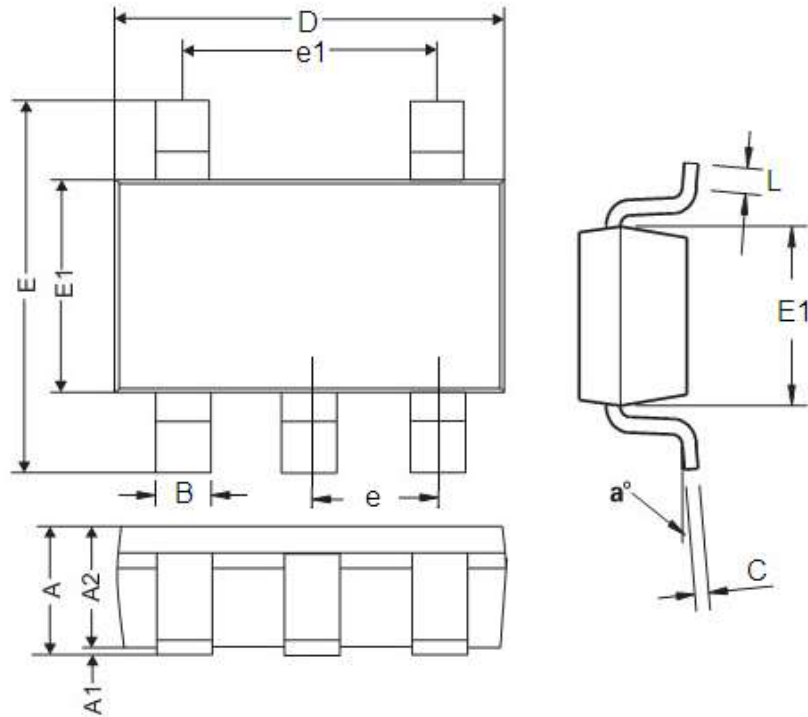

DIM	Millimeters		Inches	
	Min	Max	Min	Max
A	0.9	1.45	0.0354	0.0570
A1	0	0.15	0	0.0059
A2	0.9	1.3	0.0354	0.0511
B	0.2	0.5	0.0078	0.0196
C	0.09	0.26	0.0035	0.0102
D	2.7	3.10	0.1062	0.1220
E	2.2	3.2	0.0866	0.1181
E1	1.30	1.80	0.0511	0.0708
e	0.95REF		0.0374REF	
e1	1.90REF		0.0748REF	
L	0.10	0.60	0.0039	0.0236
a°	0°	30°	0°	30°

- The information described herein is subject to change without notice.
- Nanjing Micro One Electronics Inc is not responsible for any problems caused by circuits or diagrams described herein whose related industrial properties, patents, or other rights belong to third parties. The application circuit examples explain typical applications of the products, and do not guarantee the success of any specific mass-production design.
- Use of the information described herein for other purposes and/or reproduction or copying without the express permission of Nanjing Micro One Electronics Inc is strictly prohibited.
- The products described herein cannot be used as part of any device or equipment affecting the human body, such as exercise equipment, medical equipment, security systems, gas equipment, or any apparatus installed in airplanes and other vehicles, without prior written permission of Nanjing Micro One Electronics Inc.
- Although Nanjing Micro One Electronics Inc exerts the greatest possible effort to ensure high quality and reliability, the failure or malfunction of semiconductor products may occur. The user of these products should therefore give thorough consideration to safety design, including redundancy, fire-prevention measures, and malfunction prevention, to prevent any accidents, fires, or community damage that may ensue.

X-ON Electronics

Largest Supplier of Electrical and Electronic Components

Click to view similar products for [LDO Voltage Regulators](#) category:

Click to view products by [Micro One](#) manufacturer:

Other Similar products are found below :

[AP7363-SP-13](#) [L79M05TL-E](#) [AP7362-HA-7](#) [PT7M8202B12TA5EX](#) [TCR3DF185,LM\(CT](#) [TCR3DF45,LM\(CT](#) [TLE4473G V52](#)
[NCP4687DH15T1G](#) [701326R](#) [NCV8170AXV250T2G](#) [AP7315-25W5-7](#) [AP2111H-1.2TRG1](#) [ZLDO1117QK50TC](#) [AZ1117ID-ADJTRG1](#)
[TCR3DG12,LF](#) [MIC5514-3.3YMT-T5](#) [SCD7912BTG](#) [NCP154MX180270TAG](#) [SCD33269T-5.0G](#) [NCV8170BXV330T2G](#)
[NCV8170BMX330TCG](#) [NCV8170AMX120TCG](#) [NCP706ABMX300TAG](#) [NCP114BMX075TCG](#) [MC33269T-3.5G](#) [TCR3DG33,LF](#)
[TLE4471GXT](#) [TCR4DG35,LF](#) [TAR5S15U\(TE85L,F\)](#) [TCR3UG19A,LF](#) [TCR4DG105,LF](#) [MPQ2013AGG-5-P](#) [NCV8170AMX360TCG](#)
[AP7315-33SA-7](#) [TLE4268GSXUMA2](#) [NCP715SQ15T2G](#) [MIC5317-3.0YD5-T5](#) [NCV563SQ18T1G](#) [NCP715MX30TBG](#)
[NCV8702MX25TCG](#) [NCV8170BXV120T2G](#) [MIC5317-1.2YD5-T5](#) [NCV8170AMX150TCG](#) [NCV8170BMX150TCG](#) [AP2213D-3.3TRG1](#)
[NCV8170BMX120TCG](#) [NCV8170BMX310TCG](#) [NCV8170BMX360TCG](#) [MIC5514-1.2YMT-T5](#) [NCV8170BMX280TCG](#)