



## Low power consumption, Low ESR Cap. Compatible

### General Description

**ME6216** series are highly precise, low power consumption, positive voltage regulators manufactured using CMOS technologies. The series provides large currents with a significantly small dropout voltage.

The series is compatible with low ESR ceramic capacitors. The current limiter's foldback circuit also operates as a short protect for the output current limiter and the output pin.

### Features

- Output voltage range: 1.0V~5.0V
- Input voltage: up to 6 V
- Dropout Voltage: 110mV@  $I_{OUT} = 100mA$   
240mV@  $I_{OUT} = 200mA$
- Highly Accuracy:  $\pm 1\%$
- Low power consumption: 6 $\mu A$ (TYP.)
- Large output current: 300mA ( $V_{IN} = 4.3V, V_{OUT} = 3.3V$ )
- Excellent Input Stability
- Be available to regulator and reference voltage

### Typical Application

- Communication tools
- Mobile phones
- Portable games
- Portable AV systems
- Cameras, Video systems
- Reference voltage sources

### Package

- 3-pin SOT89-3, SOT23-3, SOT23, TO92, DFN3L

### Typical Application Circuit

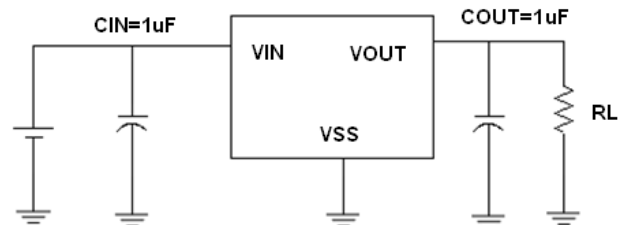

## Selection Guide

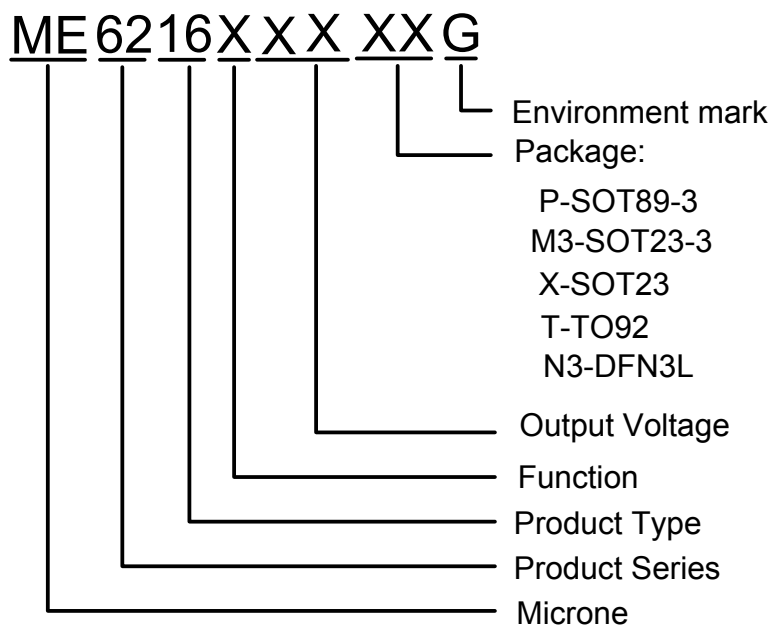

product series	product description
ME6216A10PG	V <sub>OUT</sub> =1.0V; Package: SOT89-3
ME6216A28M3G	V <sub>OUT</sub> =2.8V; Package: SOT23-3
ME6216A30XG	V <sub>OUT</sub> =3.0V; Package: SOT23
ME6216A18TG	V <sub>OUT</sub> =1.8V; Package: TO92
ME6216A18N3AG	V <sub>OUT</sub> =1.8V; Package: DFN3L(2.0*2.0*0.55-1.30)

### NOTE:

1. At present ,there are five kinds of voltage value: 1.0V、 1.2V、 1.3V、 1.5V、 1.8V、 2.0V、 2.5V、 2.7V、 2.8V、 3.0V、 3.3V、 3.6V、 5.0V。
2. If you need other voltage and package, please contact our sales staff。

## Pin Configuration

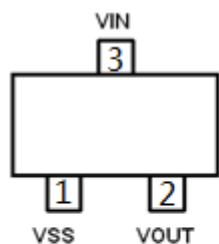

SOT23/SOT23-3

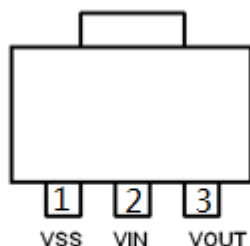

SOT89

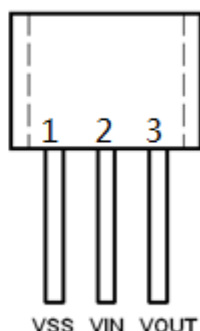

TO92

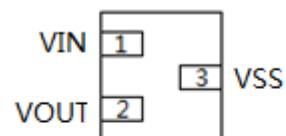

DFN3L

## Pin Assignment

### ME6216Axx

Pin					Name	Function
M3	P	X	T	N3		
SOT23-3	SOT89-3	SOT23	TO-92	DFN3L		
1	1	1	1	3	VSS	Ground
2	3	2	3	2	VOUT	Output
3	2	3	2	1	VIN	Input

## Block Diagram

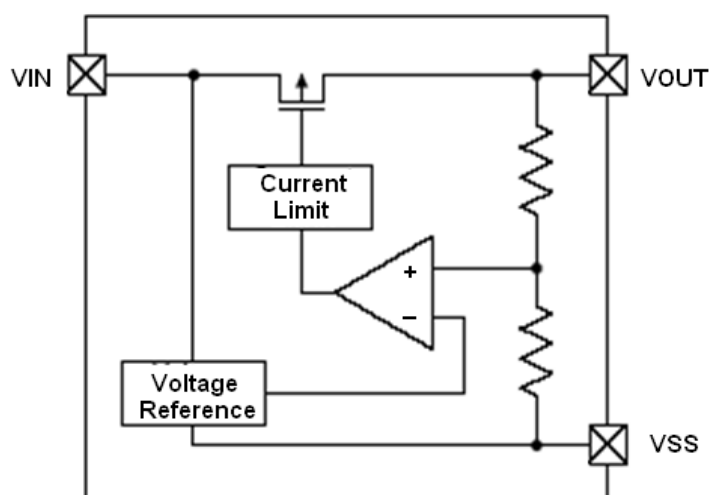

## Absolute Maximum Ratings

Parameter	Symbol	Description	Units	
Input Voltage	$V_{IN}$	6.5	V	
Output Current	$I_{OUT}$	390	mA	
Output Voltage	$V_{OUT}$	$V_{SS}-0.3 \sim V_{out}+0.3$	V	
Power Dissipation	SOT23-3	$P_d$	300	mW
	SOT89-3	$P_d$	500	mW
	SOT23	$P_d$	300	mW
	TO-92	$P_d$	500	mW
	DFN3L	$P_d$	500	mW
Operating Ambient Temperature	$T_{Opr}$	-25 ~ +125	°C	
Storage Temperature	$T_{stg}$	-40 ~ +125	°C	

## Electrical Characteristics

### ME6216 ( $V_{out}=1.2V$ )

( $V_{IN}=V_{OUT}+1V, C_{IN}=C_{OUT}=1\mu F, T_a=25^{\circ}C$  Unless otherwise stated)

PARAMETER	SYMBOL	CONDITION	MIX	TYP	MAX	UNIT
Output Voltage ( $V_{out}=1.0\sim 1.3V$ )	$V_{OUT(E)}$ (Note 2)	$I_{OUT}=10mA,$ $V_{IN}=V_{OUT}+1V$	$V_{OUT(T)}$ -0.015	$V_{OUT(T)}$ (Note 1)	$V_{OUT(T)}$ +0.015	V
Input Voltage	$V_{IN}$				6	V
Maximum Output Current	$I_{OUT(max)}$	$V_{IN}=V_{OUT}+1V$		250	280	mA
Load Regulation	$\Delta V_{OUT}$	$V_{IN}=V_{OUT}+1V$ $1mA \leq I_{OUT} \leq 100mA$		8	12	mV
Dropout Voltage (Note 3)	$V_{dif1}$	$I_{OUT}=100mA$		320	350	mV
	$V_{dif2}$	$I_{OUT}=200mA$		570	600	mV
Supply Current	$I_{SS}$	$V_{IN}=V_{OUT}+1V$		6	8	$\mu A$
Line Regulations	$\frac{\Delta V_{OUT}}{\Delta V_{IN} \cdot V_{OUT}}$	$I_{OUT}=10mA$ $V_{out}+1V \leq V_{IN} \leq 6V$		0.05	0.2	%/V
Power Supply Ripple Rejection Ratio	PSRR	$V_{in}=[V_{OUT}+1]V$ +1Vp-pAC $I_{OUT}=10mA, f=1kHz$		65		dB
Short Circuit Current	$I_{short}$	$V_{in}=V_{OUT(T)}+1V$ $V_{OUT}=V_{SS}$		50	70	mA
Over Current Protection	$I_{limit}$	$V_{IN}=V_{OUT}+1V$		310	340	mA

## ME6216 (Vout=1.8V)

( $V_{IN}=V_{OUT}+1V$ ,  $C_{IN}=C_{OUT}=1\mu F$ ,  $T_a=25^{\circ}C$  Unless otherwise stated)

PARAMETER	SYMBOL	CONDITION	MIX	TYP	MAX	UNIT
Output Voltage	$V_{OUT(E)}$ (Note 2)	$I_{OUT}=10mA$ , $V_{IN}=V_{OUT}+1V$	X 0.99	$V_{OUT(T)}$ (Note 1)	X 1.01	V
Input Voltage	$V_{IN}$				6	V
Maximum Output Current	$I_{OUT} (max)$	$V_{IN}= V_{OUT} +1V$		300	350	mA
Load Regulation	$\Delta V_{OUT}$	$V_{IN}= V_{OUT} +1V$ $1mA \leq I_{OUT} \leq 100mA$		8	12	mV
Dropout Voltage (Note 3)	$V_{dif1}$	$I_{OUT} =100mA$		190	210	mV
	$V_{dif2}$	$I_{OUT} =200mA$		380	400	mV
Supply Current	$I_{SS}$	$V_{IN}= V_{OUT} +1V$		6	8	$\mu A$
Line Regulations	$\frac{\Delta V_{OUT}}{\Delta V_{IN} \cdot V_{OUT}}$	$I_{OUT} =10mA$ $V_{out}+1V \leq V_{IN} \leq 6V$		0.05	0.2	%/V
Power Supply Ripple Rejection Ratio	PSRR	$V_{in}= [V_{OUT} +1]V$ $+1Vp-pAC$ $I_{OUT} =10mA, f=1kHz$		65		dB
Short Circuit Current	$I_{short}$	$V_{in}= V_{OUT} (T)+1V$ $V_{OUT} =VSS$		50	70	mA
Over Current Protection	$I_{limit}$	$V_{IN}= V_{OUT} +1V$		380	420	mA

## ME6216(Vout=2.8V)

( $V_{IN}=V_{OUT}+1V$ ,  $C_{IN}=C_{OUT}=1\mu F$ ,  $T_a=25^{\circ}C$  Unless otherwise stated)

PARAMETER	SYMBOL	CONDITION	MIX	TYP	MAX	UNIT
Output Voltage	$V_{OUT(E)}$ (Note 2)	$I_{OUT}=10mA$ , $V_{IN}=V_{OUT}+1V$	X 0.99	$V_{OUT(T)}$ (Note 1)	X 1.01	V
Input Voltage	$V_{IN}$				6	V
Maximum Output Current	$I_{OUT} (max)$	$V_{IN}= V_{OUT} +1V$		300	350	mA
Load Regulation	$\Delta V_{OUT}$	$V_{IN}= V_{OUT} +1V$ $1mA \leq I_{OUT} \leq 100mA$		8	14	mV
Dropout Voltage (Note 3)	$V_{dif1}$	$I_{OUT} =100mA$		120	140	mV
	$V_{dif2}$	$I_{OUT} =200mA$		230	250	mV
Supply Current	$I_{SS}$	$V_{IN}= V_{OUT} +1V$		5	8	$\mu A$
Line Regulations	$\frac{\Delta V_{OUT}}{\Delta V_{IN} \cdot V_{OUT}}$	$I_{OUT} =10mA$ $V_{out}+1V \leq V_{IN} \leq 6V$		0.05	0.2	%/V
Power Supply Ripple Rejection Ratio	PSRR	$V_{in}= [V_{OUT} +1]V$ $+1Vp-pAC$ $I_{OUT} =10mA, f=1kHz$		65		dB
Short Circuit Current	$I_{short}$	$V_{in}= V_{OUT} (T)+1V$ $V_{OUT} =VSS$		50	70	mA
Over Current Protection	$I_{limit}$	$V_{IN}= V_{OUT} +1V$		380	420	mA

## ME6216(Vout=3.3V)

( $V_{IN}=V_{OUT}+1V$ ,  $C_{IN}=C_{OUT}=1\mu F$ ,  $T_a=25^{\circ}C$  Unless otherwise stated)

PARAMETER	SYMBOL	CONDITION	MIX	TYP	MAX	UNIT
Output Voltage	$V_{OUT(E)}$ (Note 2)	$I_{OUT}=10mA$ , $V_{IN}=V_{OUT}+1V$	X 0.99	$V_{OUT(T)}$ (Note 1)	X 1.01	V
Input Voltage	$V_{IN}$				6	V
Maximum Output Current	$I_{OUT}$ (max)	$V_{IN}=V_{OUT}+1V$		300	350	mA
Load Regulation	$\Delta V_{OUT}$	$V_{IN}=V_{OUT}+1V$ $1mA \leq I_{OUT} \leq 100mA$		14	18	mV
Dropout Voltage (Note 3)	$V_{dif1}$	$I_{OUT}=100mA$		100	120	mV
	$V_{dif2}$	$I_{OUT}=200mA$		210	260	mV
Supply Current	$I_{SS}$	$V_{IN}=V_{OUT}+1V$		4	8	$\mu A$
Line Regulations	$\frac{\Delta V_{OUT}}{\Delta V_{IN} \cdot V_{OUT}}$	$I_{OUT}=10mA$ $V_{out}+1V \leq V_{IN} \leq 6V$		0.07	0.2	%/V
Power Supply Ripple Rejection Ratio	PSRR	$V_{in}=[V_{OUT}+1]V$ $+1V_{p-pAC}$ $I_{OUT}=10mA, f=1kHz$		65		dB
Short Circuit Current	$I_{short}$	$V_{in}=V_{OUT}(T)+1V$ $V_{OUT}=V_{SS}$		50	70	mA
Over Current Protection	$I_{limit}$	$V_{IN}=V_{OUT}+1V$		380	420	mA

## ME6216(Vout=5.0V)

( $V_{IN}=V_{OUT}+1V$ ,  $C_{IN}=C_{OUT}=1\mu F$ ,  $T_a=25^{\circ}C$  Unless otherwise stated)

PARAMETER	SYMBOL	CONDITION	MIX	TYP	MAX	UNIT
Output Voltage	$V_{OUT(E)}$ (Note 2)	$I_{OUT}=10mA$ , $V_{IN}=V_{OUT}+1V$	X 0.99	$V_{OUT(T)}$ (Note 1)	X 1.01	V
Input Voltage	$V_{IN}$				6	V
Maximum Output Current	$I_{OUT}$ (max)	$V_{IN}=V_{OUT}+1V$		500	550	mA
Load Regulation	$\Delta V_{OUT}$	$V_{IN}=V_{OUT}+1V$ $1mA \leq I_{OUT} \leq 100mA$		8	14	mV
Dropout Voltage (Note 3)	$V_{dif1}$	$I_{OUT}=100mA$		90	110	mV
	$V_{dif2}$	$I_{OUT}=200mA$		170	200	mV
Supply Current	$I_{SS}$	$V_{IN}=V_{OUT}+1V$		7	8	$\mu A$
Power Supply Ripple Rejection Ratio	PSRR	$V_{in}=[V_{OUT}+1]V$ $+1V_{p-pAC}$ $I_{OUT}=10mA, f=1kHz$		65		dB
Short Circuit Current	$I_{short}$	$V_{in}=V_{OUT}(T)+1V$ $V_{OUT}=V_{SS}$		50	70	mA
Over Current Protection	$I_{limit}$	$V_{IN}=V_{OUT}+1V$		550	600	mA

**Note :**

1.  $V_{OUT}(T)$  : Specified Output Voltage
2.  $V_{OUT}(E)$  : Effective Output Voltage ( i.e. The output voltage when " $V_{OUT}(T)+1.0V$ " is provided at the Vin pin while maintaining a certain  $I_{OUT}$  value.)
3.  $V_{dif}$  :  $V_{IN1} - V_{OUT}(E)$   
 $V_{IN1}$  : The input voltage when  $V_{OUT}(E)$  appears as input voltage is gradually decreased.  
 $V_{OUT}(E)$  : A voltage equal to 98% of the output voltage whenever an amply stabilized  $I_{OUT} \{V_{OUT}(T)+1.0V\}$  is input.

## Type Characteristics ( ME6216A33 )

(1) Output Voltage VS. Output Current  
( $V_{IN}=V_{OUT}+1, T_a = 25^\circ C$ )

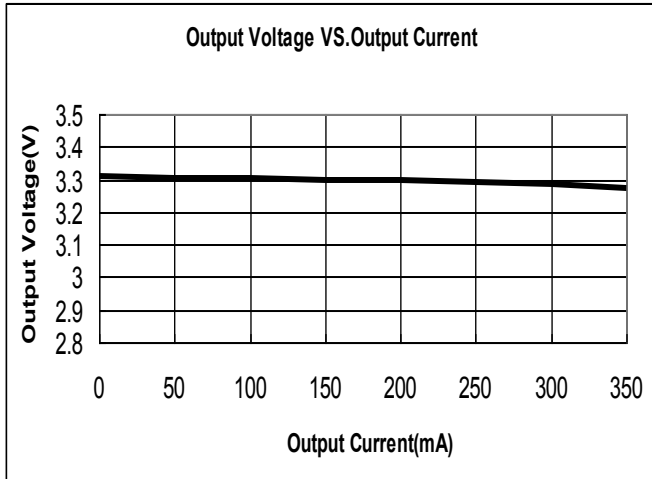

(2) Output Voltage VS. Input Voltage  
( $T_a = 25^\circ C$ )

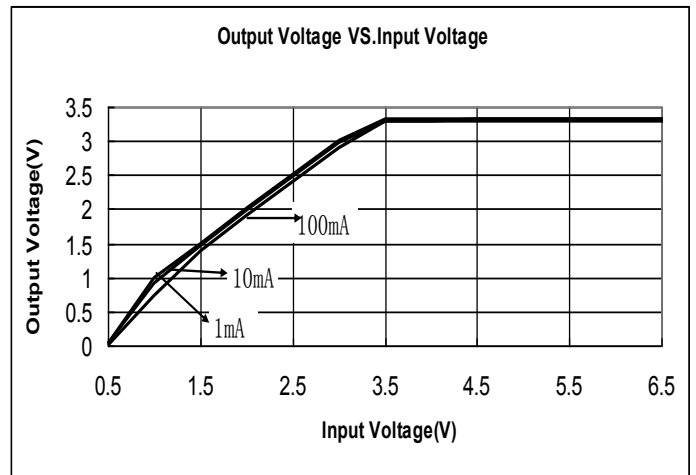

(3) Dropout Voltage VS. Output Current  
( $V_{IN}=V_{OUT}+1V, T_a = 25^\circ C$ )

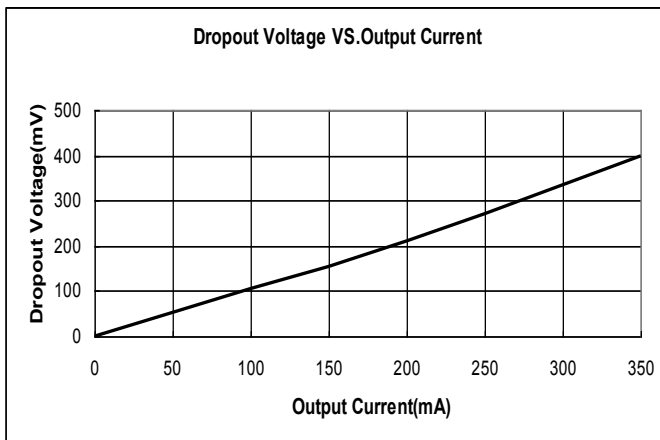

(4) Supply Current VS. Input Voltage  
( $T_a = 25^\circ C$ )

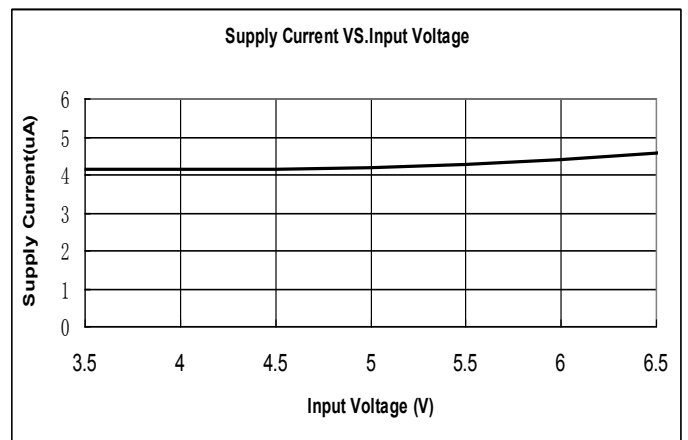

(5) Output Voltage VS. Temperature ( $V_{IN}=V_{OUT}+1V$ ,  $I_{OUT}=10mA$ )

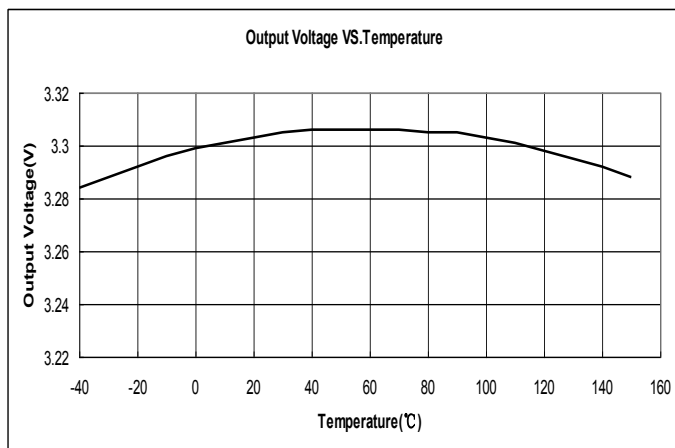



## Packaging Information

- SOT89-3

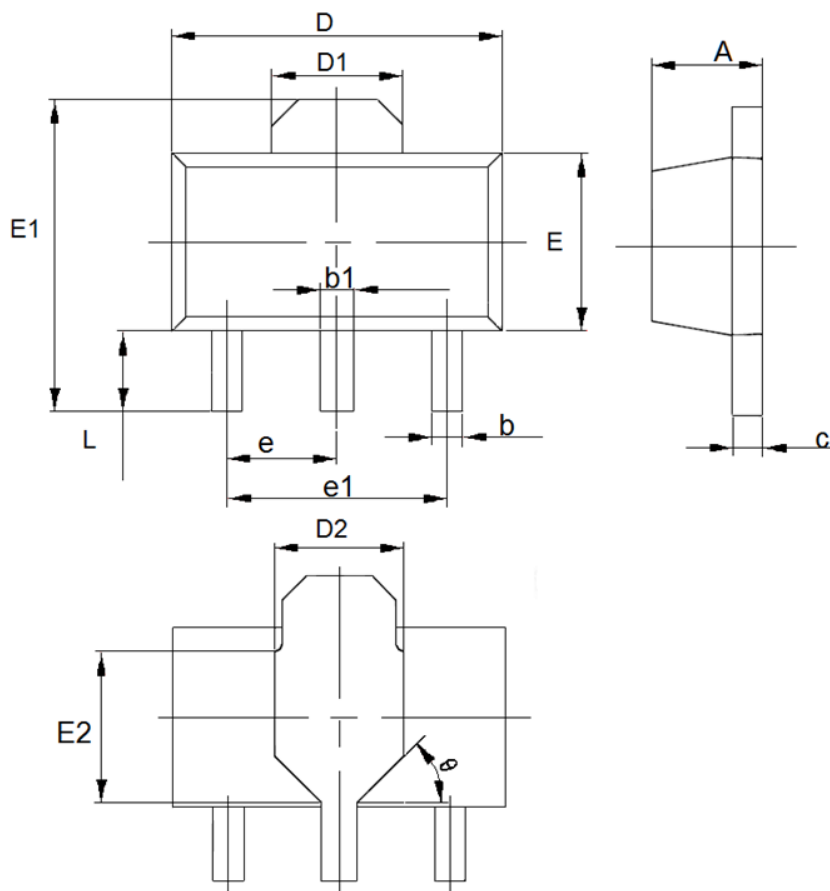

DIM	Millimeters		Inches	
	Min	Max	Min	Max
A	1.4	1.6	0.0551	0.063
b	0.32	0.52	0.0126	0.0205
b1	0.4	0.58	0.0157	0.0228
c	0.35	0.45	0.0138	0.01772
D	4.4	4.6	0.1732	0.1811
D1	1.55(TYP)		0.061(TYP)	
D2	1.75(TYP)		0.0689(TYP)	
e1	3(TYP)		0.1181(TYP)	
E	2.3	2.6	0.0906	0.1023
E1	3.94	4.4	0.1551	0.1732
E2	1.9(TYP)		0.0748(TYP)	
e	1.5(TYP)		0.0591(TYP)	
L	0.8	1.2	0.0315	0.0472
θ	45°		45°	

● SOT23-3

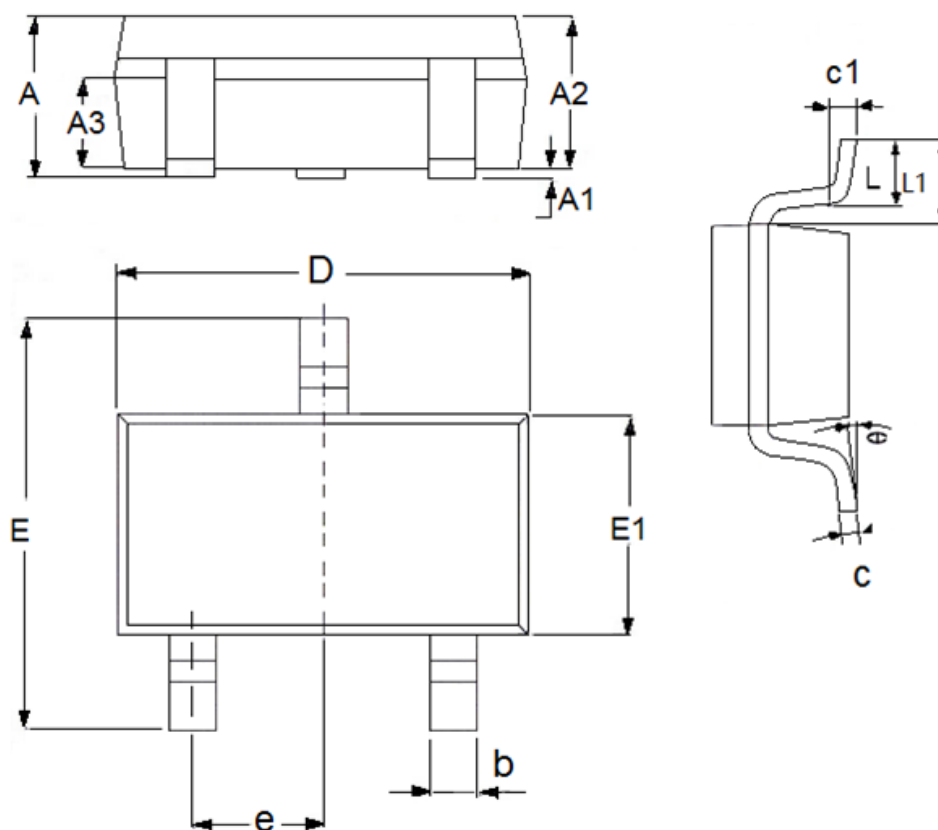

DIM	Millimeters		Inches	
	Min	Max	Min	Max
A	1	1.5	0.0394	0.0591
A1	0	0.15	0	0.0059
A2	0.9	1.3	0.0354	0.0512
A3	0.6	0.7	0.0236	0.0276
b	0.25	0.5	0.0098	0.0197
c	0.1	0.25	0.0039	0.0098
D	2.8	3.1	0.1102	0.122
E	2.6	3.1	0.1023	0.122
E1	1.5	1.8	0.0591	0.0709
e	0.95(TYP)		0.0374(TYP)	
L	0.25	0.6	0.0098	0.0236
L1	0.59(TYP)		0.0232(TYP)	
θ	0	8°	0	8°
c1	0.2(TYP)		0.0079(TYP)	

● SOT23

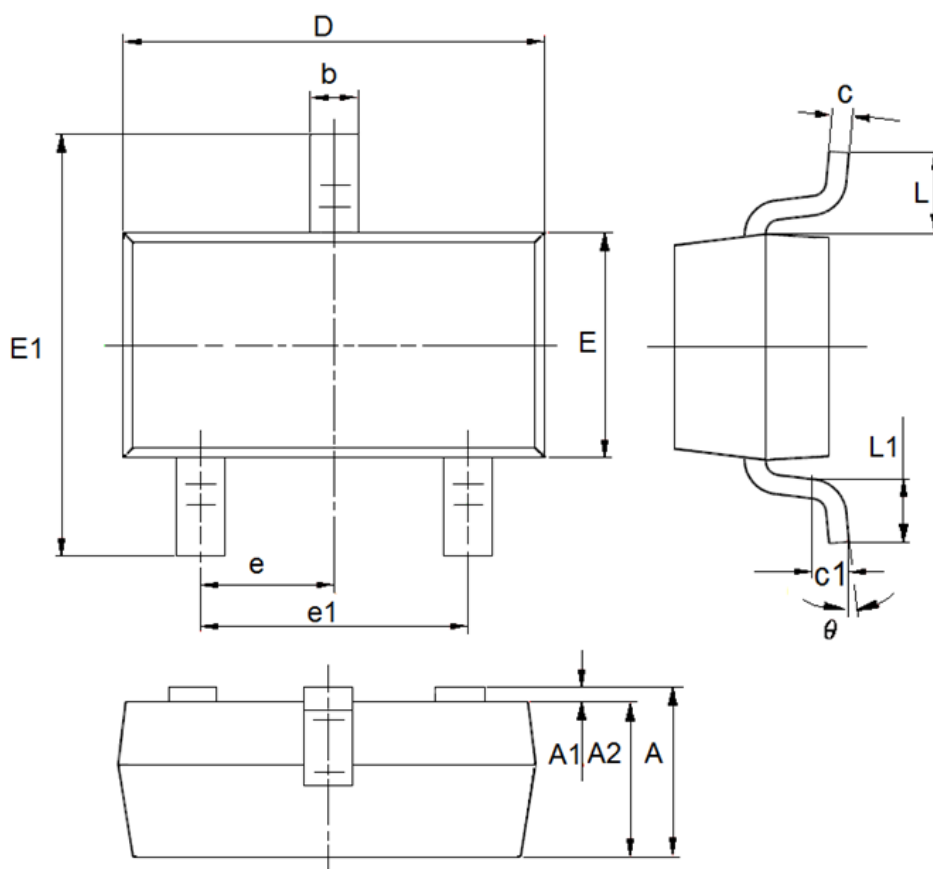

DIM	Millimeters		Inches	
	Min	Max	Min	Max
A	0.9	1.15	0.0354	0.0453
A1	0	0.14	0	0.0055
A2	0.9	1.05	0.0354	0.0413
b	0.28	0.52	0.011	0.0205
c	0.07	0.23	0.0028	0.0091
D	2.8	3	0.1102	0.1181
e1	1.8	2	0.0709	0.0787
E	1.2	1.4	0.0472	0.0551
E1	2.25	2.55	0.0886	0.1004
e	0.95(TYP)		0.0374(TYP)	
L	0.55(TYP)		0.0217(TYP)	
L1	0.25	0.55	0.0098	0.0217
$\theta$	0	8°	0	8°
c1	0.25(TYP)		0.0098(TYP)	

● TO-92

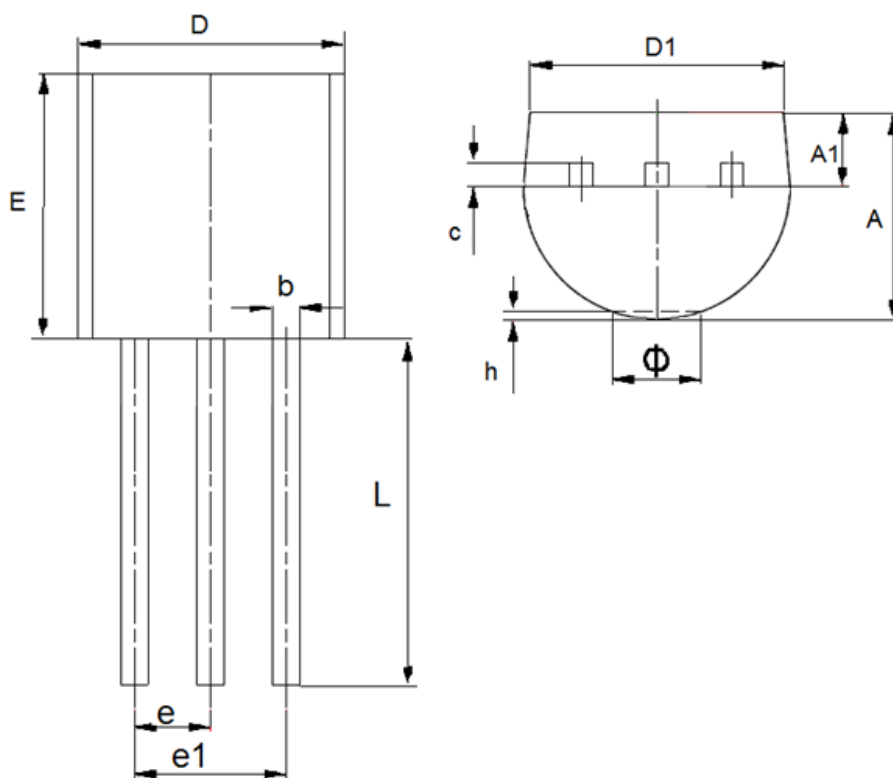

DIM	Millimeters		Inches	
	Min	Max	Min	Max
A	3.3	3.7	0.1299	0.1457
A1	1.1	1.4	0.0433	0.0551
b	0.38	0.55	0.015	0.0217
c	0.36	0.51	0.0142	0.0201
D	4.3	4.7	0.1693	0.185
D1	3.43	—	0.135	—
E	4.3	4.7	0.1693	0.185
e	1.27		0.05	
e1	2.44	2.64	0.0961	0.1039
L	14.1	14.5	0.5551	0.5709
h	0	0.38	0	0.015
Φ	—	1.6	—	0.063

● DFN3L(2.0\*2.0\*0.55-1.30)

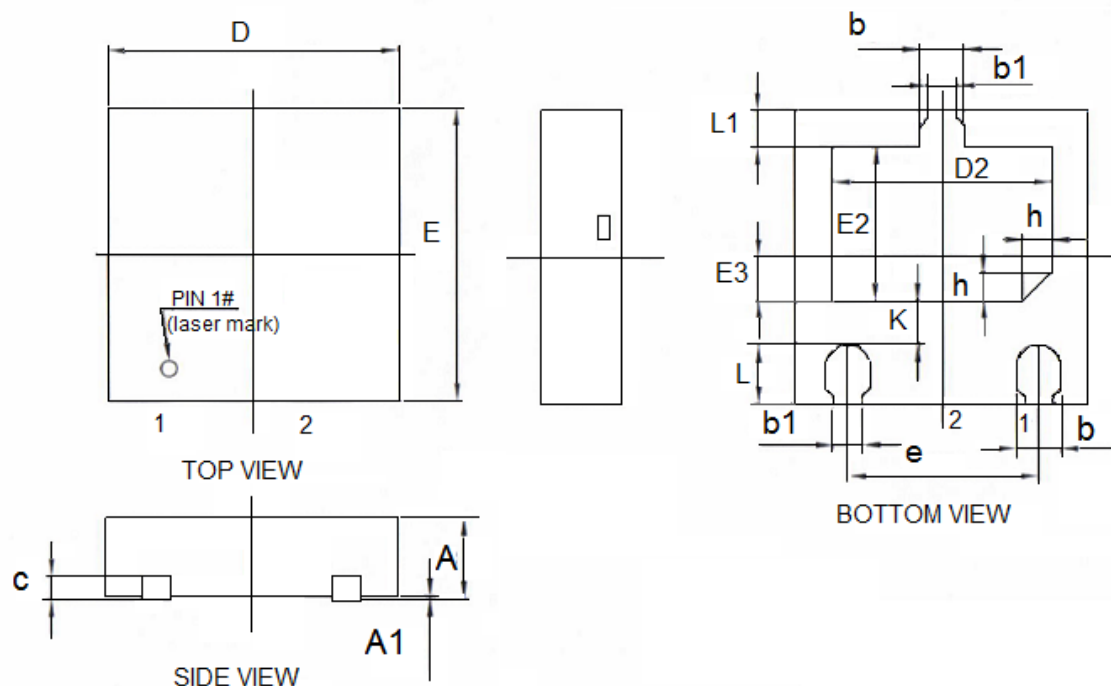

DIM	Millimeters		Inches	
	Min	Max	Min	Max
A	0.5	0.6	0.0197	0.0236
A1	0	0.05	0	0.002
c	0.152REF		0.006REF	
b	0.25	0.35	0.0098	0.0138
D	1.9	2.1	0.0748	0.0827
b1	0.2REF		0.0079REF	
E	1.9	2.1	0.0748	0.0827
E2	0.95	1.15	0.0374	0.0453
E3	0.2	0.4	0.0079	0.0157
e	1.3BSC		0.0512BSC	
L	0.35	0.45	0.0138	0.0177
L1	0.2	0.3	0.00787402	0.01181103
h	0.2REF		0.0079REF	
D2	1.4	1.6	0.0551	0.063
K	0.2	0.4	0.0079	0.01579

- The information described herein is subject to change without notice.
- Nanjing Micro One Electronics Inc is not responsible for any problems caused by circuits or diagrams described herein whose related industrial properties, patents, or other rights belong to third parties. The application circuit examples explain typical applications of the products, and do not guarantee the success of any specific mass-production design.
- Use of the information described herein for other purposes and/or reproduction or copying without the express permission of Nanjing Micro One Electronics Inc is strictly prohibited.
- The products described herein cannot be used as part of any device or equipment affecting the human body, such as exercise equipment, medical equipment, security systems, gas equipment, or any apparatus installed in airplanes and other vehicles, without prior written permission of Nanjing Micro One Electronics Inc.
- Although Nanjing Micro One Electronics Inc exerts the greatest possible effort to ensure high quality and reliability, the failure or malfunction of semiconductor products may occur. The user of these products should therefore give thorough consideration to safety design, including redundancy, fire-prevention measures, and malfunction prevention, to prevent any accidents, fires, or community damage that may ensue.

## X-ON Electronics

Largest Supplier of Electrical and Electronic Components

*Click to view similar products for [LDO Voltage Regulators](#) category:*

*Click to view products by [Micro One](#) manufacturer:*

Other Similar products are found below :

[M38D29FFHP#U1](#) [702103A](#) [717726C](#) [742457H](#) [MP20051DN-LF-Z](#) [R5F111PGGFB#30](#) [AP7363-SP-13](#) [NCP103AMX285TCG](#)  
[NCV8664CST33T3G](#) [NCV8752AMX28TCG](#) [L9454](#) [AP7362-HA-7](#) [LX13043CLD](#) [TCR3DF185,LM\(CT](#) [TCR3DF24,LM\(CT](#)  
[TCR3DF285,LM\(CT](#) [TCR3DF31,LM\(CT](#) [TCR3DF45,LM\(CT](#) [TLF4949EJ](#) [L9708](#) [L970813TR](#) [030014BB](#) [059985X](#) [EAN61387601](#)  
[EAN61573601](#) [NCP121AMX173TCG](#) [NCP4687DH15T1G](#) [NCV8703MX30TCG](#) [701326R](#) [702087BB](#) [755078E](#) [TCR2EN28,LF\(S](#)  
[LM1117DT-1.8/NO](#) [LT1086CM#TRPBF](#) [AZ1085S2-1.5TRE1](#) [MAX15101EWL+T](#) [NCV8170AXV250T2G](#) [SCD337BTG](#)  
[TCR3DF27,LM\(CT](#) [TCR3DF19,LM\(CT](#) [TCR3DF125,LM\(CT](#) [TCR2EN18,LF\(S](#) [MAX15103EWL+T](#) [TS2937CZ-5.0 C0](#) [MAX8878EUK30-](#)  
[T](#) [MAX663CPA](#) [NCV4269CPD50R2G](#) [NCV8716MT30TBG](#) [AZ1117IH-1.2TRG1](#) [MP2013GQ-P](#)