

High Output Current LDO Regulator , High PSRR , Low Dropout, ME6207 Series

General Description

The ME6217 Series is a positive voltage regulator with a low dropout voltage, high output voltage accuracy, and low current consumption developed based on CMOS technology.

A built-in low on-resistance transistor provides a low dropout voltage and large output current, a built-in overcurrent protector prevents the load current from exceeding the current capacitance of the output transistor. An ON/OFF circuit ensures a long battery life. Compared with the voltage regulators using the conventional CMOS process, a larger variety of capacitors are available, including small ceramic capacitors.

Features

- Maximum Output Current: 800 mA ($V_{IN} \geq V_{OUT(T)} + 1.0V$)
- Dropout Voltage: 100mV @ $I_{OUT} = 300mA, V_{OUT} = 5.0V$
- Operating Voltage Range: 2V~6.5V
- Output Voltage: 1.5V~5.6V , selectable in 0.1V steps
- Highly Accuracy: $\pm 1\%$
- Low Current Consumption:
During Operation: 100uA (TYP.)
During Shutdown: 0.1uA (TYP.)
- High Ripple Rejection: 65dB@1KHz (ME6217C50)
- Line Regulation: 0.05% (TYP.)
- Thermal Shutdown Protection: 160°C
- Small Packages: SOT-89-5, SOT23-5, SOT89-3

Selection Guide

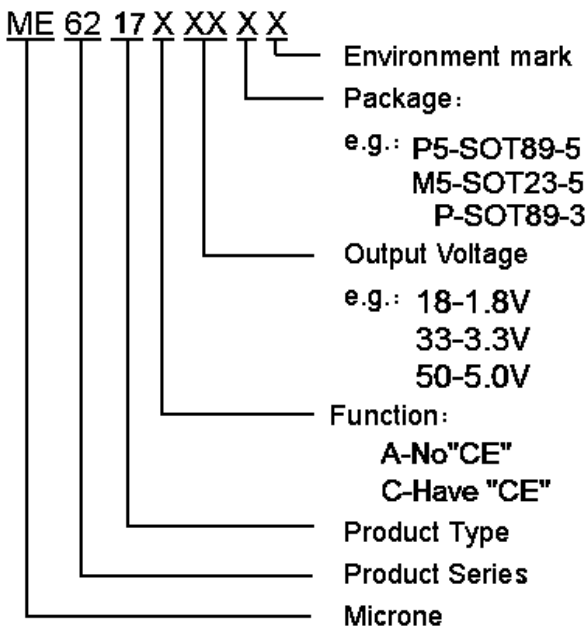

Typical Application

- Power supply for DVD and CD-ROM drives
- Power supply for personal communication device
- Power supply for battery-powered devices
- Power supply for note PCs

Typical Application Circuit

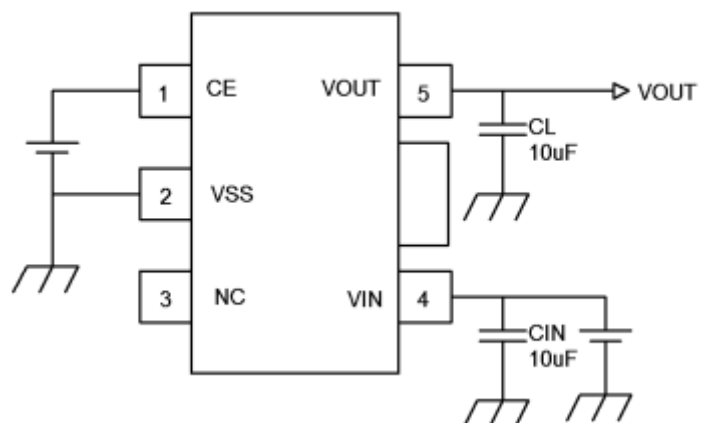

Pin Configuration

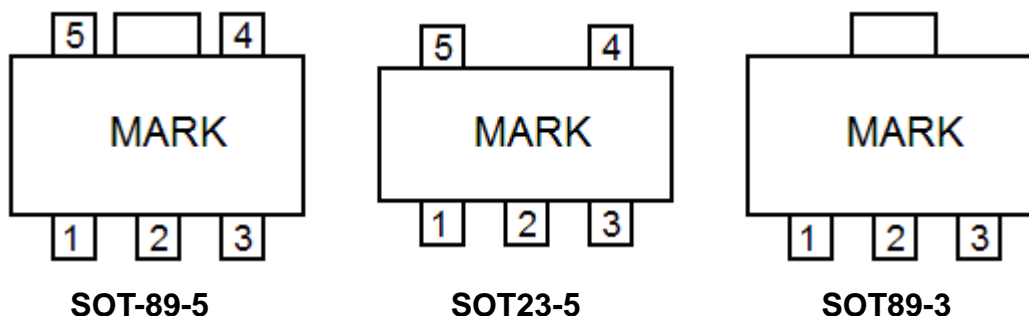

Pin Assignment

ME6217AXX

Pin Number	Pin Name	Functions
SOT89-3		
1	V_{SS}	Ground
2	V_{IN}	Input Voltage
3	V_{OUT}	Output Voltage

ME6217CXX

Pin Number		Pin Name	Functions
SOT89-5	SOT23-5		
1	3	CE	ON / OFF Control
2	2	V_{SS}	Ground
3	4	NC	No Connect
4	1	V_{IN}	Input Voltage
5	5	V_{OUT}	Output Voltage

Absolute Maximum Ratings

Parameter	Symbol	Ratings	Units
Input Voltage	V_{IN}	7.0	V
Output Current	I_{OUT}	800	mA
Output Voltage	V_{OUT}	$V_{SS}-0.3 \sim V_{IN} + 0.3$	V
CE Pin Voltage	V_{CE}	$V_{SS}-0.3 \sim V_{IN} + 0.3$	V
Power Dissipation	P_D	1000	mW
Operating Temperature Range	T_{OPR}	$-40 \sim +85$	$^{\circ}C$
Storage Temperature Range	T_{STG}	$-40 \sim +125$	$^{\circ}C$

Block Diagram

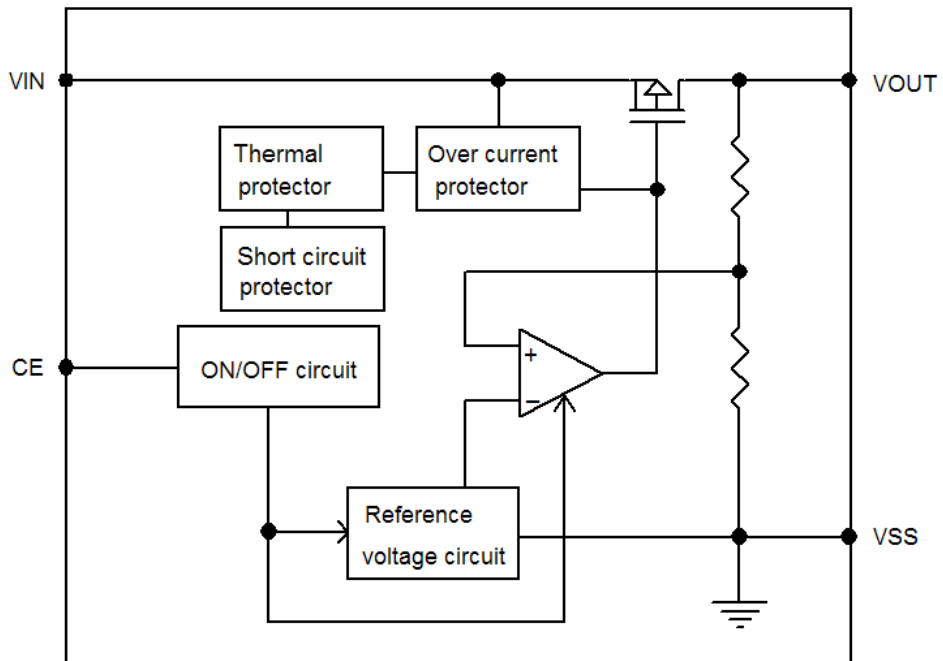

Electrical Characteristics

($V_{IN} = V_{OUT}(T) + 1.0V$, $V_{CE} = V_{IN}$, $C_{IN} = C_L = 10\mu F$, $T_a = 25^\circ C$, unless otherwise noted)

Parameter	Symbol	Conditions	Min.	Typ.	Max.	Units	
Output Voltage	$V_{OUT(E)}$ (Note 2)	$I_{OUT} = 100mA$	X 0.99	$V_{OUT}(T)$ (Note 1)	X 1.01	V	
Input voltage	V_{IN}	-	2.0	-	6.5	V	
Maximum Output Current	I_{OUTMAX} (Note 4)	$V_{IN} \geq V_{OUT}(T) + 1.0V$	-	800	-	mA	
Load Regulation	ΔV_{OUT}	$1mA \leq I_{OUT} \leq 300mA$	-	10	50	mV	
Line Regulation	$\frac{\Delta V_{OUT}}{\Delta V_{IN} \cdot V_{OUT}}$	$I_{OUT} = 100mA$ $V_{OUT}(T) + 0.5V \leq V_{IN} \leq 6.5V$	-	0.1	0.3	%/V	
Dropout Voltage	V_{DIF} (Note 3)	$I_{OUT} = 300mA$	$1.8V \leq V_{OUT}(T) \leq 2.0V$	-	200	260	mV
			$3.0V \leq V_{OUT}(T) \leq 5.5V$	-	100	180	
Current consumption during operation	I_{SS1}	CE pin = ON, no load	-	100	130	μA	
Current consumption during shutdown	I_{SS2}	CE pin = OFF, no load	-	0.1	1.0	μA	
CE "High" Voltage	V_{CEH}	Start up, $R_L = 1.0K\Omega$	1.5	-	-	V	
CE "Low" Voltage	V_{CEL}	Shut down, $R_L = 1.0K\Omega$	-	-	0.3	V	
CE "High" Current	I_{CEH}	$V_{IN} = 6.5V, V_{CE} = 6.5V$	-0.1	-	0.1	μA	
CE "Low" Current	I_{CEL}	$V_{IN} = 6.5V, V_{CE} = 0V$	-0.1	-	0.1	μA	
Ripple Rejection Rate	RR	$V_{IN} = 6V$, $\Delta V_{rip} = 0.5V_{rms}$, $I_{OUT} = 100mA$, $f = 1kHz$	$1.8V \leq V_{OUT}(T) \leq 2.0V$	-	70	-	dB
			$3.0V \leq V_{OUT}(T) \leq 5.5V$	-	65	-	
Short-circuit current	I_{short}	CE pin = ON, $V_{OUT} = 0V$	-	350	-	mA	
Thermal Shutdown Protection	T_{sd}	$I_{OUT} = 1mA, V_{IN} = V_{OUT} + 1V$		160		$^\circ C$	

Note :

- $V_{OUT}(T)$: Specified Output Voltage
- $V_{OUT}(E)$: Effective Output Voltage (i.e. The output voltage when " $V_{OUT}(T) + 1.0V$ " is provided at the Vin pin while maintaining a certain Iout value.)
- $V_{DIF} = V_{IN1} - V_{OUT}(E)$
 V_{IN1} : The input voltage when $V_{OUT}(E)$ appears as input voltage is gradually decreased.
 $V_{OUT}(E)$ = A voltage equal to 98% of the output voltage whenever an amply stabilized Iout { $V_{OUT}(T) + 1.0V$ } is input.
- I_{OUTMAX} : Due to restrictions on the package power dissipation, this value may not be satisfied. Attention should be paid to the power dissipation of the package when the output current is large. This specification is guaranteed by design.

Operation

1. Basic operation

Figure 1 shows the block diagram of the ME6217 Series.

The error amplifier compares the reference voltage (V_{ref}) with V_{fb} , which is the output voltage resistance-divided by feedback resistors R_s and R_f . It supplies the output transistor with the gate voltage necessary to ensure a certain output voltage free of any fluctuations of input voltage and temperature.

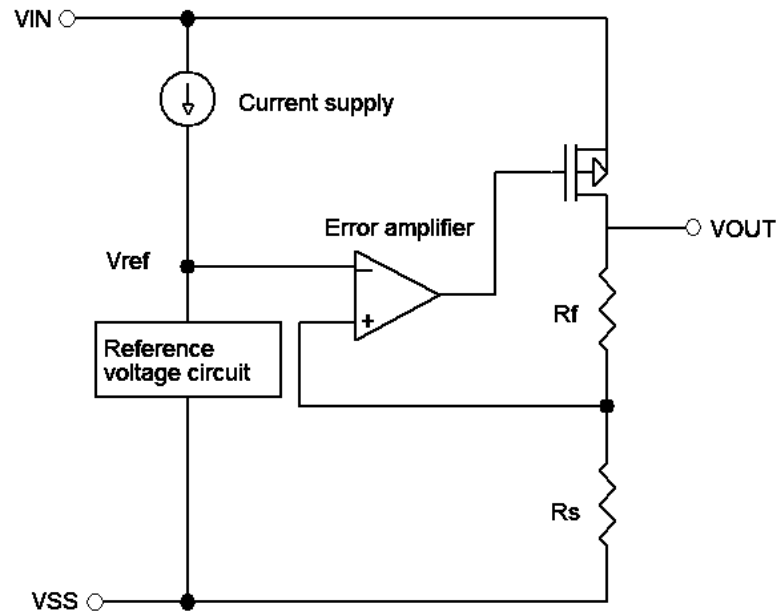

Figure 1

2. Output transistor

The ME6217 Series uses a low on-resistance P-channel MOS FET as the output transistor. Be sure that V_{OUT} does not exceed $V_{IN} + 0.3\text{ V}$ to prevent the voltage regulator from being damaged due to inverse current flowing from V_{OUT} pin through a parasitic diode to V_{IN} pin.

3. Shutdown pin (CE pin)

This pin starts and stops the regulator.

When the CE pin is set to the shutdown level, the operation of all internal circuits stops, and the built-in P-channel MOS FET output transistor between the V_{IN} pin and V_{OUT} pin is turned off to substantially reduce the current consumption. The V_{OUT} pin becomes the V_{SS} level due to the internally divided resistance of several hundreds $k\Omega$ between the V_{OUT} pin and V_{SS} pin. Since the CE pin is neither pulled down nor pulled up internally, do not use it in the floating state. In addition, note that the current consumption increases if a voltage of 0.3 V to $V_{IN} - 0.3\text{ V}$ is applied to the CE pin.

Table 1

CE Pin	Internal Circuits	V_{OUT} Pin Voltage	Current Consumption
"H" Power on	Operating	Set value	I_{SS1}
"L" Power off	Stopped	V_{SS} level	I_{SS2}

Precautions

1. Wiring patterns for the VIN, VOUT and GND pins should be designed so that the impedance is low. When mounting an output capacitor between the VOUT and VSS pins (CL) and a capacitor for stabilizing the input between VIN and VSS pins (CIN), the distance from the capacitors to these pins should be as short as possible.
2. Note that the output voltage may increase when a series regulator is used at low load current (1.0 mA or less).
3. Generally a series regulator may cause oscillation, depending on the selection of external parts. The following conditions are recommended for this IC. However, be sure to perform sufficient evaluation under the actual usage conditions for selection, including evaluation of temperature characteristics.

Input capacitor (CIN): 4.7 μ F or more

Output capacitor (CL): 4.7 μ F or more

Equivalent series resistance (ESR): 0.5 Ω or less

4. The voltage regulator may oscillate when the impedance of the power supply is high and the input capacitor is small or an input capacitor is not connected.
5. The application conditions for the input voltage, output voltage, and load current should not exceed the package power dissipation.
6. Do not apply an electrostatic discharge to this IC that exceeds the performance ratings of the built-in electrostatic protection circuit.
7. SII claims no responsibility for any disputes arising out of or in connection with any infringement by products including this IC of patents owned by a third party.

Type Characteristics

- (1) Input Voltage VS. Output Voltage ($T_a = 25\text{ }^\circ\text{C}$)
ME6217C50P5G

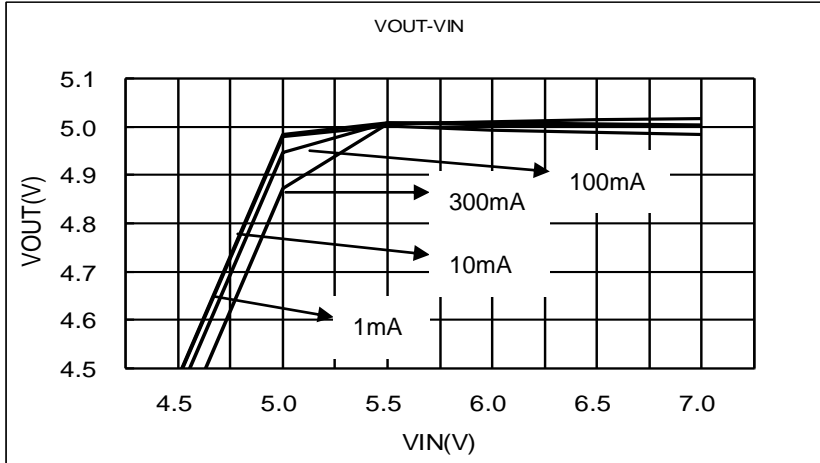

- (2) Output Current VS. Dropout Voltage ($V_{IN} = V_{OUT} (T) + 1.0V, T_a = 25\text{ }^\circ\text{C}$)
ME6217C50P5G

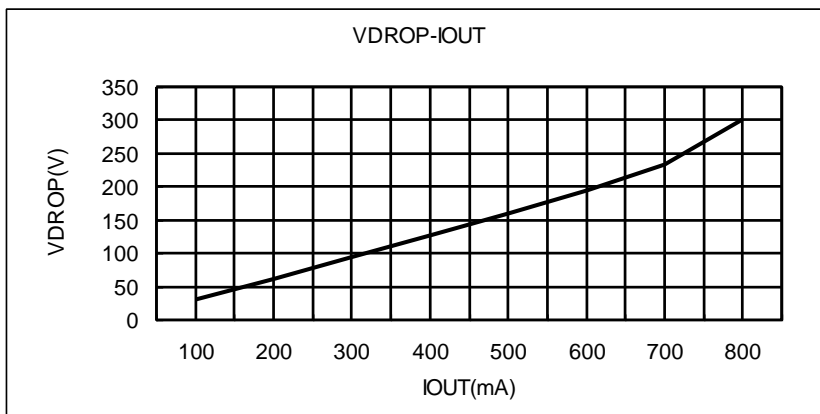

- (3) Input Voltage VS. Current Consumption ($T_a = 25\text{ }^\circ\text{C}$)
ME6217C50P5G

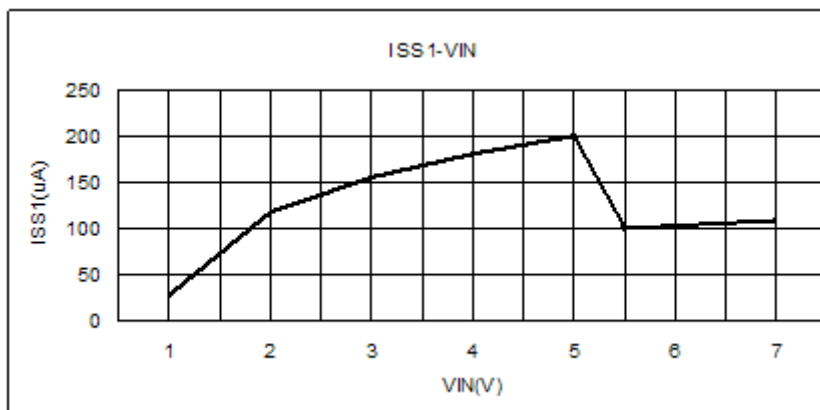

Package Information:

SOT89-5

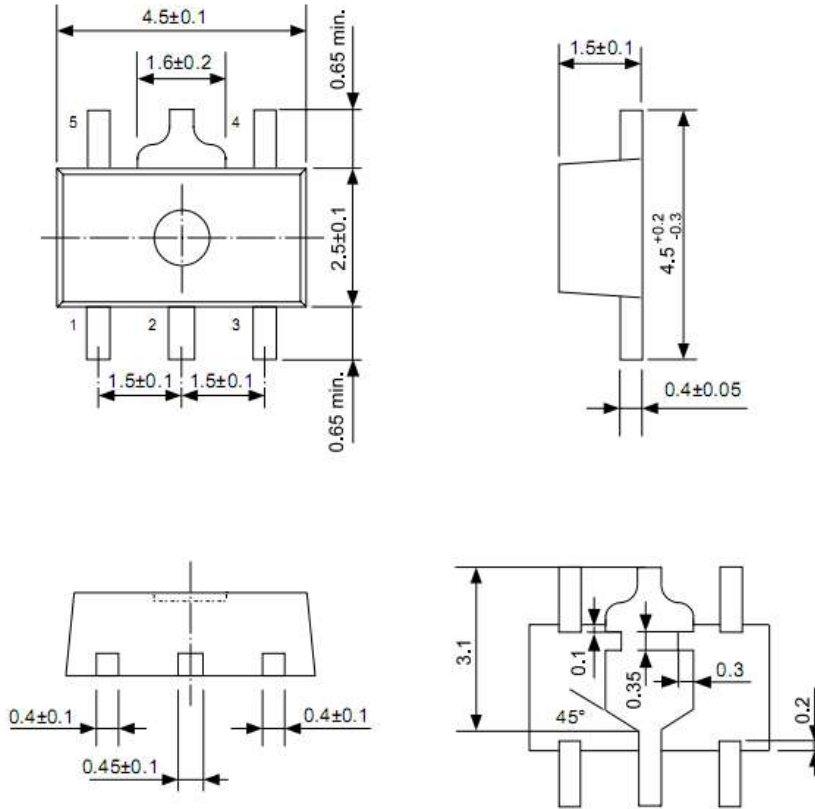

SOT23-5

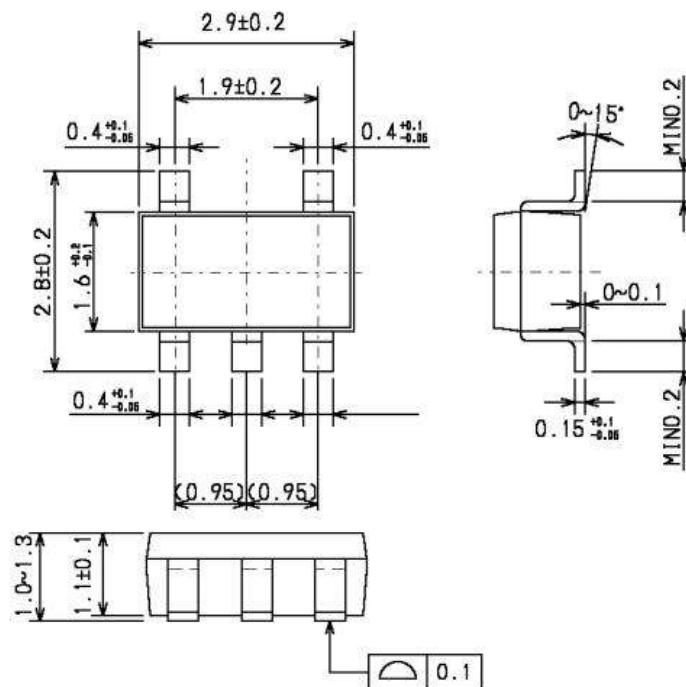

SOT89-3

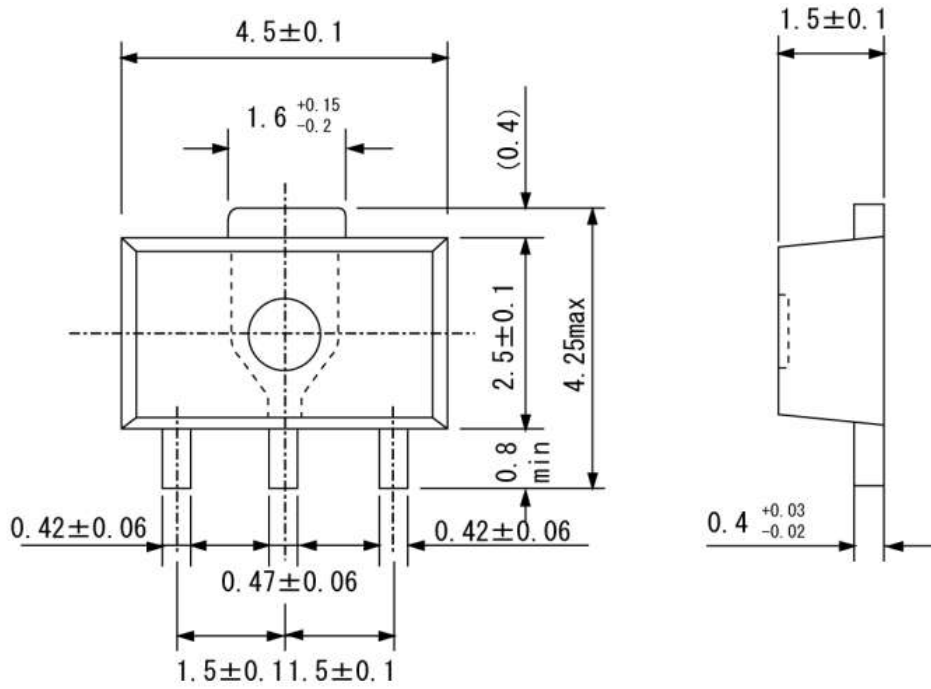

- The information described herein is subject to change without notice.
- Nanjing Micro One Electronics Inc is not responsible for any problems caused by circuits or diagrams described herein whose related industrial properties, patents, or other rights belong to third parties. The application circuit examples explain typical applications of the products, and do not guarantee the success of any specific mass-production design.
- Use of the information described herein for other purposes and/or reproduction or copying without the express permission of Nanjing Micro One Electronics Inc is strictly prohibited.
- The products described herein cannot be used as part of any device or equipment affecting the human body, such as exercise equipment, medical equipment, security systems, gas equipment, or any apparatus installed in airplanes and other vehicles, without prior written permission of Nanjing Micro One Electronics Inc.
- Although Nanjing Micro One Electronics Inc exerts the greatest possible effort to ensure high quality and reliability, the failure or malfunction of semiconductor products may occur. The user of these products should therefore give thorough consideration to safety design, including redundancy, fire-prevention measures, and malfunction prevention, to prevent any accidents, fires, or community damage that may ensue.

X-ON Electronics

Largest Supplier of Electrical and Electronic Components

Click to view similar products for [LDO Voltage Regulators](#) category:

Click to view products by [Micro One](#) manufacturer:

Other Similar products are found below :

[M38D29FFHP#U1](#) [702103A](#) [717726C](#) [742457H](#) [MP20051DN-LF-Z](#) [R5F111PGGFB#30](#) [AP7363-SP-13](#) [NCP103AMX285TCG](#)
[NCV8664CST33T3G](#) [NCV8752AMX28TCG](#) [L9454](#) [AP7362-HA-7](#) [LX13043CLD](#) [TCR3DF185,LM\(CT](#) [TCR3DF24,LM\(CT](#)
[TCR3DF285,LM\(CT](#) [TCR3DF31,LM\(CT](#) [TCR3DF45,LM\(CT](#) [TLF4949EJ](#) [L9708](#) [L970813TR](#) [030014BB](#) [059985X](#) [EAN61387601](#)
[EAN61573601](#) [NCP121AMX173TCG](#) [NCP4687DH15T1G](#) [NCV8703MX30TCG](#) [701326R](#) [702087BB](#) [755078E](#) [TCR2EN28,LF\(S](#)
[LM1117DT-1.8/NO](#) [LT1086CM#TRPBF](#) [AZ1085S2-1.5TRE1](#) [MAX15101EWL+T](#) [NCV8170AXV250T2G](#) [SCD337BTG](#)
[TCR3DF27,LM\(CT](#) [TCR3DF19,LM\(CT](#) [TCR3DF125,LM\(CT](#) [TCR2EN18,LF\(S](#) [MAX15103EWL+T](#) [TS2937CZ-5.0 C0](#) [MAX8878EUK30-](#)
[T](#) [MAX663CPA](#) [NCV4269CPD50R2G](#) [NCV8716MT30TBG](#) [AZ1117IH-1.2TRG1](#) [MP2013GQ-P](#)