



High Speed LDO Regulators, High PSRR, Low noise, ME6511 Series

General Description

The ME6511 series are highly accurate, low noise, CMOS LDO Voltage Regulators. Offering low output noise, high ripple rejection ratio, low dropout and very fast turn-on times, the ME6511 series is ideal for today's cutting edge mobile phone. Internally the ME6511 includes a reference voltage source, error amplifiers, driver transistors, current limiters and phase compensators. The ME6511's current limiters' foldback circuit also operates as a short protect for the output current limiter and the output pin. The ME6511 series is also fully compatible with low ESR ceramic capacitors, reducing cost and improving output stability. This high level of output stability is maintained even during frequent load fluctuations, due to the excellent transient response performance and high PSRR achieved across a broad range of frequencies. The CE function allows the output of regulator to be turned off, resulting in greatly reduced power consumption.

Typical Application

- Mobile phones
- Cordless phones, radio communication equipment
- Portable games
- Cameras, Video cameras
- Reference voltage sources
- Battery powered equipment

Features

- Maximum Output Current: 500mA
($V_{IN}=4.3V, V_{OUT}=3.3V$)
- Dropout Voltage: 100mV@ $I_{OUT}=100mA$
- Operating Voltage Range: 1.2V~6.0V
- Highly Accuracy: $\pm 1\%$
- Low Power Consumption: 30uA (TYP.)
- Standby Current: 0.1uA (TYP.)
- High Ripple Rejection: 70dB@1KHz (ME6511C33)
- Low output noise: 50uVrms
- Line Regulation: 0.05% (TYP.)

Package

- 3-pin SOT89-3, SOT23-3
- 4-pin SOT343R, FBP1*1-4
- 5-pin SOT23-5, SOT353
- 6-pin DFN2*2-6

Typical Application Circuit

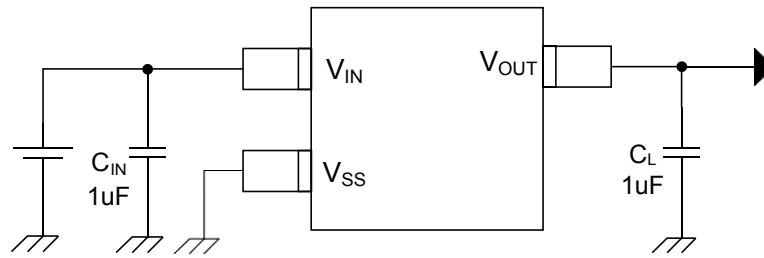

Fig1. ME6511A series

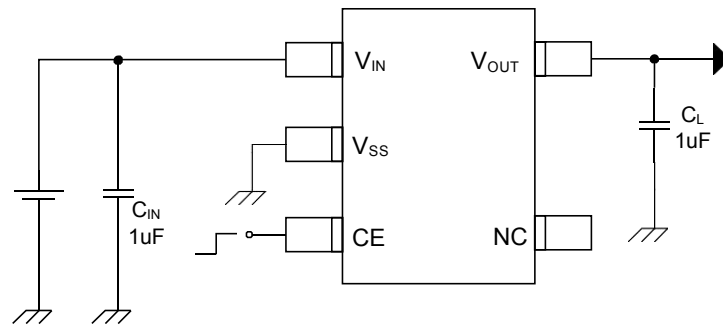

Fig2. ME6511C series

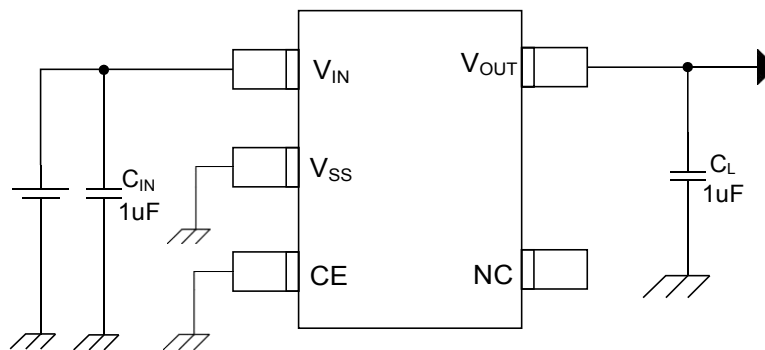
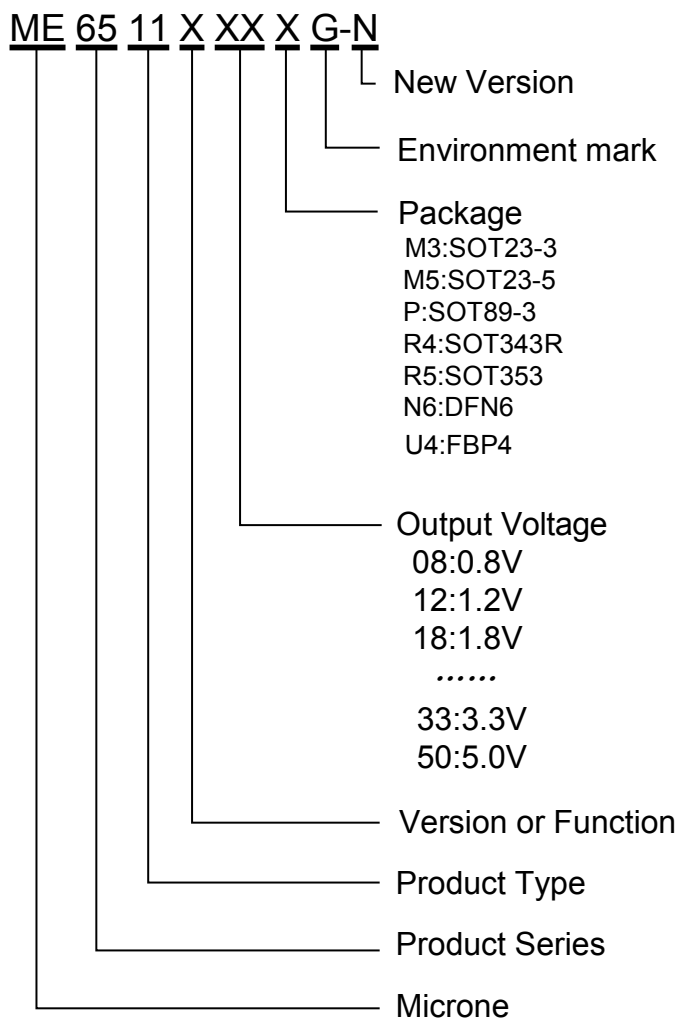

Fig3. ME6511H series

Selection Guide



product series	product function	Output voltage	Package
ME6511A12PG-N	Enable the internal connection of high	1.2V	SOT89-3
ME6511C33M5G-N	Enable can be set	3.3V	SOT23-5
ME6511C33R4G-N	Enable can be set	3.3V	SOT343R
ME6511C33U4AG-N	Enable can be set	3.3V	FBP1*1-4 (0.37)
ME6511C36U4AG-N	Enable can be set	3.6V	FBP1*1-4 (0.37)
ME6511C25N6AG-N	Enable can be set	2.5V	DFN2*2-6(0.75)
ME6511H15M5G-N	Enable connected to a low	1.5V	SOT23-5

NOTE: At present ,there are fourteen kinds of voltage value :

0.8V、1.0、1.2V、1.5V、1.8V、2.1V、2.5V、2.7V、2.8V、2.9V、3.0V、3.3V、3.6V、5.0V。

If you need other voltage and package, please contact our sales staff.

Pin Configuration

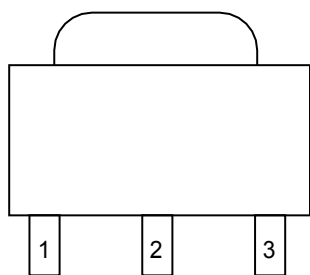

SOT89-3

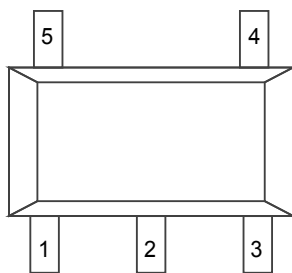

SOT23-5/SOT353

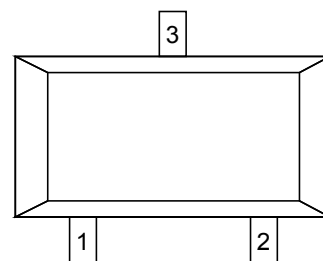

SOT23-3

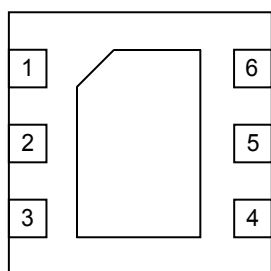

DFN2*2-6

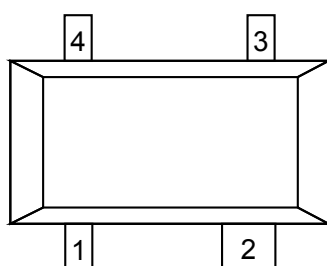

SOT343R

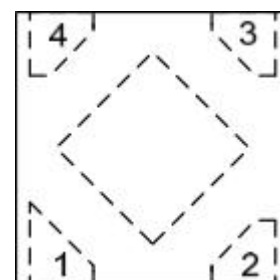



FBP1*1-4

Pin Assignment

ME6511AXXG

Pin Number			Pin Name	Functions
M3	P	P1		
SOT23-3	SOT89-3	SOT89-3		
1	1	2	V_{SS}	Ground
2	3	1	V_{OUT}	Output
3	2	3	V_{IN}	Power Input

The difference of printing on the chip between P and P1 is : P:  6211A , P1:  6211A1

ME6511AXXG-DS

Pin Number	Pin Name	Functions
SOT23-3		
1	V_{IN}	Power Input
2	V_{OUT}	Output
3	V_{SS}	Ground

ME6511CXXG/ ME6211HXXG

Pin Number				Pin Name	Functions
SOT23-5/SOT353	DFN2*2-6	SOT343R	FBP1*1-4		
1	3	4	4	V_{IN}	Power Input
2	2	2	2	V_{SS}	Ground
3	1	1	3	CE	ON / OFF Control
4	5,6	-	-	NC	No Connect
5	4	3	1	V_{OUT}	Output

Block Diagram

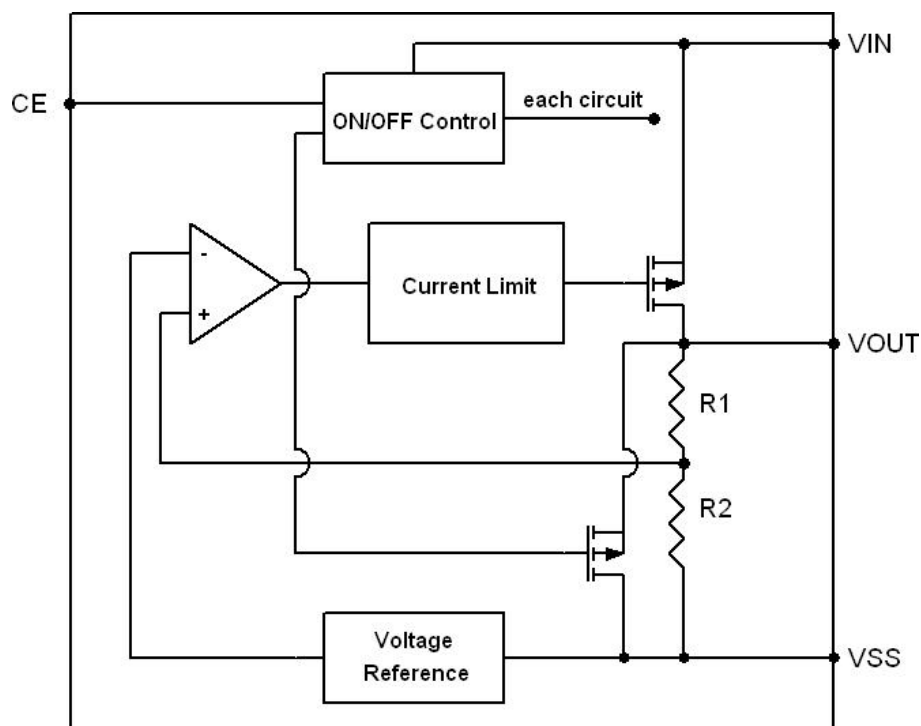

Absolute Maximum Ratings

Parameter	Symbol	Ratings	Units
Input Voltage	V_{IN}	6.5	V
Output Current	I_{OUT}	600	mA
Output Voltage	V_{OUT}	$V_{SS}-0.3 \sim V_{IN} + 0.3$	V
CE Pin Voltage	V_{CE}	$V_{SS}-0.3 \sim V_{IN} + 0.3$	V
Power Dissipation	P_D	SOT23-3	0.54
		SOT23-5	0.60
		SOT353	0.45
		DFN2*2-6	1.32
		SOT89-3	1.25
		SOT343R	0.45
		FBP1*1-4	0.5
Thermal resistance (Junction to air)	θ_{JA}	SOT23-3	230
		SOT23-5	210
		SOT353	270
		DFN2*2-6	95
		SOT89-3	100
		SOT343R	270
		FBP1*1-4	250
Operating Ambient Temperature Range	T_{OPR}	-40 ~ +85	$^{\circ}C$
Storage Temperature Range	T_{STG}	-55 ~ +150	$^{\circ}C$
Junction temperature	T_J	-40 ~ +150	$^{\circ}C$

Electrical Characteristics

ME6511C08 ($V_{IN} = V_{OUT} + 1V$, $V_{CE} = V_{IN}$, $C_{IN} = C_L = 1\mu F$, $T_a = 25^\circ C$, unless otherwise noted)

Parameter	Symbol	Conditions	Min.	Typ.	Max.	Units
Output Voltage	$V_{OUT(E)}$ (Note 2)	$I_{OUT} = 30mA$, $V_{IN} = V_{OUT} + 1V$	X 0.99	$V_{OUT(T)}$ (Note 1)	X 1.01	V
Maximum Output Current	I_{OUTMAX}	$V_{IN} = V_{OUT} + 1V$		250		mA
Load Regulation	ΔV_{OUT}	$V_{IN} = V_{OUT} + 1V$, $1mA \leq I_{OUT} \leq 100mA$		7		mV
Dropout Voltage (Note 3)	V_{DIF1}	$I_{OUT} = 100mA$		600		mV
	V_{DIF2}	$I_{OUT} = 200mA$		850		mV
Supply Current	I_{SS}	$V_{IN} = V_{OUT} + 1V$		30	60	μA
Stand-by Current	I_{CEL}	$V_{CE} = 0V$		0.1	1.0	μA
Line Regulation	$\frac{\Delta V_{OUT}}{\Delta V_{IN} \cdot V_{OUT}}$	$I_{OUT} = 30mA$ $V_{OUT} + 1V \leq V_{IN} \leq 6.5V$		0.05		%/V
CE "High" Voltage	VCEH	Start up	1.0			V
CE "Low" Voltage	VCEL	Shut down			0.5	V
Output noise	EN	$I_{OUT} = 40mA$, 300Hz~50kHz		50		μV_{rms}
Ripple Rejection Rate	PSRR	$V_{IN} = [V_{OUT} + 1]V + 1V_{p-pAC}$	$I_{OUT} = 10mA$, 1kHz	70		dB
			$I_{OUT} = 100mA$, 10kHz	62		

ME6511C10 ($V_{IN} = V_{OUT} + 1V$, $V_{CE} = V_{IN}$, $C_{IN} = C_L = 1\mu F$, $T_a = 25^\circ C$, unless otherwise noted)

Parameter	Symbol	Conditions	Min.	Typ.	Max.	Units
Output Voltage	$V_{OUT(E)}$ (Note 2)	$I_{OUT} = 30mA$, $V_{IN} = V_{OUT} + 1V$	X 0.99	$V_{OUT(T)}$ (Note 1)	X 1.01	V
Maximum Output Current	I_{OUTMAX}	$V_{IN} = V_{OUT} + 1V$		300		mA
Load Regulation	ΔV_{OUT}	$V_{IN} = V_{OUT} + 1V$, $1mA \leq I_{OUT} \leq 100mA$		5		mV
Dropout Voltage (Note 3)	V_{DIF1}	$I_{OUT} = 100mA$		400		mV
	V_{DIF2}	$I_{OUT} = 200mA$		650		mV
Supply Current	I_{SS}	$V_{IN} = V_{OUT} + 1V$		30	60	μA
Stand-by Current	I_{CEL}	$V_{CE} = 0V$		0.1	1.0	μA
Line Regulation	$\frac{\Delta V_{OUT}}{\Delta V_{IN} \cdot V_{OUT}}$	$I_{OUT} = 30mA$ $V_{OUT} + 1V \leq V_{IN} \leq 6.5V$		0.035		%/V
CE "High" Voltage	VCEH	Start up	1.0			V
CE "Low" Voltage	VCEL	Shut down			0.5	V
Output noise	EN	$I_{OUT} = 40mA$, 300Hz~50kHz		50		μV_{rms}
Ripple Rejection Rate	PSRR	$V_{IN} = [V_{OUT} + 1]V + 1V_{p-pAC}$	$I_{OUT} = 10mA$, 1kHz	70		dB
			$I_{OUT} = 100mA$, 10kHz	62		

ME6511C12 ($V_{IN} = V_{OUT} + 1V$, $V_{CE} = V_{IN}$, $C_{IN} = C_L = 1\mu F$, $T_a = 25^\circ C$, unless otherwise noted)

Parameter	Symbol	Conditions	Min.	Typ.	Max.	Units
Output Voltage	$V_{OUT(E)}$ (Note 2)	$I_{OUT} = 30mA$, $V_{IN} = V_{OUT} + 1V$	X 0.99	$V_{OUT(T)}$ (Note 1)	X 1.01	V
Maximum Output Current	I_{OUTMAX}	$V_{IN} = V_{OUT} + 1V$		300		mA
Load Regulation	ΔV_{OUT}	$V_{IN} = V_{OUT} + 1V$, $1mA \leq I_{OUT} \leq 100mA$		8		mV
Dropout Voltage (Note 3)	V_{DIF1}	$I_{OUT} = 100mA$		280		mV
	V_{DIF2}	$I_{OUT} = 200mA$		500		mV
Supply Current	I_{SS}	$V_{IN} = V_{OUT} + 1V$		30	60	μA
Stand-by Current	I_{CEL}	$V_{CE} = 0V$		0.1	1.0	μA
Line Regulation	$\frac{\Delta V_{OUT}}{\Delta V_{IN} \cdot V_{OUT}}$	$I_{OUT} = 30mA$ $V_{OUT} + 1V \leq V_{IN} \leq 6.5V$		0.03		%/V
CE "High" Voltage	VCEH	Start up	1.0			V
CE "Low" Voltage	VCEL	Shut down			0.5	V
Output noise	EN	$I_{OUT} = 40mA$, 300Hz~50kHz		50		μV_{rms}
Ripple Rejection Rate	PSRR	$V_{IN} = [V_{OUT} + 1]V$ +1Vp-pAC	$I_{OUT} = 10mA$, 1kHz	70		dB
			$I_{OUT} = 100mA$, 10kHz	62		

ME6511C15 ($V_{IN} = V_{OUT} + 1V$, $V_{CE} = V_{IN}$, $C_{IN} = C_L = 1\mu F$, unless otherwise noted)

Parameter	Symbol	Conditions	Min.	Typ.	Max.	Units
Output Voltage	$V_{OUT(E)}$ (Note 2)	$I_{OUT} = 30mA$, $V_{IN} = V_{OUT} + 1V$	X 0.99	$V_{OUT(T)}$ (Note 1)	X 1.01	V
Maximum Output Current	I_{OUTMAX}	$V_{IN} = V_{OUT} + 1V$		300		mA
Load Regulation	ΔV_{OUT}	$V_{IN} = V_{OUT} + 1V$, $1mA \leq I_{OUT} \leq 100mA$		9		mV
Dropout Voltage (Note 3)	V_{DIF1}	$I_{OUT} = 100mA$		200		mV
	V_{DIF2}	$I_{OUT} = 200mA$		400		mV
Supply Current	I_{SS}	$V_{IN} = V_{OUT} + 1V$		30	60	μA
Stand-by Current	I_{CEL}	$V_{CE} = 0V$		0.1	1.0	μA
Line Regulation	$\frac{\Delta V_{OUT}}{\Delta V_{IN} \cdot V_{OUT}}$	$I_{OUT} = 30mA$ $V_{OUT} + 1V \leq V_{IN} \leq 6.5V$		0.05		%/V
CE "High" Voltage	VCEH	Shut up	1.0			V
CE "Low" Voltage	VCEL	Start down			0.5	V
Output noise	EN	$I_{OUT} = 40mA$, 300Hz~50kHz		50		μV_{rms}
Ripple Rejection Rate	PSRR	$V_{IN} = [V_{OUT} + 1]V + 1Vp-pAC$	$I_{OUT} = 10mA$, 1kHz	70		dB
			$I_{OUT} = 100mA$, 10kHz	62		

ME6511C18 ($V_{IN} = V_{OUT} + 1V$, $V_{CE} = V_{IN}$, $C_{IN} = C_L = 1\mu F$, $T_a = 25^\circ C$, unless otherwise noted)

Parameter	Symbol	Conditions	Min.	Typ.	Max.	Units
Output Voltage	$V_{OUT(E)}$ (Note 2)	$I_{OUT} = 30mA$, $V_{IN} = V_{OUT} + 1V$	X 0.99	$V_{OUT(T)}$ (Note 1)	X 1.01	V
Maximum Output Current	I_{OUTMAX}	$V_{IN} = V_{OUT} + 1V$		300		mA
Load Regulation	ΔV_{OUT}	$V_{IN} = V_{OUT} + 1V$, $1mA \leq I_{OUT} \leq 100mA$		9		mV
Dropout Voltage (Note 3)	V_{DIF1}	$I_{OUT} = 100mA$		200		mV
	V_{DIF2}	$I_{OUT} = 200mA$		400		mV
Supply Current	I_{SS}	$V_{IN} = V_{OUT} + 1V$		30	60	μA
Stand-by Current	I_{CEL}	$V_{CE} = 0V$		0.1	1.0	μA
Line Regulation	$\frac{\Delta V_{OUT}}{\Delta V_{IN} \cdot V_{OUT}}$	$I_{OUT} = 30mA$ $V_{OUT} + 1V \leq V_{IN} \leq 6.5V$		0.05		%/V
CE "High" Voltage	VCEH	Start up	1.0			V
CE "Low" Voltage	VCEL	Shut down			0.5	V
Output noise	EN	$I_{OUT} = 40mA$, 300Hz~50kHz		50		μV_{rms}
Ripple Rejection Rate	PSRR	$V_{IN} = [V_{OUT} + 1]V + 1V_{p-pAC}$	$I_{OUT} = 10mA$, 1kHz	70		dB
			$I_{OUT} = 100mA$, 10kHz	62		

ME6511C25 ($V_{IN} = V_{OUT} + 1V$, $V_{CE} = V_{IN}$, $C_{IN} = C_L = 1\mu F$, $T_a = 25^\circ C$, unless otherwise noted)

Parameter	Symbol	Conditions	Min.	Typ.	Max.	Units
Output Voltage	$V_{OUT(E)}$ (Note 2)	$I_{OUT} = 30mA$, $V_{IN} = V_{OUT} + 1V$	X 0.99	$V_{OUT(T)}$ (Note 1)	X1.01	V
Maximum Output Current	I_{OUTMAX}	$V_{IN} = V_{OUT} + 1V$		400		mA
Load Regulation	ΔV_{OUT}	$V_{IN} = V_{OUT} + 1V$, $1mA \leq I_{OUT} \leq 100mA$		9		mV
Dropout Voltage (Note 3)	V_{DIF1}	$I_{OUT} = 100mA$		110		mV
	V_{DIF2}	$I_{OUT} = 200mA$		220		mV
Supply Current	I_{SS}	$V_{IN} = V_{OUT} + 1V$		30	60	μA
Stand-by Current	I_{CEL}	$V_{CE} = 0V$		0.1	1.0	μA
Line Regulation	$\frac{\Delta V_{OUT}}{\Delta V_{IN} \cdot V_{OUT}}$	$I_{OUT} = 30mA$ $V_{OUT} + 1V \leq V_{IN} \leq 6.5V$		0.04		%/V
CE "High" Voltage	VCEH	Start up	1.0			V
CE "Low" Voltage	VCEL	Shut down			0.5	V
Output noise	EN	$I_{OUT} = 40mA$, 300Hz~50kHz		50		μV_{rms}
Ripple Rejection Rate	PSRR	$V_{IN} = [V_{OUT} + 1]V + 1V_{p-pAC}$	$I_{OUT} = 10mA$, 1kHz	70		dB
			$I_{OUT} = 100mA$, 10kHz	62		
			$I_{OUT} = 200mA$, 10kHz	62		
Short-circuit Current	I_{SHORT}	$V_{IN} = V_{OUT} + 1V$, $V_{CE} = V_{IN}$, $V_{OUT} = 0V$		60		mA

ME6511C28 ($V_{IN} = V_{OUT} + 1V$, $V_{CE} = V_{IN}$, $C_{IN} = C_L = 1\mu F$, $T_a = 25^\circ C$, unless otherwise noted)

Parameter	Symbol	Conditions	Min.	Typ.	Max.	Units
Output Voltage	$V_{OUT(E)}$ (Note 2)	$I_{OUT} = 30mA$, $V_{IN} = V_{OUT} + 1V$	X 0.99	$V_{OUT(T)}$ (Note 1)	X1.01	V
Maximum Output Current	I_{OUTMAX}	$V_{IN} = V_{OUT} + 1V$		450		mA
Load Regulation	ΔV_{OUT}	$V_{IN} = V_{OUT} + 1V$, $1mA \leq I_{OUT} \leq 100mA$		7		mV
Dropout Voltage (Note 3)	V_{DIF1}	$I_{OUT} = 100mA$		110		mV
	V_{DIF2}	$I_{OUT} = 200mA$		220		mV
Supply Current	I_{SS}	$V_{IN} = V_{OUT} + 1V$		30	60	μA
Stand-by Current	I_{CEL}	$V_{CE} = 0V$		0.1	1.0	μA
Line Regulation	$\frac{\Delta V_{OUT}}{\Delta V_{IN} \cdot V_{OUT}}$	$I_{OUT} = 30mA$ $V_{OUT} + 1V \leq V_{IN} \leq 6.5V$		0.04		%/V
CE "High" Voltage	VCEH	Start up	1.0			V
CE "Low" Voltage	VCEL	Shut down			0.5	V
Output noise	EN	$I_{OUT} = 40mA$, 300Hz~50kHz		50		μV_{rms}
Ripple Rejection Rate	PSRR	$V_{IN} = [V_{OUT} + 1]V + 1V_{p-pAC}$	$I_{OUT} = 10mA, 1kHz$		70	dB
			$I_{OUT} = 100mA, 10kHz$		62	
			$I_{OUT} = 200mA, 10kHz$		62	
Short-circuit Current	I_{SHORT}	$V_{IN} = V_{OUT} + 1V$, $V_{CE} = V_{IN}$, $V_{OUT} = 0V$		65		mA

ME6511C30 ($V_{IN} = V_{OUT} + 1V$, $V_{CE} = V_{IN}$, $C_{IN} = C_L = 1\mu F$, $T_a = 25^\circ C$, unless otherwise noted)

Parameter	Symbol	Conditions	Min.	Typ.	Max.	Units
Output Voltage	$V_{OUT(E)}$ (Note 2)	$I_{OUT} = 30mA$, $V_{IN} = V_{OUT} + 1V$	X 0.99	$V_{OUT(T)}$ (Note 1)	X 1.01	V
Maximum Output Current	I_{OUTMAX}	$V_{IN} = V_{OUT} + 1V$		500		mA
Load Regulation	ΔV_{OUT}	$V_{IN} = V_{OUT} + 1V$, $1mA \leq I_{OUT} \leq 100mA$		8		mV
Dropout Voltage (Note 3)	V_{DIF1}	$I_{OUT} = 100mA$		100		mV
	V_{DIF2}	$I_{OUT} = 200mA$		210		mV
Supply Current	I_{SS}	$V_{IN} = V_{OUT} + 1V$		30	60	μA
Stand-by Current	I_{CEL}	$V_{CE} = 0V$		0.1	1.0	μA
Line Regulation	$\frac{\Delta V_{OUT}}{\Delta V_{IN} \cdot V_{OUT}}$	$I_{OUT} = 30mA$ $V_{OUT} + 1V \leq V_{IN} \leq 6.5V$		0.05		%/V
CE "High" Voltage	VCEH	Start up	1.0			V
CE "Low" Voltage	VCEL	Shut down			0.5	V
Output noise	EN	$I_{OUT} = 40mA$, 300Hz~50kHz		50		μV_{rms}
Ripple Rejection Rate	PSRR	$V_{IN} = [V_{OUT} + 1]V + 1V_{p-pAC}$	$I_{OUT} = 10mA, 1kHz$		70	dB
			$I_{OUT} = 100mA, 10kHz$		62	
			$I_{OUT} = 200mA, 10kHz$		62	
Short-circuit Current	I_{SHORT}	$V_{IN} = V_{OUT} + 1V$, $V_{CE} = V_{IN}$, $V_{OU} = 0V$		65		mA

ME6511C33 ($V_{IN}=V_{OUT}+1V$, $V_{CE}=V_{IN}$, $C_{IN}=C_L=1\mu F$, $T_a=25^\circ C$, unless otherwise noted)

Parameter	Symbol	Conditions	Min.	Typ.	Max.	Units
Output Voltage	$V_{OUT(E)}$ (Note 2)	$I_{OUT}=30mA$, $V_{IN}=V_{OUT}+1V$	X 0.99	$V_{OUT(T)}$ (Note 1)	X 1.01	V
Maximum Output Current	I_{OUTMAX}	$V_{IN}=V_{OUT}+1V$		500		mA
Load Regulation	ΔV_{OUT}	$V_{IN}=V_{OUT}+1V$, $1mA \leq I_{OUT} \leq 100mA$		9		mV
Dropout Voltage (Note 3)	V_{DIF1}	$I_{OUT}=100mA$		120		mV
	V_{DIF2}	$I_{OUT}=200mA$		260		mV
Supply Current	I_{SS}	$V_{IN}=V_{OUT}+1V$		30	60	μA
Stand-byCurrent	I_{CEL}	$V_{CE}=0V$		0.1	1.0	μA
Line Regulation	$\frac{\Delta V_{OUT}}{\Delta V_{IN} \cdot V_{OUT}}$	$I_{OUT}=30mA$ $V_{OUT}+1V \leq V_{IN} \leq 6.5V$		0.05		%/V
CE "High" Voltage	VCEH	Start up	1.0			V
CE "Low" Voltage	VCEL	Shut down			0.5	V
Output noise	EN	$I_{OUT}=40mA$, 300Hz~50kHz		50		μV_{rms}
Ripple Rejection Rate	PSRR	$V_{IN} = [V_{OUT} + 1]V$ $+1V_{p-pAC}$	$I_{OUT}=10mA, 1kHz$	70		dB
			$I_{OUT}=100mA, 10kHz$	62		
			$I_{OUT}=200mA, 10kHz$	62		
Short-circuit Current	I_{SHORT}	$V_{IN}=V_{OUT}+1V$, $V_{CE}=V_{IN}$, $V_{OUT}=0V$		70		mA

ME6511C33 (SOT343R, FBP1*1-4L, SOT353)

($V_{IN}=V_{OUT}+1V$, $V_{CE}=V_{IN}$, $C_{IN}=C_L=1\mu F$, $T_a=25^\circ C$, unless otherwise noted)

Parameter	Symbol	Conditions	Min.	Typ.	Max.	Units
Output Voltage	$V_{OUT(E)}$ (Note 2)	$I_{OUT}=30mA$, $V_{IN}=V_{OUT}+1V$	X 0.99	$V_{OUT(T)}$ (Note 1)	X 1.01	V
Maximum Output Current	I_{OUTMAX}	$V_{IN}=V_{OUT}+1V$		400		mA
Load Regulation	ΔV_{OUT}	$V_{IN}=V_{OUT}+1V$, $1mA \leq I_{OUT} \leq 100mA$		9		mV
Dropout Voltage (Note 3)	V_{DIF1}	$I_{OUT}=100mA$		120		mV
	V_{DIF2}	$I_{OUT}=200mA$		260		mV
Supply Current	I_{SS}	$V_{IN}=V_{OUT}+1V$		30	60	μA
Stand-byCurrent	I_{CEL}	$V_{CE}=0V$		0.1	1.0	μA
Line Regulation	$\frac{\Delta V_{OUT}}{\Delta V_{IN} \cdot V_{OUT}}$	$I_{OUT}=30mA$ $V_{OUT}+1V \leq V_{IN} \leq 6.5V$		0.05		%/V
CE "High" Voltage	VCEH	Start up	1.0			V
CE "Low" Voltage	VCEL	Shut down			0.5	V
Output noise	EN	$I_{OUT}=40mA$, 300Hz~50kHz		50		μV_{rms}
Ripple Rejection Rate	PSRR	$V_{IN} = [V_{OUT} + 1]V$ $+1V_{p-pAC}$	$I_{OUT}=10mA, 1kHz$	70		dB
			$I_{OUT}=100mA, 10kHz$	62		
			$I_{OUT}=200mA, 10kHz$	62		
Short-circuit Current	I_{SHORT}	$V_{IN}=V_{OUT}+1V$, $V_{CE}=V_{IN}$, $V_{OUT}=0V$		70		mA

ME6511C36 ($V_{IN} = V_{OUT} + 1V$, $V_{CE} = V_{IN}$, $C_{IN} = C_L = 1\mu F$, $T_a = 25^\circ C$, unless otherwise noted)

Parameter	Symbol	Conditions	Min.	Typ.	Max.	Units
Output Voltage	$V_{OUT(E)}$ (Note 2)	$I_{OUT} = 30mA$, $V_{IN} = V_{OUT} + 1V$	X 0.99	$V_{OUT(T)}$ (Note 1)	X 1.01	V
Maximum Output Current	I_{OUTMAX}	$V_{IN} = V_{OUT} + 1V$		400		mA
Load Regulation	ΔV_{OUT}	$V_{IN} = V_{OUT} + 1V$, $1mA \leq I_{OUT} \leq 100mA$		8		mV
Dropout Voltage (Note 3)	V_{DIF1}	$I_{OUT} = 100mA$		100		mV
	V_{DIF2}	$I_{OUT} = 200mA$		200		mV
Supply Current	I_{SS}	$V_{IN} = V_{OUT} + 1V$		40	60	μA
Stand-by Current	I_{CEL}	$V_{CE} = 0V$		0.1	1.0	μA
Line Regulation	$\frac{\Delta V_{OUT}}{\Delta V_{IN} \cdot V_{OUT}}$	$I_{OUT} = 30mA$ $V_{OUT} + 1V \leq V_{IN} \leq 6.5V$		0.05		%/V
CE "High" Voltage	VCEH	Start up	1.0			V
CE "Low" Voltage	VCEL	Shut down			0.5	V
Output noise	EN	$I_{OUT} = 40mA$, 300Hz~50kHz		50		μV_{rms}
Ripple Rejection Rate	PSRR	$V_{IN} = [V_{OUT} + 1]V$ $+ 1V_{p-pAC}$	$I_{OUT} = 10mA, 1kHz$	70		dB
			$I_{OUT} = 100mA, 10kHz$	62		
			$I_{OUT} = 200mA, 10kHz$	62		
Short-circuit Current	I_{SHORT}	$V_{IN} = V_{OUT} + 1V$, $V_{CE} = V_{IN}$, $V_{OUT} = 0V$		100		mA

ME6511C50 ($V_{IN} = V_{OUT} + 1V$, $V_{CE} = V_{IN}$, $C_{IN} = C_L = 1\mu F$, $T_a = 25^\circ C$, unless otherwise noted)

Parameter	Symbol	Conditions	Min.	Typ.	Max.	Units
Output Voltage	$V_{OUT(E)}$ (Note 2)	$I_{OUT} = 30mA$, $V_{IN} = V_{OUT} + 1V$	X 0.99	$V_{OUT(T)}$ (Note 1)	X 1.01	V
Maximum Output Current	I_{OUTMAX}	$V_{IN} = V_{OUT} + 1V$		500		mA
Load Regulation	ΔV_{OUT}	$V_{IN} = V_{OUT} + 1V$, $1mA \leq I_{OUT} \leq 100mA$		8		mV
Dropout Voltage (Note 3)	V_{DIF1}	$I_{OUT} = 100mA$		100		mV
	V_{DIF2}	$I_{OUT} = 200mA$		200		mV
Supply Current	I_{SS}	$V_{IN} = V_{OUT} + 1V$		40	60	μA
Stand-by Current	I_{CEL}	$V_{CE} = 0V$		0.1	1.0	μA
Line Regulation	$\frac{\Delta V_{OUT}}{\Delta V_{IN} \cdot V_{OUT}}$	$I_{OUT} = 30mA$ $V_{OUT} + 1V \leq V_{IN} \leq 6.5V$		0.05		%/V
CE "High" Voltage	VCEH	Start up	1.0			V
CE "Low" Voltage	VCEL	Shut down			0.7	V
Output noise	EN	$I_{OUT} = 40mA$, 300Hz~50kHz		50		μV_{rms}
Ripple Rejection Rate	PSRR	$V_{IN} = [V_{OUT} + 1]V$, $I_{OUT} = 10mA, 1kHz$		70		dB

		+1]V +1Vp-pAC	I _{OUT} =100mA, 10kHz		62	
			I _{OUT} =200mA, 10kHz		62	
Short-circuit Current	I _{SHORT}	V _{IN} = V _{OUT} +1V, V _{CE} = V _{IN} , V _{OUT} = 0V			100	mA

ME6511A30 (V_{IN} = V_{OUT}+1V, C_{IN}=C_L=1uF, Ta=25°C, unless otherwise noted)

Parameter	Symbol	Conditions	Min.	Typ.	Max.	Units
Output Voltage	V _{OUT} (E) (Note 2)	I _{OUT} =30mA, V _{IN} = V _{OUT} +1V	X 0.99	V _{OUT} (T) (Note 1)	X 1.01	V
Maximum Output Current	I _{OUTMAX}	V _{IN} = V _{OUT} +1V		500		mA
Load Regulation	ΔV _{OUT}	V _{IN} = V _{OUT} +1V , 1mA ≤ I _{OUT} ≤ 100mA		8		mV
Dropout Voltage (Note 3)	V _{DIF1}	I _{OUT} = 100mA		100		mV
	V _{DIF2}	I _{OUT} = 200mA		210		mV
Supply Current	I _{SS}	V _{IN} = V _{OUT} +1V		30	60	μA
Line Regulation	$\frac{\Delta V_{OUT}}{\Delta V_{IN} \cdot V_{OUT}}$	I _{OUT} = 30mA V _{OUT} +1V ≤ V _{IN} ≤ 6.5V		0.05		%/V
Output noise	EN	I _{OUT} = 40mA, 300Hz~50kHz		50		uVrms
Ripple Rejection Rate	PSRR	V _{IN} = [V _{OUT} +1]V +1Vp-pAC	I _{OUT} =10mA, 1kHz		70	dB
			I _{OUT} =100mA, 10kHz		62	
			I _{OUT} =200mA, 10kHz		62	
Short-circuit Current	I _{SHORT}	V _{IN} = V _{OUT} +1V, V _{CE} = V _{IN} , V _{OUT} = 0V			65	mA

ME6511A33 (V_{IN} = V_{OUT}+1V, C_{IN}=C_L=1uF, Ta=25°C, unless otherwise noted)

Parameter	Symbol	Conditions	Min.	Typ.	Max.	Units
Output Voltage	V _{OUT} (E) (Note 2)	I _{OUT} =30mA, V _{IN} = V _{OUT} +1V	X 0.99	V _{OUT} (T) (Note 1)	X 1.01	V
Maximum Output Current	I _{OUTMAX}	V _{IN} = V _{OUT} +1V		500		mA
Load Regulation	ΔV _{OUT}	V _{IN} = V _{OUT} +1V , 1mA ≤ I _{OUT} ≤ 100mA		9		mV
Dropout Voltage (Note 3)	V _{DIF1}	I _{OUT} = 100mA		120		mV
	V _{DIF2}	I _{OUT} = 200mA		260		mV
Supply Current	I _{SS}	V _{IN} = V _{OUT} +1V		30	60	μA
Line Regulation	$\frac{\Delta V_{OUT}}{\Delta V_{IN} \cdot V_{OUT}}$	I _{OUT} = 30mA V _{OUT} +1V ≤ V _{IN} ≤ 6.5V		0.1	1.0	%/V
Output noise	EN	I _{OUT} = 40mA, 300Hz~50kHz		50		uVrms
Ripple Rejection Rate	PSRR	V _{IN} = [V _{OUT} +1]V +1Vp-pAC	I _{OUT} =10mA, 1kHz		70	dB
			I _{OUT} =100mA, 10kHz		62	
			I _{OUT} =200mA, 10kHz		62	
Short-circuit Current	I _{SHORT}	V _{IN} = V _{OUT} +1V, V _{OUT} = 0V			70	mA

ME6511A25 ($V_{IN} = V_{OUT} + 1V$, $C_{IN} = C_L = 1\mu F$, $T_a = 25^\circ C$, unless otherwise noted)

Parameter	Symbol	Conditions	Min.	Typ.	Max.	Units
Output Voltage	$V_{OUT(E)}$ (Note 2)	$I_{OUT} = 30mA$, $V_{IN} = V_{OUT} + 1V$	X 0.99	$V_{OUT(T)}$ (Note 1)	X 1.01	V
Maximum Output Current	I_{OUTMAX}	$V_{IN} = V_{OUT} + 1V$		400		mA
Load Regulation	ΔV_{OUT}	$V_{IN} = V_{OUT} + 1V$, $1mA \leq I_{OUT} \leq 100mA$		9		mV
Dropout Voltage (Note 3)	V_{DIF1}	$I_{OUT} = 100mA$		80		mV
	V_{DIF2}	$I_{OUT} = 200mA$		180		mV
Supply Current	I_{SS}	$V_{IN} = V_{OUT} + 1V$		30	60	μA
Line Regulation	$\frac{\Delta V_{OUT}}{\Delta V_{IN} \cdot V_{OUT}}$	$I_{OUT} = 30mA$ $V_{OUT} + 1V \leq V_{IN} \leq 6.5V$		0.1	1.0	%/V
Output noise	EN	$I_{OUT} = 40mA$, 300Hz~50kHz		50		μV_{rms}
Ripple Rejection Rate	PSRR	$V_{IN} = [V_{OUT} + 1]V$ $+1Vp-pAC$	$I_{OUT} = 10mA, 1kHz$		70	dB
			$I_{OUT} = 100mA, 10kHz$		62	
			$I_{OUT} = 200mA, 10kHz$		62	
Short-circuit Current	I_{SHORT}	$V_{IN} = V_{OUT} + 1V$, $V_{OUT} = 0V$		60		mA

ME6511H15 ($V_{IN} = V_{OUT} + 1V$, $V_{CE} = GND$, $C_{IN} = C_L = 1\mu F$, $T_a = 25^\circ C$, unless otherwise noted)

Parameter	Symbol	Conditions	Min.	Typ.	Max.	Units
Output Voltage	$V_{OUT(E)}$ (Note 2)	$I_{OUT} = 30mA$, $V_{IN} = V_{OUT} + 1V$	X 0.98	$V_{OUT(T)}$ (Note 1)	X 1.02	V
Maximum Output Current	I_{OUTMAX}	$V_{IN} = V_{OUT} + 1V$		300		mA
Load Regulation	ΔV_{OUT}	$V_{IN} = V_{OUT} + 1V$, $1mA \leq I_{OUT} \leq 100mA$		9		mV
Dropout Voltage (Note 3)	V_{DIF1}	$I_{OUT} = 100mA$		200		mV
	V_{DIF2}	$I_{OUT} = 200mA$		400		mV
Supply Current	I_{SS}	$V_{IN} = V_{OUT} + 1V$		30	60	μA
Stand-by Current	I_{CEL}	$V_{CE} = V_{IN}$		0.1	1.0	μA
Line Regulation	$\frac{\Delta V_{OUT}}{\Delta V_{IN} \cdot V_{OUT}}$	$I_{OUT} = 30mA$ $V_{OUT} + 1V \leq V_{IN} \leq 6.5V$		0.05		%/V
CE "High" Voltage	VCEH	Shut down	1.0			V
CE "Low" Voltage	VCEL	Start up			0.4	V
Output noise	EN	$I_{OUT} = 40mA$, 300Hz~50kHz		50		μV_{rms}
Ripple Rejection Rate	PSRR	$V_{IN} = [V_{OUT} + 1]V + 1Vp-pAC$	$I_{OUT} = 10mA, 1kHz$		70	dB

Note :

- $V_{OUT(T)}$: Specified Output Voltage
- $V_{OUT(E)}$: Effective Output Voltage (i.e. The output voltage when " $V_{OUT(T)} + 1.0V$ " is provided at the V_{in} pin while maintaining a certain I_{out} value.)
- V_{DIF} : $V_{IN1} - V_{OUT(E)}$
 V_{IN1} : The input voltage when $V_{OUT(E)}$ appears as input voltage is gradually decreased.
 $V_{OUT(E)}$ = A voltage equal to 98% of the output voltage whenever an amply stabilized I_{out} ($V_{OUT(T)} + 1.0V$) is input.

Type Characteristics

(1) Output Current VS. Output Voltage ($V_{IN}=V_{out}+1$, $T_a = 25^\circ C$)

ME6511C33M5G

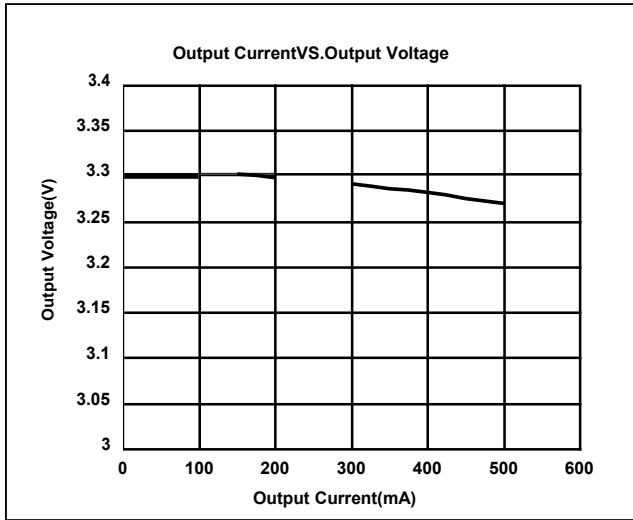

ME6511C30M5G

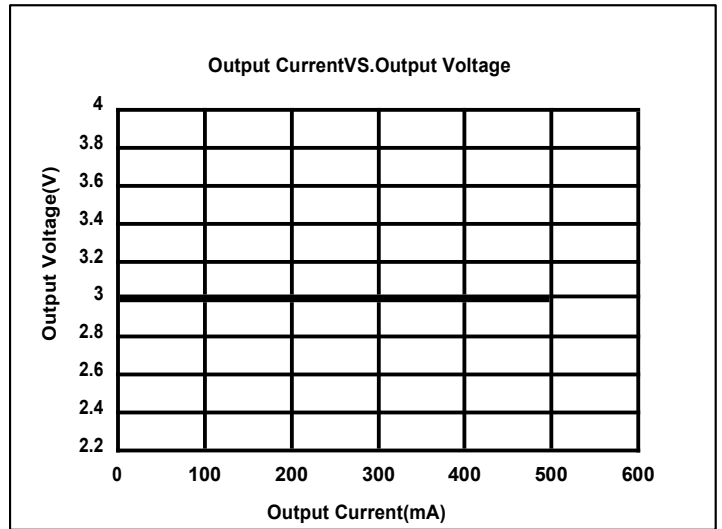

ME6511C28M5G

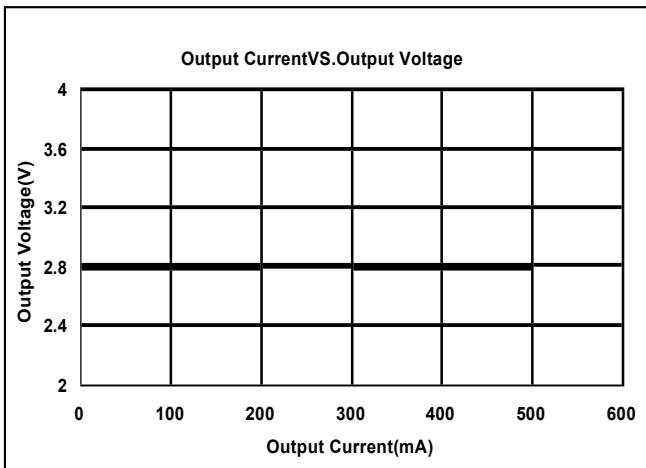

ME6511C18M5G

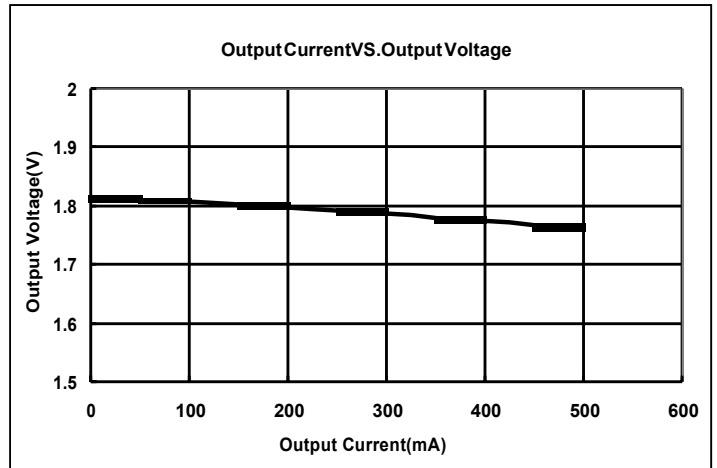

(2) Input Voltage VS. Output Voltage ($T_a = 25^\circ C$)

ME6511C33M5G

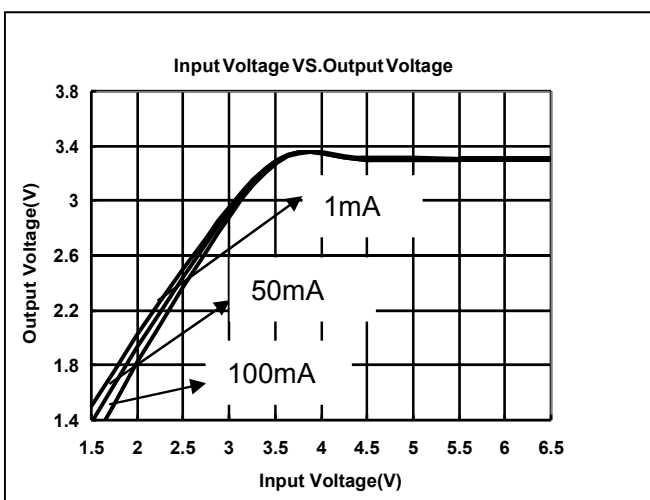

ME6511C30M5G

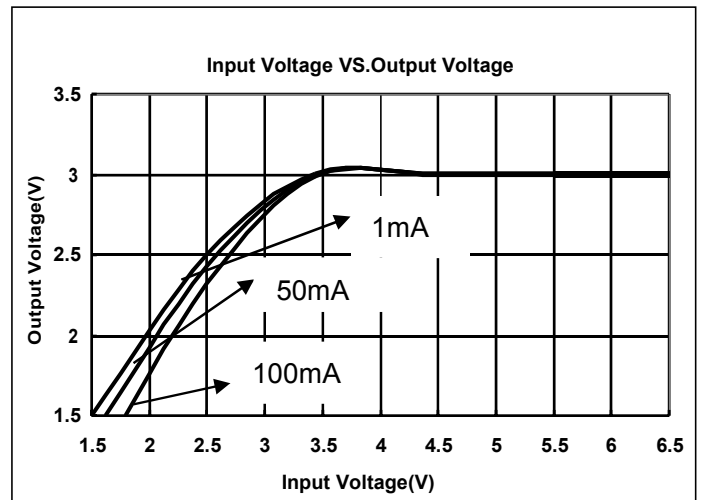

ME6511C28M5G

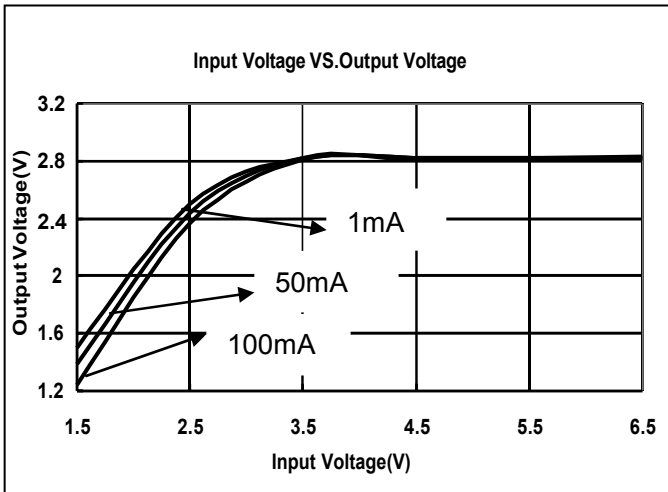

ME6511C18M5G

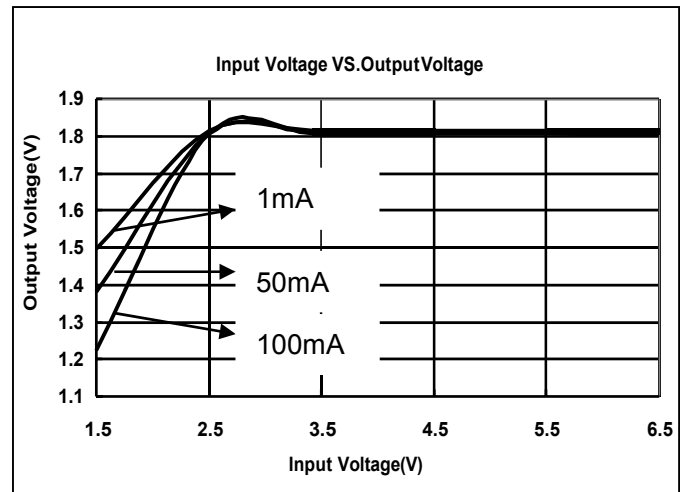

(3) Output Current VS. Dropout Voltage ($V_{IN}=V_{out}+1V, T_a = 25^\circ C$)

ME6511C33M5G

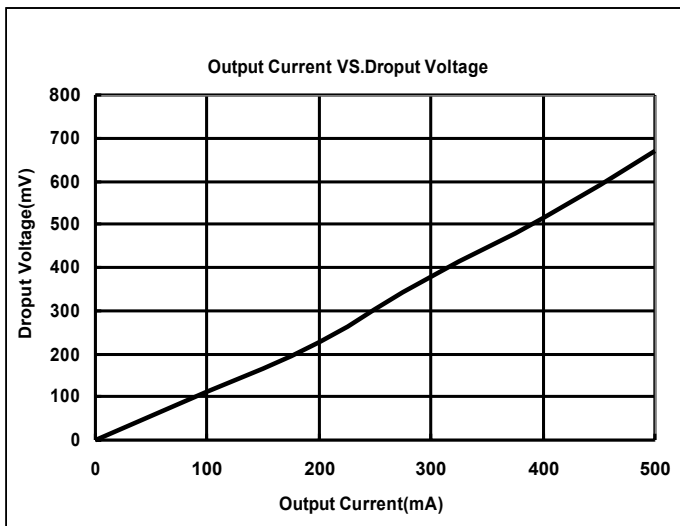

ME6511C30M5G

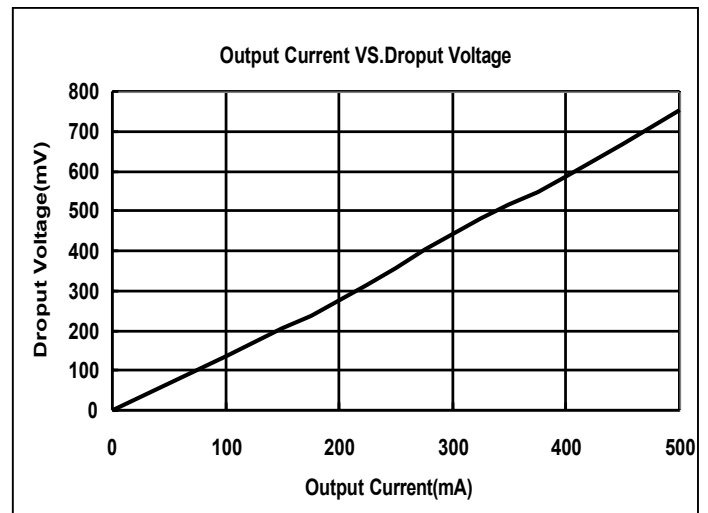

ME6511C28M5G

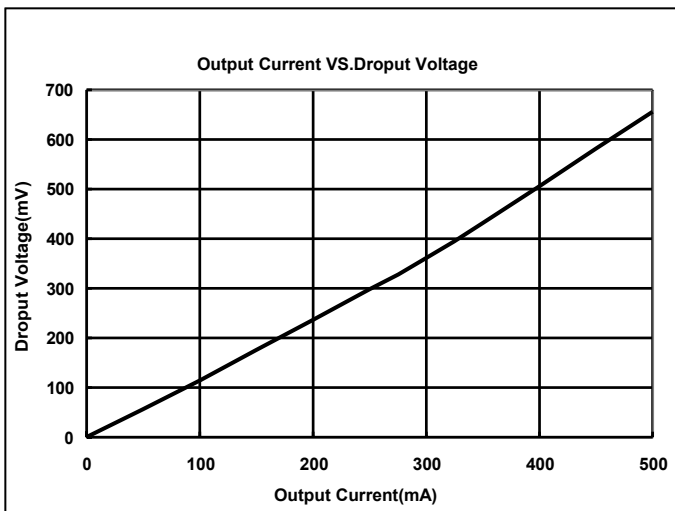

ME6511C18M5G

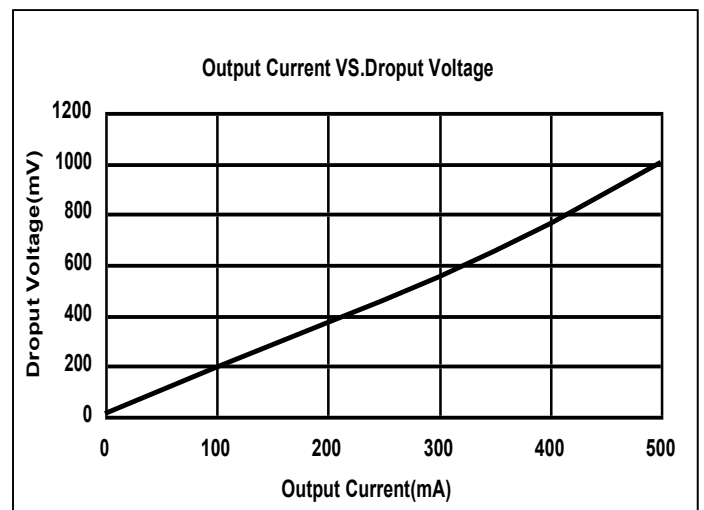

(4) Input Voltage VS. Supply Current ($T_a = 25^\circ\text{C}$)

ME6511C33M5G

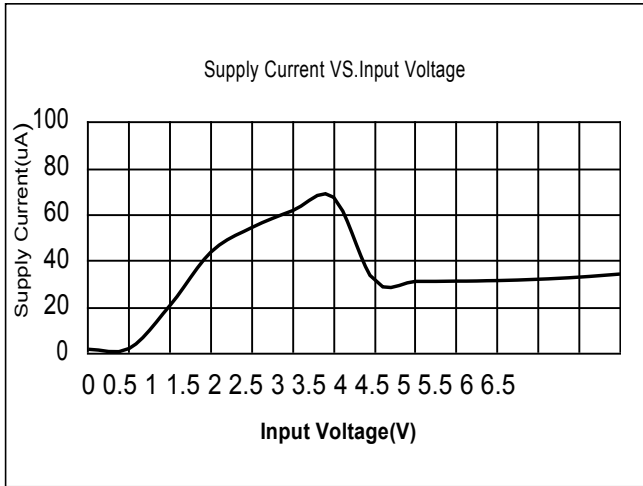

ME6511C30M5G

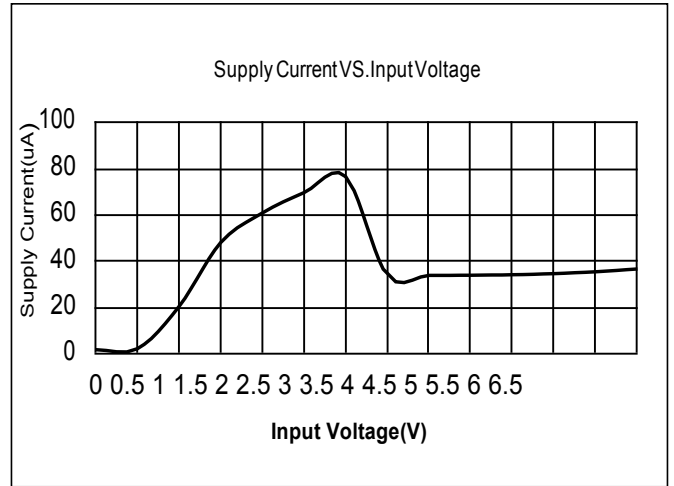

ME6511C28M5G

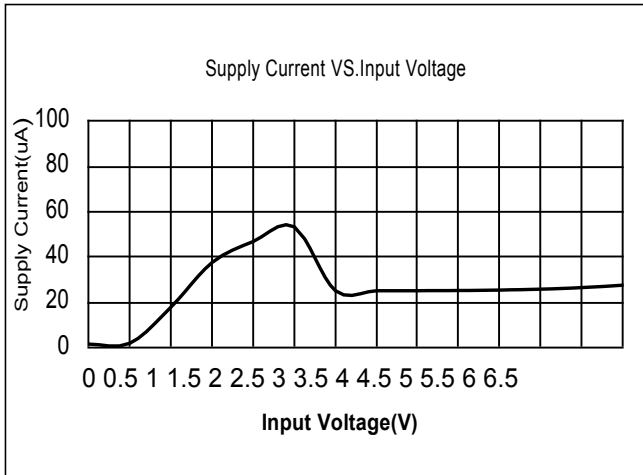

ME6511C18M5G

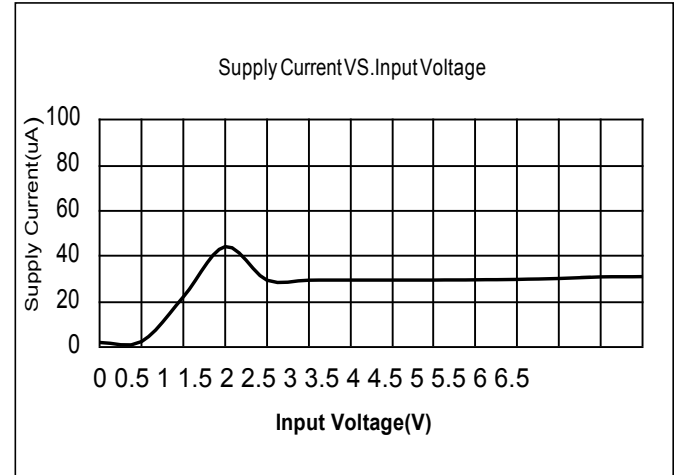

(5) PSRR

ME6511C18M5G

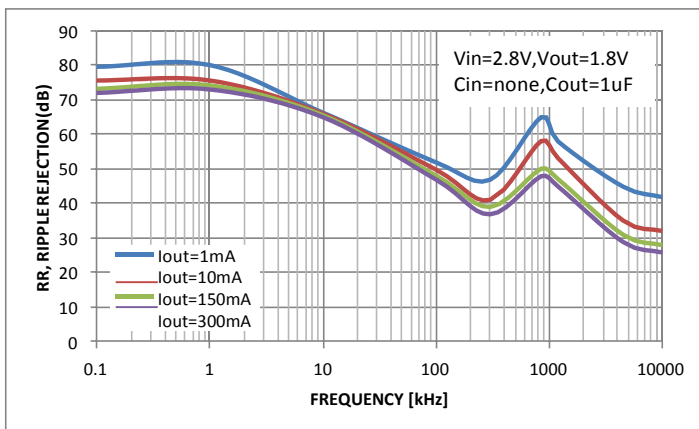

ME6511C28M5G

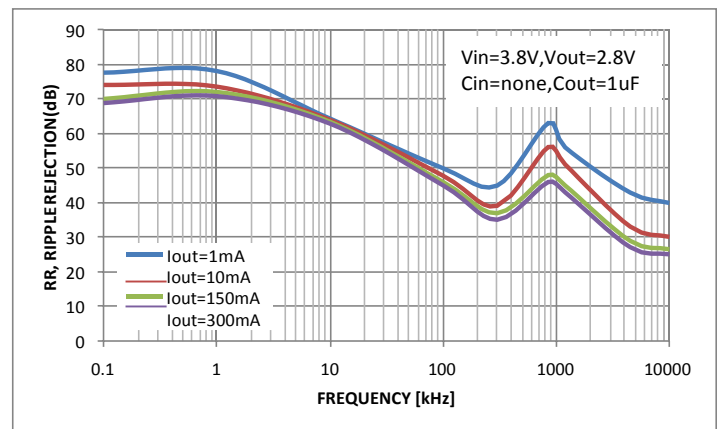

(6) Temperature vs. Output Voltage

ME6511C25

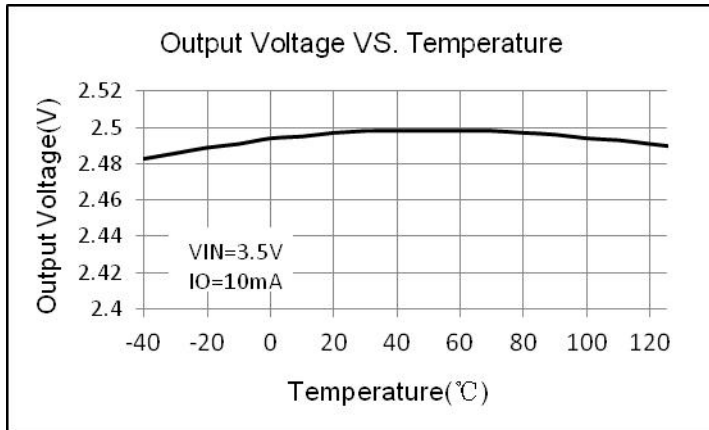

Packaging Information

- Package Type: SOT23-3

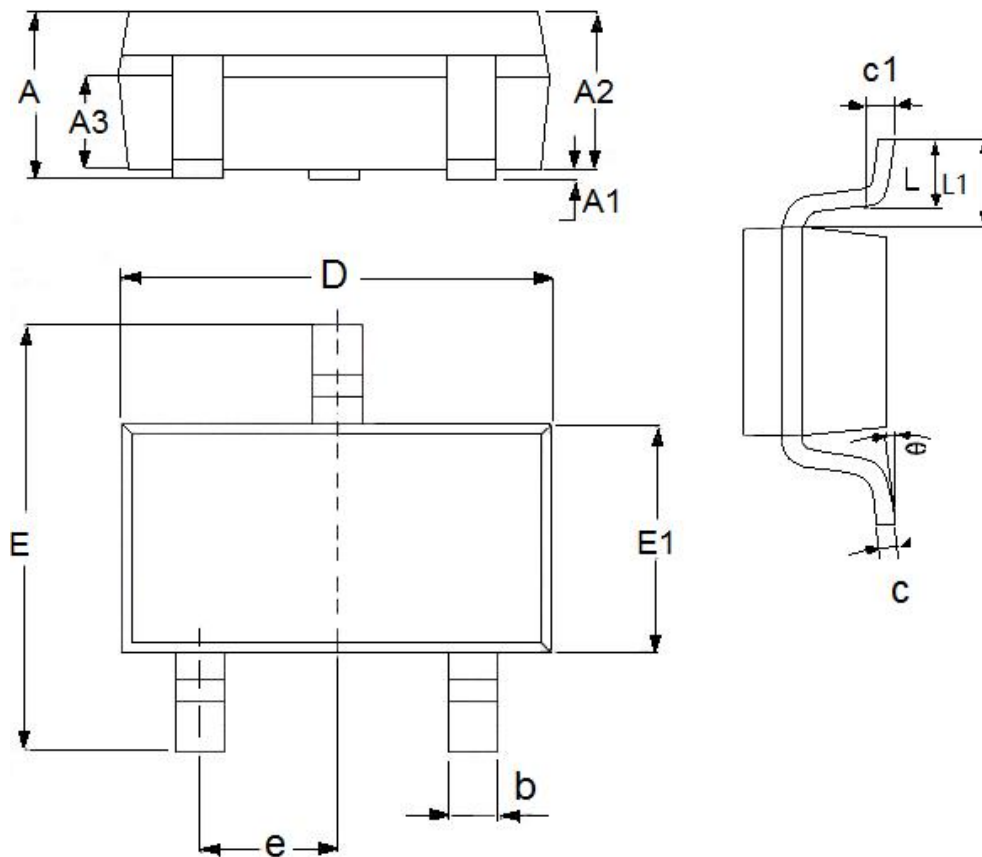

DIM	Millimeters		Inches	
	Min	Max	Min	Max
A	1.05	1.45	0.0413	0.0571
A1	0	0.15	0.0000	0.0059
A2	0.9	1.3	0.0354	0.0512
A3	0.6	0.7	0.0236	0.0276
b	0.25	0.5	0.0098	0.0197
c	0.1	0.25	0.0039	0.0098
D	2.8	3.1	0.1102	0.1220
E	2.6	3.1	0.1023	0.1220
E1	1.5	1.8	0.0591	0.0709
e	0.95(TYP)		0.0374(TYP)	
L	0.25	0.6	0.0098	0.0236
L1	0.59(TYP)		0.0232(TYP)	
θ	0	8°	0.0000	8°
c1	0.2(TYP)		0.0079(TYP)	

● Package Type: SOT89-3

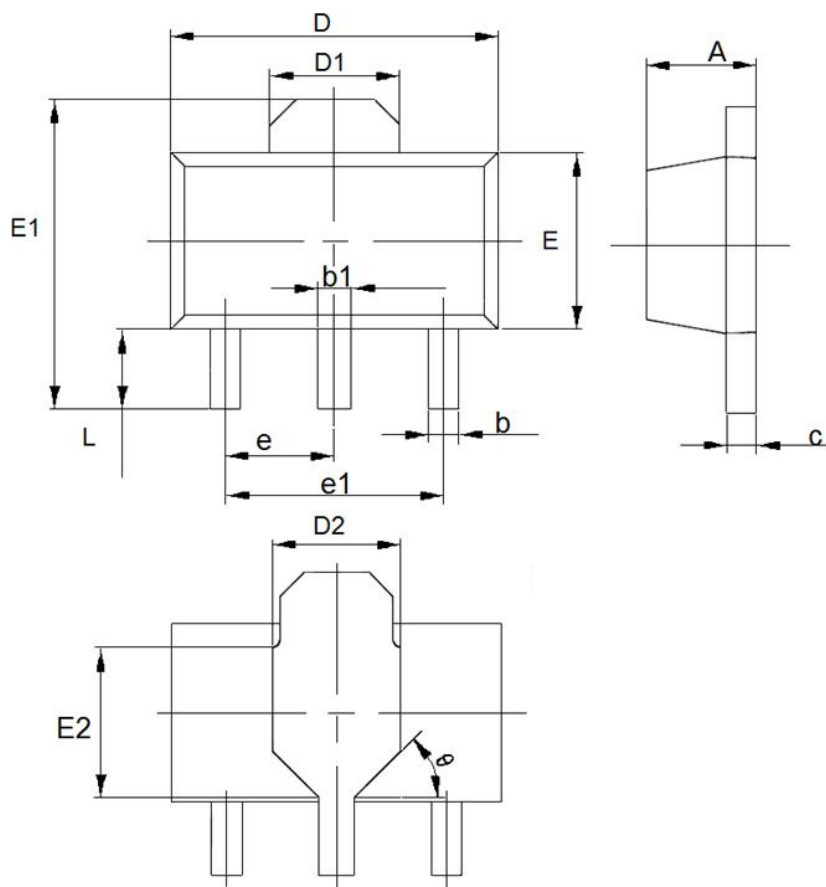

DIM	Millimeters		Inches	
	Min	Max	Min	Max
A	1.4	1.6	0.0551	0.063
b	0.32	0.52	0.0126	0.0205
b1	0.4	0.58	0.0157	0.0228
c	0.35	0.45	0.0138	0.01772
D	4.4	4.6	0.1732	0.1811
D1	1.55(TYP)		0.061(TYP)	
D2	1.75(TYP)		0.0689(TYP)	
e1	3(TYP)		0.1181(TYP)	
E	2.3	2.6	0.0906	0.1023
E1	3.94	4.4	0.1551	0.1732
E2	1.9(TYP)		0.0748(TYP)	
e	1.5(TYP)		0.0591(TYP)	
L	0.8	1.2	0.0315	0.0472
θ	45°		45°	

● Package Type: SOT343R

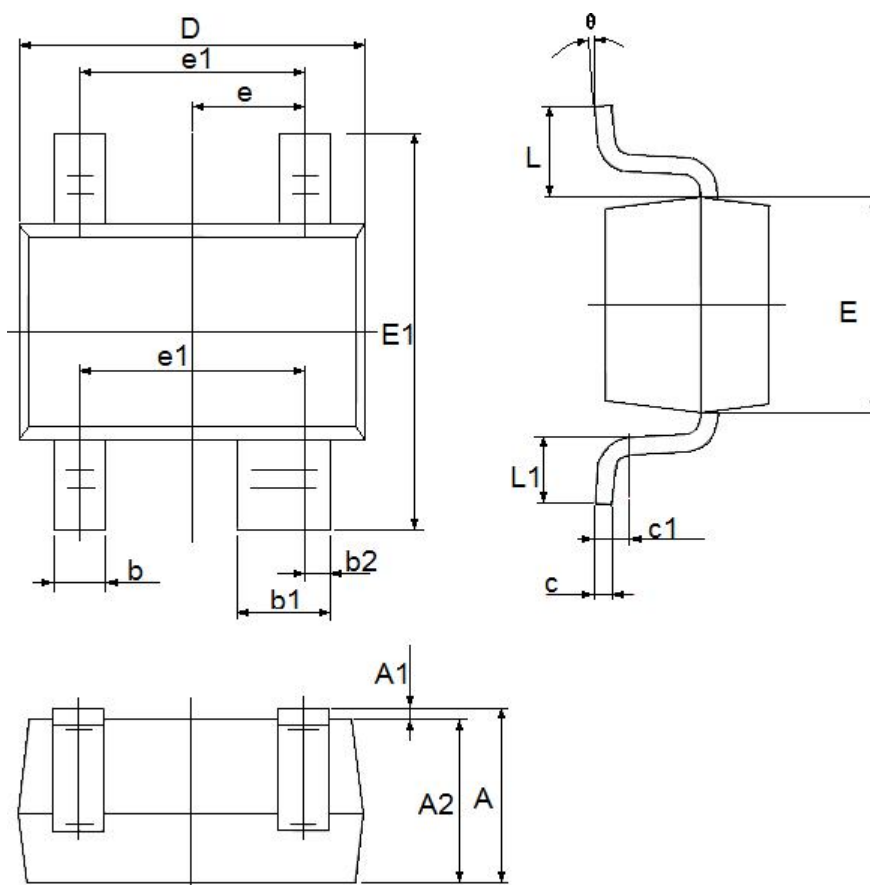

DIM	Millimeters		Inches	
	Min	Max	Min	Max
A	0.900	1.100	0.035	0.043
A1	0.000	0.100	0.000	0.004
A2	0.900	1.000	0.035	0.039
b	0.150	0.350	0.006	0.014
b1	0.350	0.500	0.014	0.020
b2	0.075	0.175	0.003	0.007
c	0.080	0.150	0.003	0.006
D	2.000	2.200	0.079	0.087
E	1.1	1.4	0.0433	0.0551
E1	2.1	2.5	0.0827	0.0984
e	0.65TYP		0.026TYP	
e1	1.200	1.400	0.047	0.055
L	0.525TYP		0.021TYP	
L1	0.260	0.460	0.010	0.018
θ	0.000	8°	0	8°
c1	0.2TYP		0.0079TYP	

- Package Type: FBP1*1-4

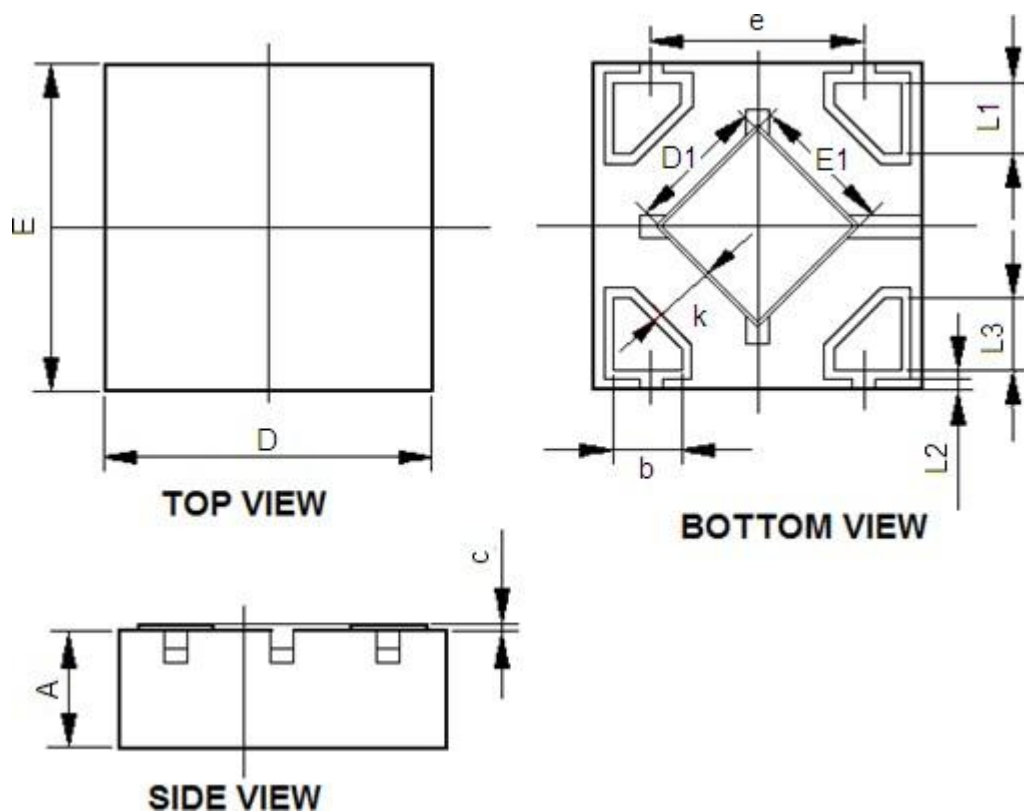

DIM	Millimeters		Inches	
	Min	Max	Min	Max
A	0.335	0.410	0.013	0.016
D	0.950	1.100	0.037	0.043
E	0.950	1.100	0.037	0.043
D1	0.370	0.470	0.015	0.019
E1	0.370	0.470	0.015	0.019
k	0.170MIN		0.007MIN	
b	0.160	0.260	0.060	0.010
C	0.010	0.090	0.000	0.004
e	0.600	0.700	0.024	0.028
L1	0.185	0.255	0.007	0.010
L2	0.03REF		0.001REF	
L3	0.185	0.255	0.007	0.010

● Package Type: SOT23-5

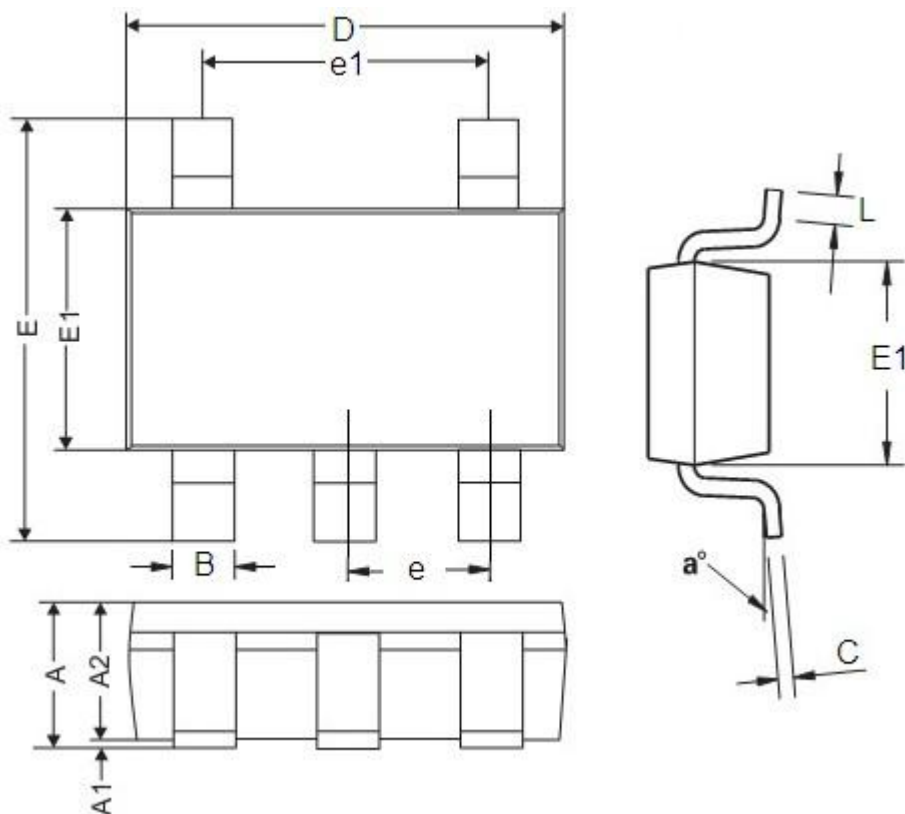

DIM	Millimeters		Inches	
	Min	Max	Min	Max
A	1.05	1.45	0.0413	0.0570
A1	0	0.15	0	0.0059
A2	0.9	1.3	0.0354	0.0511
B	0.25	0.5	0.0098	0.0196
C	0.10	0.23	0.0039	0.0090
D	2.82	3.05	0.1110	0.1200
E	2.60	3.05	0.1023	0.1200
E1	1.50	1.75	0.0590	0.0688
e	0.95REF		0.0374REF	
e1	1.90REF		0.0748REF	
L	0.10	0.60	0.0039	0.0236
a°	0°	30°	0°	30°

● Package Type: SOT353

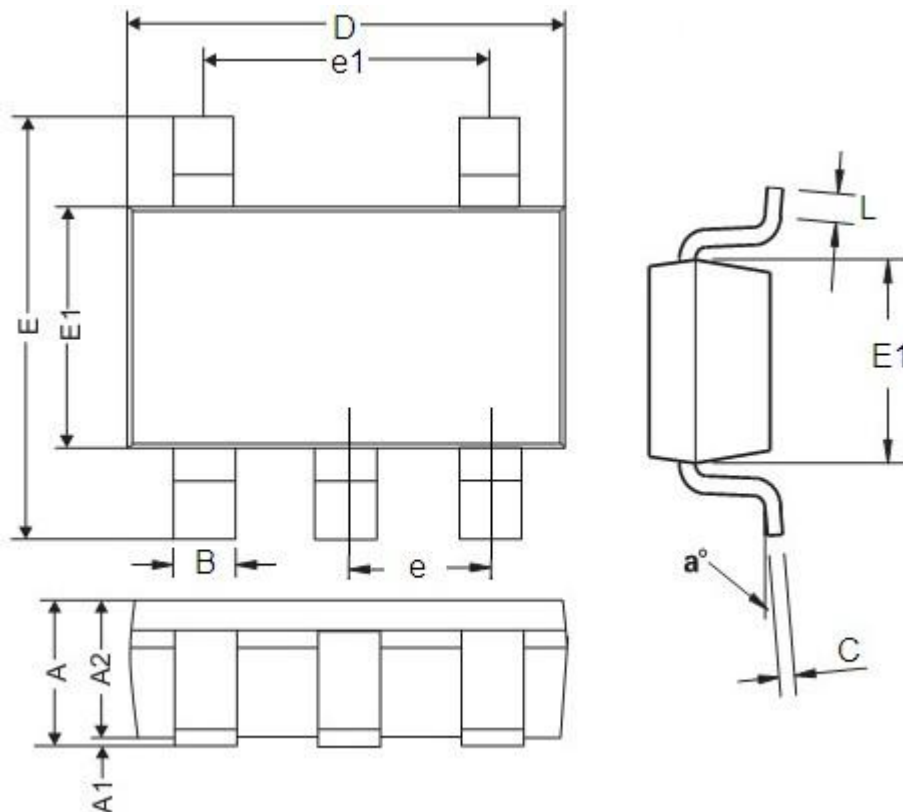

DIM	Millimeters		Inches	
	Min	Max	Min	Max
A	0.9	1.1	0.035	0.043
A1	0.0	0.10	0.00	0.004
A2	0.9	1.0	0.035	0.039
B	0.15	0.35	0.006	0.014
C	0.08	0.15	0.003	0.006
D	2.0	2.2	0.079	0.087
E	2.15	2.45	0.085	0.096
E1	1.15	1.35	0.045	0.096
e	0.65 REF		0.026 REF	
e1	1.20	1.4	0.047	0.055
L	0.26	0.46	0.01	0.018
a°	0°	8°	0°	8°

● Package Type: DFN2*2-6

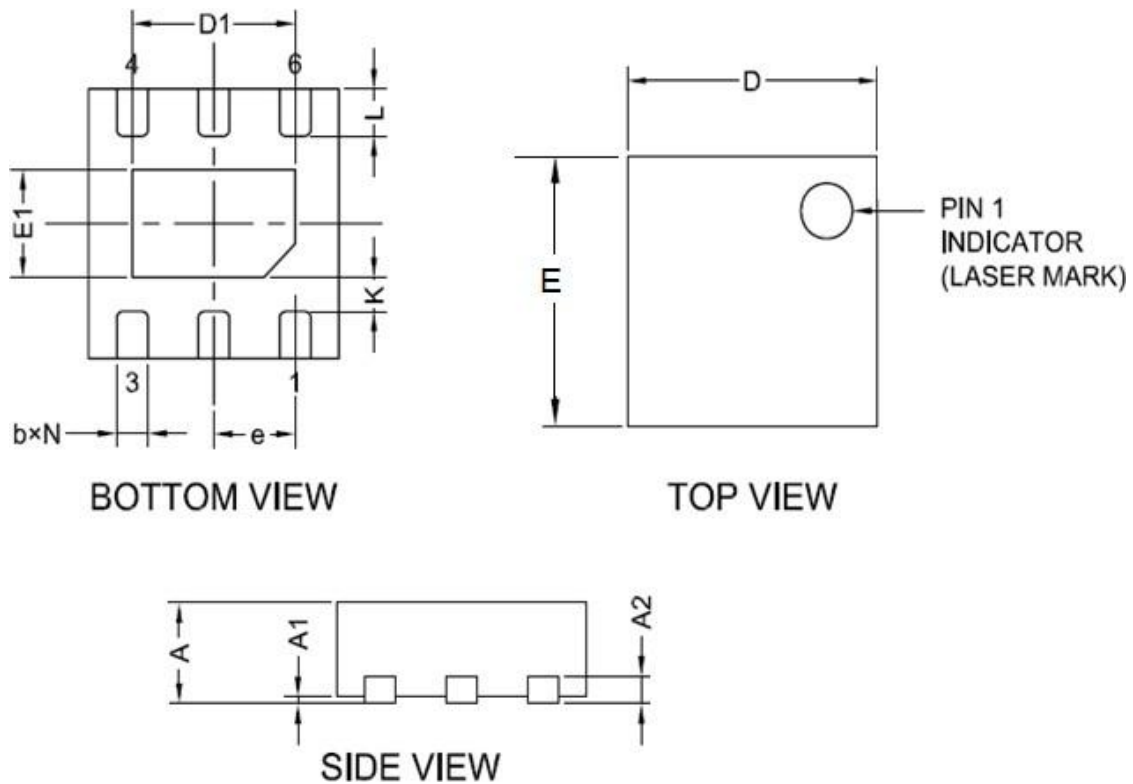

DIM	Millimeters		Inches	
	Min	Max	Min	Max
A	0.7	0.8	0.0276	0.0315
A1	0	0.05	0	0.002
A2	0.203(TYP)		0.008(TYP)	
b	0.2	0.35	0.0078	0.0138
D	1.9	2.1	0.0748	0.0827
E	1.9	2.1	0.0748	0.0827
E1	0.5	0.9	0.0197	0.0354
e	0.65(TYP)		0.0256(TYP)	
L	0.25	0.426	0.0098	0.0168
K	0.2	—	0.0079	—
D1	1	1.45	0.0393	0.0571

- The contents of this document will be updated with the product's improvement without prior notice. Please consult our sales staff before using this document to ensure that you are using the latest version.
- The application circuit examples described in this document are only used to indicate the representative use of the product and do not guarantee the design of mass production.
- Please use this product within the limits stated in this document. We will not be responsible for any damage caused by improper use.
- The products described in this document are not allowed to be used in equipment or devices that affect the human body without the written permission of our company, including but not limited to: health equipment, medical equipment, disaster prevention equipment, fuel control equipment, automobile equipment, aviation equipment and vehicle equipment.
- Although our company has always been committed to improving product quality and reliability, semiconductor products have a certain probability of malfunction or wrong work. To prevent personal injury or property damage caused by such accidents, please pay full attention to safety design, for example: Alternate design, fire protection design, and prevention of wrong action design.
- When exporting this product or this document overseas, you should abide by applicable import and export control laws.
- Copying or reprinting part or all of this document in any form without the permission of our company is strictly prohibited.

X-ON Electronics

Largest Supplier of Electrical and Electronic Components

Click to view similar products for [Linear Voltage Regulators](#) category:

Click to view products by [Micro One](#) manufacturer:

Other Similar products are found below :

[LV56831P-E](#) [LV5684PVD-XH](#) [MCDTSA6-2R](#) [L7815ACV-DG](#) [PQ3DZ53U](#) [LV56801P-E](#) [TLE42794G](#) [L78L05CZ/1SX](#) [L78LR05DL-MA-E](#) [636416C](#) [714954EB](#) [ZMR500QFTA](#) [LV5680P-E](#) [L78M15CV-DG](#) [L79M05T-E](#) [TLS202A1MBVHTSA1](#) [L78LR05D-MA-E](#) [NCV317MBTG](#) [NTE7227](#) [MP2018GZD-33-P](#) [MP2018GZD-5-P](#) [LV5680NPVC-XH](#) [LT1054CN8](#) [MP2018GZD-5-Z](#) [MP2018GZD-33-Z](#) [AT55EL50ESE](#) [APL5934DKAI-TRG](#) [78L05U](#) [78L05](#) [CL9193A15L5M](#) [CL9036A30F4M](#) [CL9036A18F4M](#) [CL9036A25F4M](#) [CL9036A28F4M](#) [CL9036A33F4M](#) [CL9906A18F4N](#) [CL9906A30F4N](#) [CL9908A30F4M](#) [CL9908A33F4M](#) [CL9908A18F4M](#) [CL9908A28F4M](#) [TL431ACM/TR](#) [TL431AIM/TR](#) [LM78L05ACM/TR](#) [HT7812ARMZ](#) [HT7805ARMZ](#) [HT317LRHZ](#) [HXY6206I-3.0](#) [HXY6206I-3.3](#) [XC6206P252MR](#) [XC6206P282MR](#)