

Radiation-Tolerant FPGAs

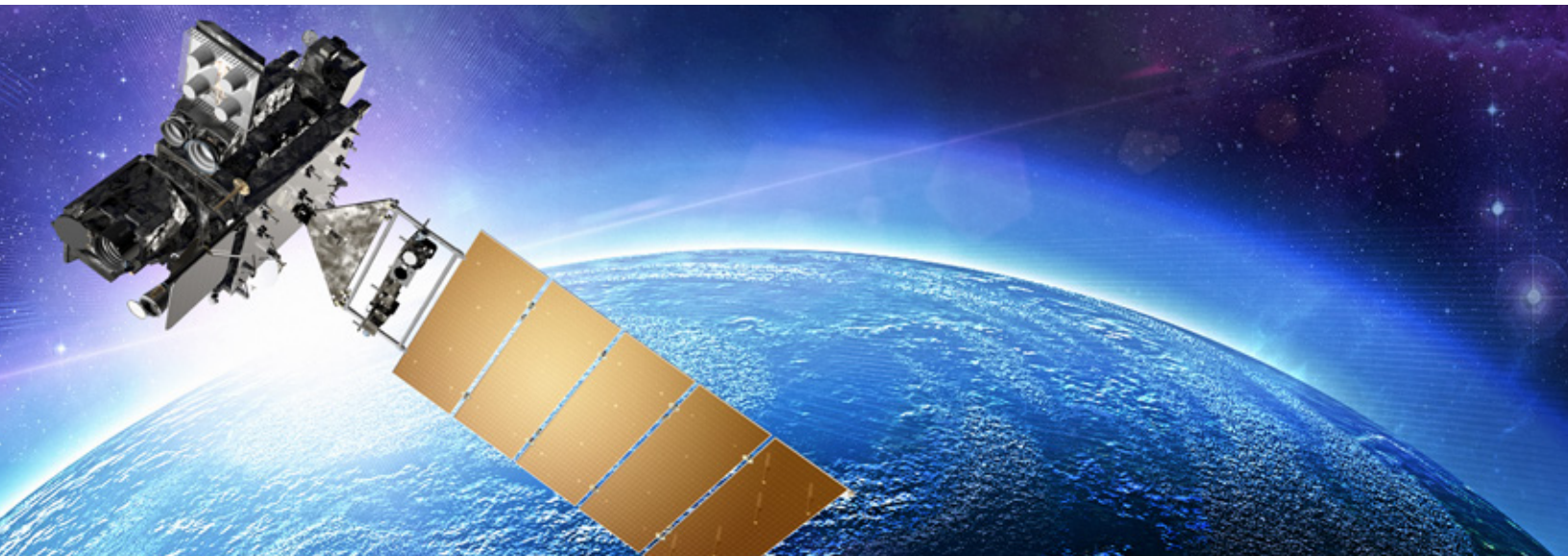

RTG4™

RTAX™-S/SL

RTAX-DSP

RT ProASIC®3

RTSX-SU



The leader in programmable digital logic
for spaceflight applications.

Taking Designs from Earth to Outer Space

Whether you're designing for low earth orbit, deep space or anything in between, **Microsemi's high-reliability, low-power spaceflight FPGAs are your best choice.** With a history of providing the most reliable, robust, low-power flash and antifuse-based FPGAs in the industry, Microsemi offers the best combination of features, performance and radiation tolerance.

In addition to FPGAs, Microsemi provides radiation-hardened and radiation-tolerant solutions ranging from diodes, transistors and power converters, to ASICs, RF components, oscillators and timing products, custom semiconductor packaging, and integrated power distribution systems.

Table of Contents

Radiation-Tolerant FPGAs	<ul style="list-style-type: none">• Microsemi radiation-tolerant FPGAs now delivering high-speed signal processing• Microsemi flight heritage	3
RTG4	<ul style="list-style-type: none">• Developed for high-speed signal processing• Highest performance, most logic resources of any RT FPGA• Immune to radiation configuration upsets• Radiation hardened by design	4
RTAX-S/SL	<ul style="list-style-type: none">• Industry-standard QML Class V qualified RT FPGA• High-performance and low power consumption• Unprecedented 33 M+ device-hours of reliability data from flight and commercially equivalent units	7
RTAX-DSP	<ul style="list-style-type: none">• High-speed arithmetic functions for spaceflight applications• Embedded hardwired radiation-tolerant multipliers• QML Class V qualified	8
RT ProASIC3	<ul style="list-style-type: none">• Very low power consumption spaceflight FPGA• Reprogrammability without radiation-induced configuration upsets• Single-chip form-factor	9
RTSX-SU	<ul style="list-style-type: none">• High-reliability, radiation-tolerant antifuse-based FPGAs• Flight heritage established on many programs	10
FPGA Packages	<ul style="list-style-type: none">• Package dimensions	11
Design Environment for Microsemi System Critical Devices	<ul style="list-style-type: none">• Microsemi's Libero® Integrated Design Environment (IDE) tools and editions	13
Designing with RTG4	<ul style="list-style-type: none">• Development Kit and Design Software	14
Intellectual Property Cores for System Critical FPGAs	<ul style="list-style-type: none">• MIL-STD-1553B IP cores• Digital signal processing IP cores	15
Prototyping Flows	<ul style="list-style-type: none">• Prototyping options for RT FPGA families	16
Package Prototyping Solutions	<ul style="list-style-type: none">• Adapter sockets	17
Daisy-Chained Packages	<ul style="list-style-type: none">• Facilitating PCB assembly validation and package qualification	18
Device Programming	<ul style="list-style-type: none">• Silicon Sculptor 3, FlashPro4 and FlashPro5 device programmers	18

Radiation-Tolerant FPGAs

Microsemi Radiation-Tolerant FPGAs now Delivering High-Speed Signal Processing

Microsemi's FPGAs facilitate the design of high-speed communications payloads, high resolution sensors and instruments, and flight-critical systems that enable tomorrow's space missions. Only Microsemi can meet the power, size, cost and reliability targets that reduce time-to-launch and minimize cost and schedule risks.

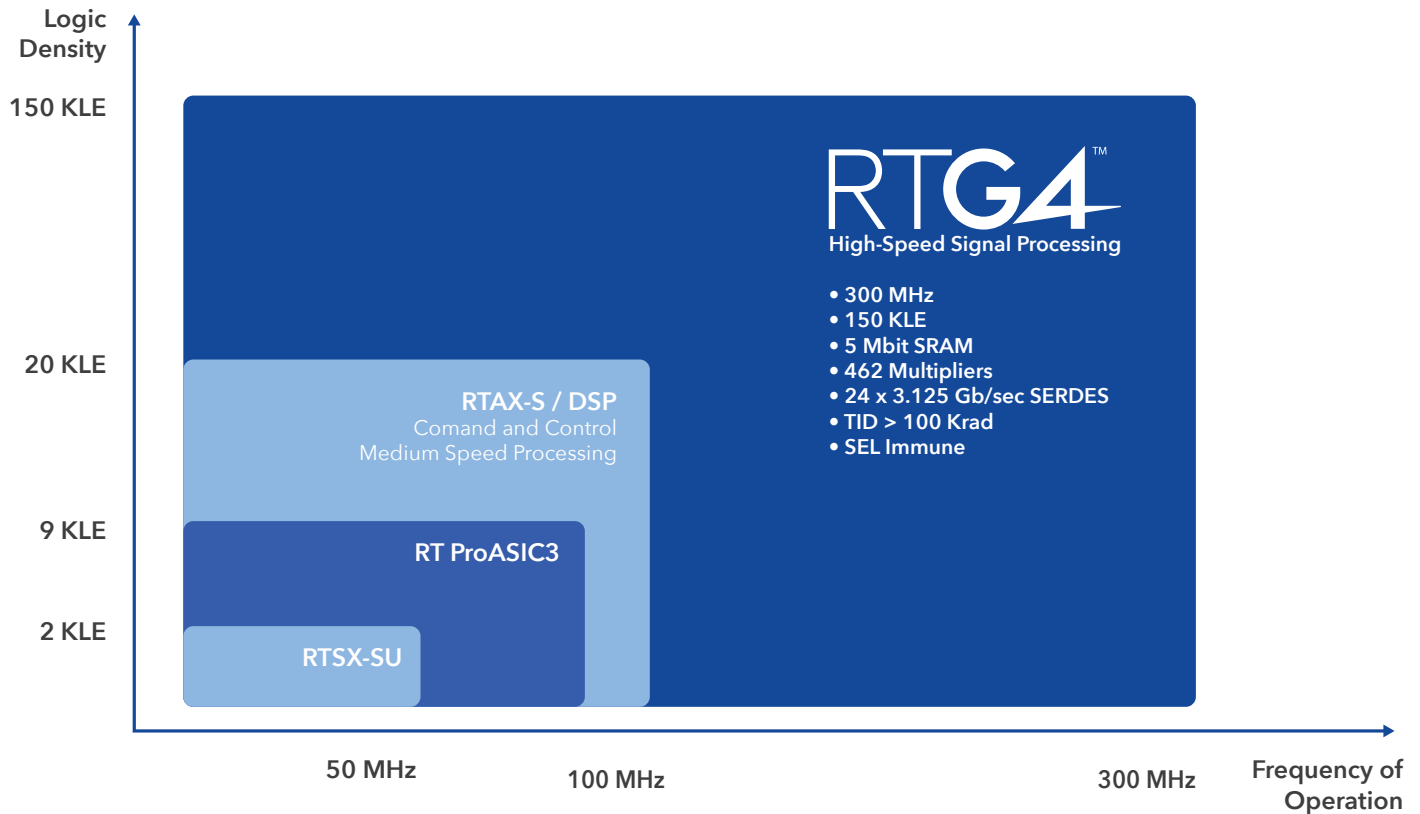

Microsemi Flight Heritage

RTSX-SU

Flight heritage since 2005
EAR controlled
QML class Q qualified

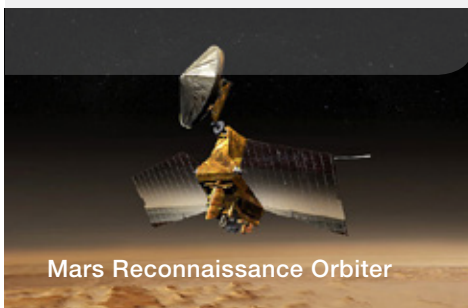

RTAX

Flight heritage since 2007
On-board SRAM and DSP Mathblocks
EAR controlled
QML class V qualified

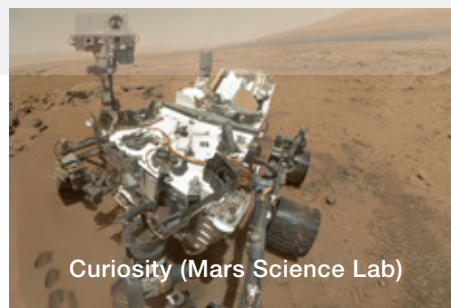

RT ProASIC3

Flight heritage since 2013
First flash-based RT FPGA in space
EAR controlled
QML class Q qualified

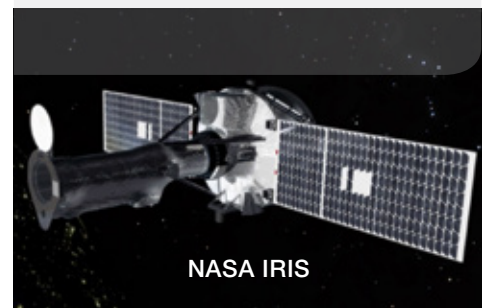

RTG4 High-Speed Signal Processing FPGAs

Remote Sensing Payload Example

Microsemi FPGAs have achieved flight heritage on many programs in command and control applications which require limited amounts of logic and modest performance levels. RTG4 has much greater logic density, and much higher performance, which combined give a > 20X improvement in signal processing throughput. Now designers of high-speed datapaths in space payloads can use RTG4 to take advantage of the flexibility and ease-of-use of programmable logic. This is particularly important for remote sensing instruments, which are required to perform rapidly increasing amounts on-board processing, as sensor resolution is increasing faster than downlink bandwidth.

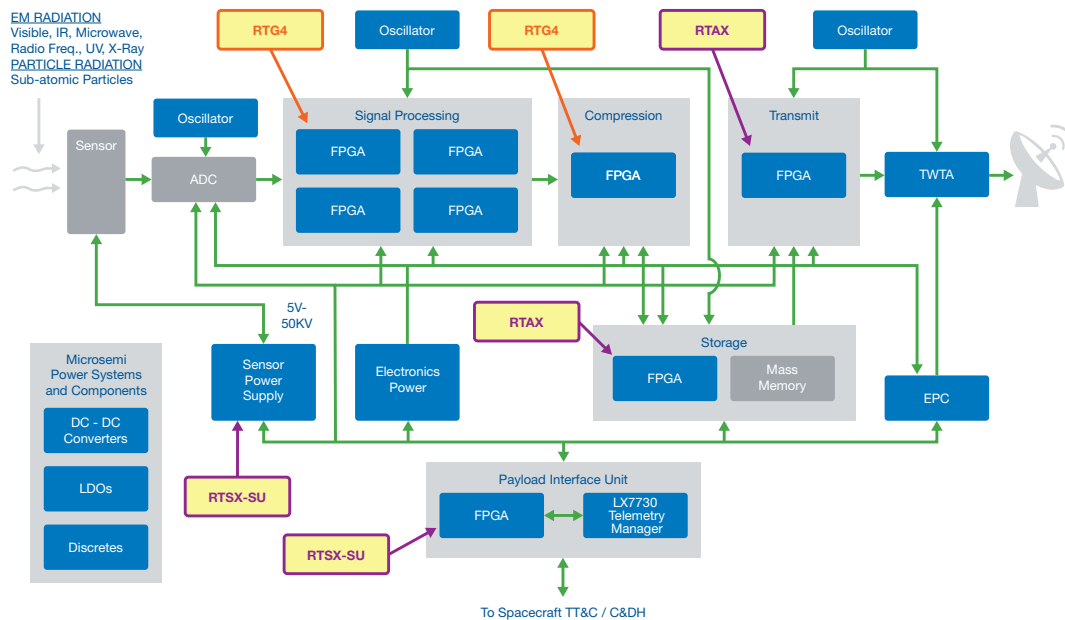

RTSX-SU, RTAX, and RT ProASIC3 FPGAs are used for command, control, and interfacing applications, where limited logic and performance is needed. RTG4 can be deployed where maximum data throughput is needed, for example in signal processing and compression.

RTG4 Radiation Effects

RTG4 FPGAs are manufactured on a low power 65nm process with substantial reliability heritage. RTG4 FPGAs will be qualified to MIL-STD-883 Class B, and Microsemi will seek QML Class Q and Class V qualification.

RTG4 FPGAs are immune to radiation (SEU) induced changes in configuration, due to the robustness of the flash cells used to connect and configure logic resources and routing tracks.

No background scrubbing or reconfiguration of the FPGA is needed in order to mitigate changes in configuration due to radiation effects. Data errors, due to radiation, are mitigated by hardwired SEU resistant flip-flops in the logic cells and in the mathblocks. Single Error Correct Double Error Detect (SECDED) protection is optional for the embedded SRAM (LSRAM and uSRAM) and the DDR memory controllers. This means that if a one-bit error is detected, it will be corrected. Errors of more than one bit are detected only and not corrected. SECDED error signals are brought to the FPGA fabric to allow the user to monitor the status of these protected internal memories.

- Immune to Single Event Latch-Up
- Immune to Configuration Upsets
- Total Ionizing Dose to > 100 Krad (Si)
- Single Event Upsets < 1 x 10⁻¹⁰ Errors / Bit - Day (GEO Solar Min)

RTG4 FPGAs

High-Speed RT FPGAs for Signal Processing Applications

RTG4 FPGAs integrate Microsemi's fourth-generation flash-based FPGA fabric high-performance serialization/deserialization (SERDES transceivers) on a single chip while maintaining the resistance to radiation-induced configuration upsets in the harshest radiation environments, such as space flight (LEO, MEO, GEO, HEO, deep space); high altitude aviation, medical electronics, and nuclear power plant control.

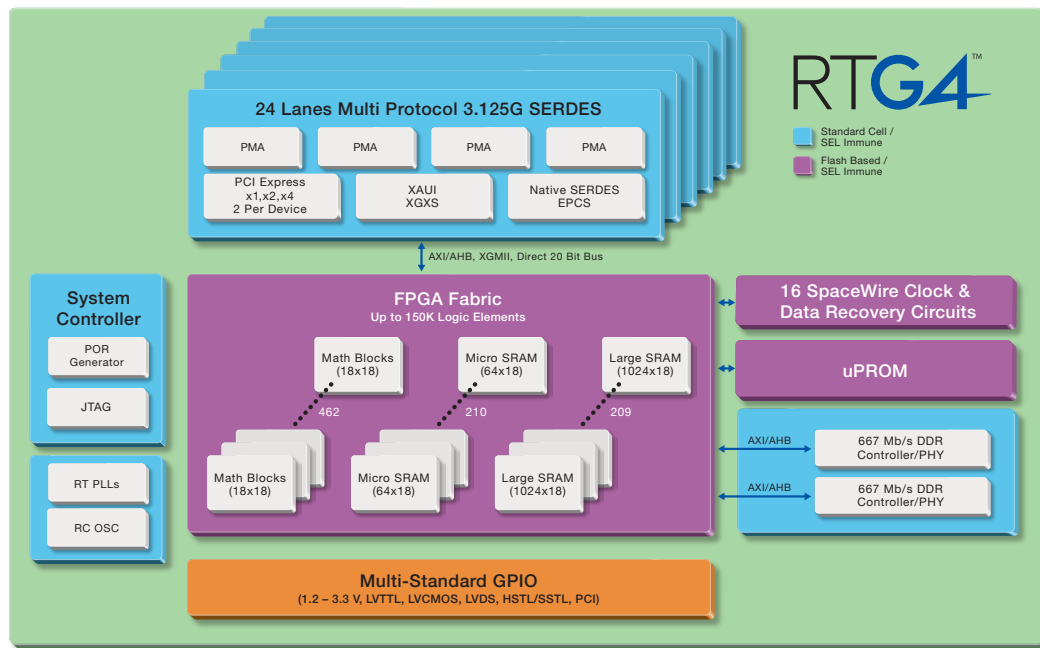

RTG4 Product Family

	Features	RT4G150
Logic / DSP	Maximum Logic Elements (LUT4 + TMR flip-flop)	151,824
	Mathblocks (18-bit x 18-bit)	462
	Radiation-Tolerant PLLs	8
Memory	LSRAM 24.5 kbit Blocks (with ECC)	209
	uSRAM 1.5 kbit Blocks (with ECC)	210
	Total SRAM Mbits	5.3
	uPROM Kbits	374
High-Speed Interface	SERDES lanes (3.125 Gbit/sec)	24
	PCIe Endpoints	2
	DDR2/3 SDRAM Controller (with ECC)	2x32 + 4 bits ECC
	SpaceWire Clock & Data Recovery Circuits	16
User I/Os	MSIO (3.3 V)	240
	MSIOD (2.5 V)	300
	DDRIO (2.5 V)	180
	User IO (excluding SERDES)	720
Packages		COGA/CLGA 1657

RTG4

Logic Module

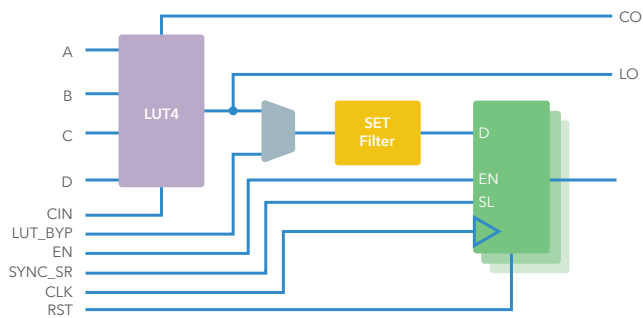

Dedicated STMR Flip-flop with Asynchronous Self Correction

- With enable, global asynchronous set/reset, and local synchronous set/reset
- Fast carry chain to complement Mathblock performance
- 300 MHz for 32-bit functions (no SET filter)
- 250 MHz for 32-bit function (SET filter deployed)
- Industry standard LUT4 for efficient synthesis
- LUT4 and flip-flop in same module can be used independently
- Hierarchical routing architecture enables > 95% module utilization

Mathblock

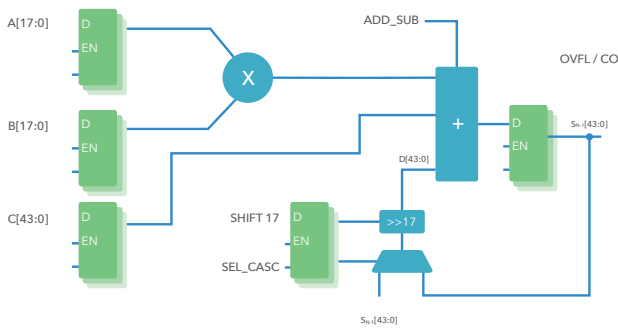

18 x 18 multiplier with advanced accumulate

- High performance for signal processing throughput
- 300 MHz without SET mitigation
- 250 MHz with SET mitigation
- New 3-input adder function: $(C + D) \pm (A * B)$
- Optional SEU-protected registers on inputs and outputs (including C input)

Memory Blocks

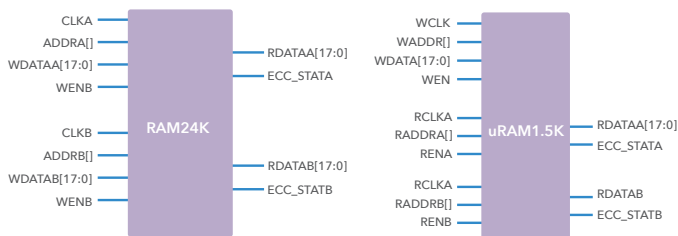

Radiation-Tolerant Built-in optional EDAC (SECDED)

- Resistant to multi-bit upset

LSRAM – up to 24.5 KBit

- Dual-port and two-port options
- High performance synchronous operation
- Example usage - Large FFT memory

uRAM – up to 1.5 KBit

- Three Port Memory - Synchronous Write Port, Two Asynchronous or Synchronous Read Ports
- Example usage - Folded FIR filters and FFT twiddle factors

SpaceWire Receiver Interface

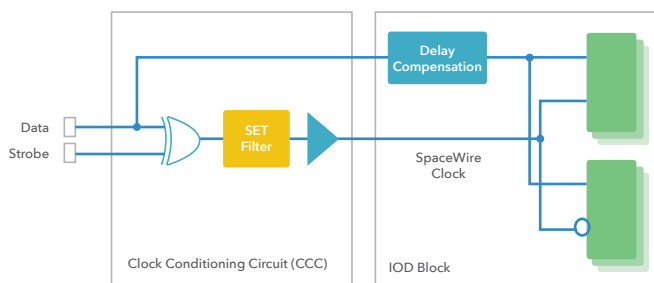

SpaceWire Clock and Data Recovery

- 16 Hardwired Clock and Data Recovery Circuits
- Up to 400 Mb / sec SpaceWire data rate
- Delay compensation for optimum alignment of clock and data
- Supports LVDS and LVTTTL inputs

RTAX-S/SL

Radiation-tolerant FPGA alternative to radiation-hardened ASICs

RTAX-S/SL radiation-tolerant FPGAs offer industry-leading advantages for designers of spaceflight systems. High performance and low power consumption, true single-chip form factor and live-at-power-up operation all combine to make RTAX-S/SL devices the FPGAs of choice for space designers.

- Single event latch-up (SEL) immune to LET_{TH} in excess of 117 MeV-cm²/mg
- Single event upset (SEU) less than 1E⁻¹⁰ errors per bit-day (worst-case geosynchronous orbit)
- Total ionizing dose (TID): 300 krad functional, 200 krad parametric
- Pin-compatible commercial devices for easy and inexpensive prototyping
- Ceramic package offerings (CQFP, CCGA, CLGA)
- Prototype units with same footprint and timing as flight units
- Up to 840 user-programmable I/Os
- Screening:
B Flow: MIL-STD-883B
E Flow: Microsemi Extended Flow
V Flow: MIL-PRF-38535 QML Class V

RTAX-S/SL Devices

RTAX-S/SL Devices	RTAX250S/SL	RTAX1000S/SL	RTAX2000S/SL	RTAX4000S/SL
Capacity				
Equivalent System Gates	250,000	1,000,000	2,000,000	4,000,000
Modules				
Register (R-cells)	1,408	6,048	10,752	20,160
Combinatorial (C-cells)	2,816	12,096	21,504	40,320
Embedded RAM/FIFO (without EDAC)				
RAM Blocks	12	36	64	120
RAM (k = 1,024 bits)	54k	162k	288k	540k
Clocks (segmentable)				
Hardwired	4	4	4	4
Routed	4	4	4	4
I/Os				
I/O Banks	8	8	8	8
User I/Os (maximum)	248	418	684	840
I/O Registers	744	1,548	2,052	2,520
Package Pins				
CG/LG	624	624	624, 1152	1272
CQ	208, 352	352	256, 352	352

I/Os Per Package

RTAX-S/SL Devices	RTAX250S/SL				RTAX1000S/SL				RTAX2000S/SL				RTAX4000S/SL			
	Single-Ended I/Os	Differential I/O Pairs	Non-Adjacent I/O Pairs	Total I/Os	Single-Ended I/Os	Differential I/O Pairs	Non-Adjacent I/O Pairs	Total I/Os	Single-Ended I/Os	Differential I/O Pairs	Non-Adjacent I/O Pairs	Total I/Os	Single-Ended I/Os	Differential I/O Pairs	Non-Adjacent I/O Pairs	Total I/Os
CQ208	7	41	13	115	-	-	-	-	-	-	-	-	-	-	-	-
CQ256	-	-	-	-	-	-	-	-	4	66	0	136	-	-	-	-
CQ352	2	98	0	198	2	98	0	198	2	98	0	198	4	81	0	166
CG624	0	124	0	248	68	170	5	418	52	178	5	418	-	-	-	-
CG1152	-	-	-	-	-	-	-	-	0	342	0	684	-	-	-	-
CG1272	-	-	-	-	-	-	-	-	-	-	-	-	0	420	0	840

Note: An en dash (-) indicates that the device/package combination is not available.

RTAX-DSP

Industry's most reliable spaceflight FPGAs with DSP capabilities

RTAX-DSP spaceflight FPGAs add embedded radiation-tolerant multiply-accumulate blocks to the tried-and-trusted industry standard RTAX-S/SL product family. The result is a dramatic increase in device performance and utilization when implementing arithmetic functions, such as those encountered in DSP algorithms, without sacrificing reliability or radiation tolerance. RTAX-DSP integrates complex DSP functions into a single device without any external components for code storage and without multiple-chip implementations for radiation mitigation.

- Highly reliable, nonvolatile antifuse technology
- 2,000,000 to 4,000,000 system gates
- Up to 120 DSP Mathblocks with 125 MHz 18x18 bit multiply-accumulate
- Up to 540 kbits of embedded memory with optional EDAC protection
- Up to 840 user-programmable I/Os
- RTAX-DL version with low static power
- Total dose: 300 krad (functional) and 200 krad (parametric)
- SEU less than $1E^{-10}$ errors per bit-day (worst-case GEO)
- SEL immune to LET_{TH} in excess of 117 MeV-cm²/mg
- Enhanced SET for R-cells: 0.12 events / RTAX2000D device / 100 years at 120 MHz
- Advanced CCGA and LGA packaging for space applications
- Screening:
B Flow: MIL-STD-883B
E Flow: Microsemi Extended Flow
V Flow: MIL-PRF-38535 QML Class V

RTAX-DSP Devices

RTAX-DSP Devices	RTAX2000D/DL	RTAX4000D/DL
Capacity		
Equivalent System Gates	2,000,000	4,000,000
Modules		
Register (R-cells)	9,856	18,480
Combinatorial (C-cells)	19,712	36,960
Embedded Multiply-Accumulate Blocks		
DSP Mathblocks	64	120
Embedded RAM/FIFO (without EDAC)		
RAM Blocks	64	120
RAM (k=1,024 bits)	288k	540k
Clocks (segmentable)		
Hardwired	4	4
Routed	4	4
I/Os		
I/O Banks	8	8
User I/Os (maximum)	684	840
I/O Registers	2,052	2,520
Package Pins		
CG/LG (DSP)*	1272	1272
CQ	352	352

Note:
* The body size of the 1272-pin CCGA and LGA packages used on the RTAX4000D/DL FPGAs are slightly larger than the body size of the 1272-pin CCGA and LGA used on the RTAX4000S/SL devices.

I/Os Per Package

RTAX-DSP Devices	RTAX2000D	RTAX4000D
CQ352	166	166
CG1272/LG1272	684	840

Note:
The user I/Os include clock buffers.

RT ProASIC3

Low power, reprogrammable FPGAs for space

Radiation-tolerant (RT) ProASIC3 FPGAs are the first to offer designers of spaceflight hardware a radiation-tolerant, reprogrammable, nonvolatile logic integration vehicle. They are intended for low power space applications requiring up to 3,000,000 system gates.

- Ceramic column grid array with Six Sigma™ copper-wrapped lead-tin columns
- Supports single-voltage system operation
- Total ionizing dose: 25 krad to 30 krad with less than 10% propagation delay change at standard test dose rate; up to 40 krad at low dose rate
- Up to 504 kbits of true dual-port SRAM
- Live-at-power-up (LAPU) level 0 support
- In System Programming (ISP) protected with industry standard on-chip 128-bit advanced encryption
- Standard (AES) decryption via JTAG (IEEE 1532-compliant)
- Screening:
B Flow: MIL-STD-883B
E Flow: Microsemi Extended Flow

RT ProASIC3 Devices

RT ProASIC3 Devices	RT3PE600L	RT3PE3000L
System Gates	600,000	3,000,000
VersaTiles (D-flip-flops)	13,824	75,264
RAM (k = 1,024 bits)	108k	504k
RAM Blocks (4,608 bits)	24	112
FlashROM (kbits)	1	1
Secure (AES) ISP	Yes	Yes
Integrated PLL in CCCs	6	6
VersaNet Globals	18	18
I/O Banks	8	8
Maximum User I/Os	270	620
Package Pins		
CG/LG	484	484, 896
CQ	256	256

I/Os Per Package

RT ProASIC3 Devices	RT3PE600L		RT3PE3000L	
	Single-Ended I/Os	Differential I/O Pairs	Single-Ended I/Os	Differential I/O Pairs
CG/LG484	270	135	341	168
CG/LG896	–	–	620	310
CQ256	166	82	166	82

RTSX-SU

Flight-proven in space—time after time

RTSX-SU radiation-tolerant FPGAs are enhanced versions of Microsemi’s commercial SX-A family of devices, specifically designed for enhanced radiation performance. Featuring SEU-hardened D-type flip-flops that offer the benefits of triple module redundancy (TMR) without requiring cumbersome user intervention, the RTSX-SU family is a unique product for space applications.

- Very low power consumption (up to 68 μ W at standby)
- 3.3 V and 5.0 V mixed voltage
- Configurable I/O support for 3.3 V / 5 V PCI, LVTTTL, TTL and CMOS
- Secure programming technology protects against reverse engineering and design theft
- 100% circuit resource utilization with 100% pin locking
- Unique in-system diagnostic and verification capability with Silicon Explorer II
- Low cost prototyping option
- Deterministic, user-controllable timing
- JTAG boundary scan testing in compliance with IEEE Standard 1149.1 — dedicated JTAG reset (TRST) pin
- Highly reliable, nonvolatile antifuse technology
- 32,000 to 72,000 ASIC gates (48,000 to 108,000 system gates)
- Up to 360 user-programmable I/Os
- Hermetically-sealed packages for space applications (CQFP, CCGA/CLGA, CCLG)

RTSX-SU Devices

RTSX-SU Devices	RTSX32SU	RTSX72SU
Capacity		
Typical Gates	32,000	72,000
System Gates	48,000	108,000
Logic Modules		
Combinatorial Cells	1,800	4,024
SEU-Hardened Register Cells (D-flip-flops)	1,080	2,012
Maximum Flip-Flops	1,980	4,024
Maximum User I/Os	227	360
Clocks	3	3
Quadrant Clocks	0	4
Speed Grades	Std., -1	Std., -1
Package Pins		
CQ	84, 208, 256	208, 256
CG		624
CC	256	

I/Os Per Package

RTSX-SU Devices	RTSX32SU	RTSX72SU
CQ84	62	–
CQ208	173	170
CQ256	227	212
CC256	202	–
CG624	–	360

Note:
The user I/Os include clock buffers.

FPGA Packages

Key: **bs** – package body size excluding leads **h** – package thickness **p** – pin pitch / ball pitch



CQ352 **b.s.** 1.890x1.890" (48.00x48.00 mm)
h. 105 mils (2.67 mm) **p.** 20 mils (0.50 mm)

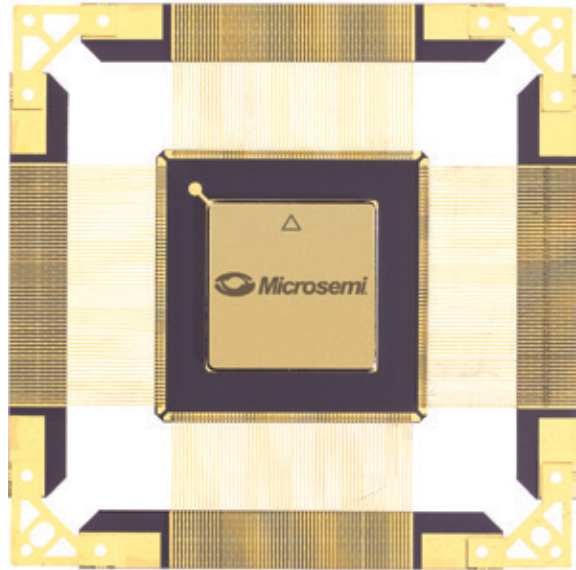

CQ256 **b.s.** 1.417x1.417" (36.00x36.00 mm)
h. 105 mils (2.67 mm) **p.** 20 mils (0.50 mm)



CQ172 **b.s.** 1.18x1.18" (29.972x29.972 mm)
h. 105 mils (2.67 mm) **p.** 25 mils (0.64 mm)

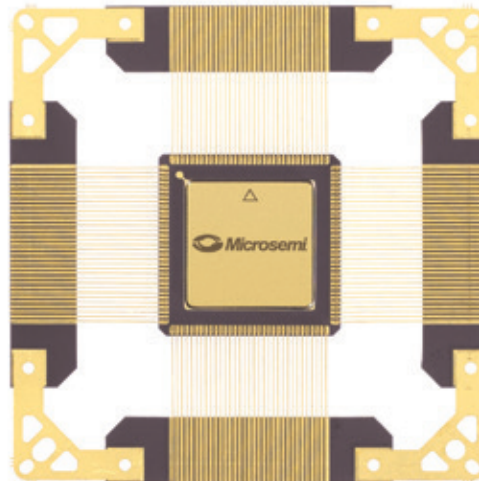

CQ132 **b.s.** 0.95x0.95" (24.13x24.13 mm)
h. 105 mils (2.67 mm) **p.** 25 mils (0.64 mm)

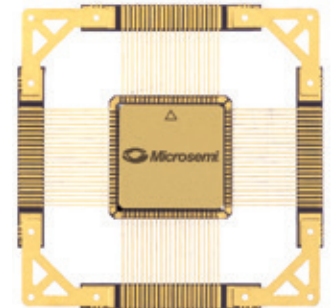

CQ84 **b.s.** 0.65x0.65" (16.51x16.51 mm)
h. 90 mils (2.29 mm) **p.** 25 mils (0.64 mm)

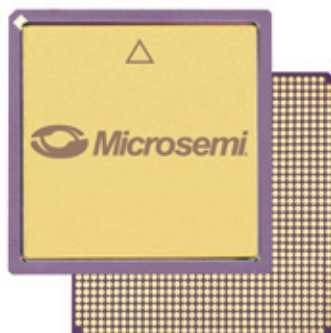

CG1152/LG1152

RTAX2000S and RTAX2000SL only
b.s. 1.378x1.378" (35.00x35.00 mm)
h. CCGA – 218 mils (5.535 mm)
h. LGA – 129 mils (3.28 mm)
p. 39 mils (1.00 mm)

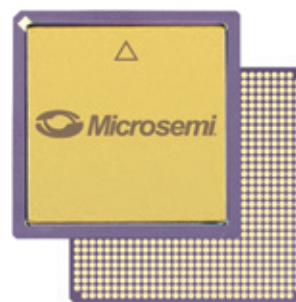

CG896/LG896

b.s. 1.220x1.220" (31.00x31.00 mm)
h. CCGA – 218 mils (5.535 mm)
h. LGA – 129 mils (3.28 mm)
p. 39 mils (1.00 mm)

The b.s. dimension is the nominal package body dimension, exclusive of leads. For more information refer to the Microsemi Package Mechanical Drawings document located at www.microsemi.com/products/fpga-soc/radtolerant-fpgas/rtax-s-sl#documents

FPGA Packages

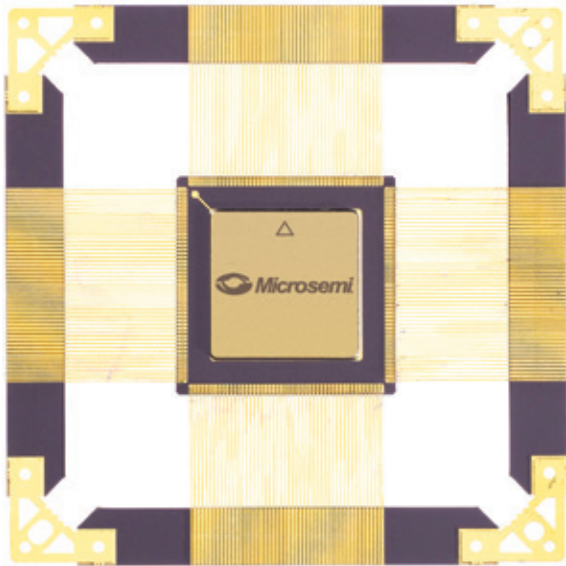

CQ208 **b.s.** 1.15x1.15" (29.21x29.21 mm)
h. 105 mils (2.67 mm) **p.** 20 mils (0.50 mm)

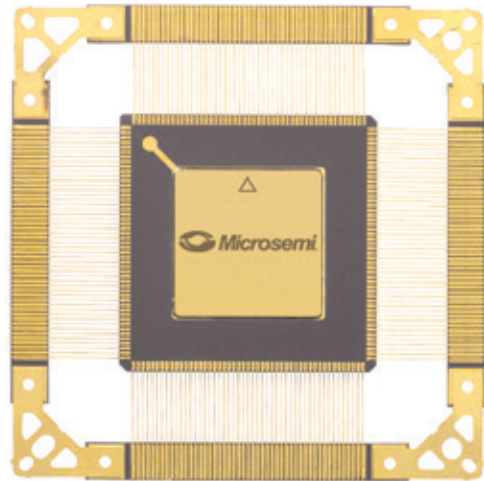

CQ196 **b.s.** 1.35x1.35" (34.29x34.29 mm)
h. 105 mils (2.67 mm) **p.** 25 mils (0.64 mm)

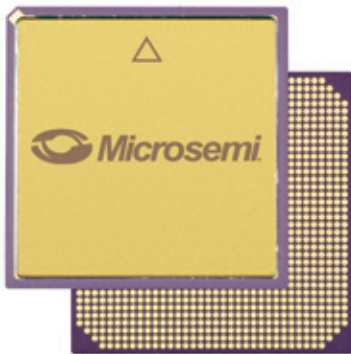

CB1657/CG1657/LG1657 RT4G075, RT4G150
b.s. 1.693x1.693" (43x43mm) **h.** CBGA - 156 mils (3.97mm)
h. CCGA - 213 mils (5.42mm) **h.** CLGA - 126 mils (3.21mm)
p. 39 mils (1.00mm)



CGD1272/LGD1272 RTAX4000D only
b.s. 1.594x1.594" (40.5x40.5mm) **h.** CCGA - 218 mils (5.535 mm)
h. CLGA - 129 mils (3.28 mm) **p.** 39 mils (1.00 mm)

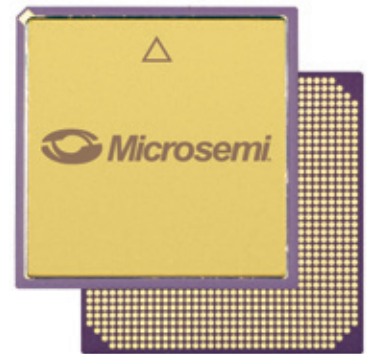

CG1272/LG1272 RTAX4000S, RTAX4000SL,
 and RTAX2000D only
b.s. 1.457x1.457" (37.00x37.00 mm) **h.** CCGA - 218
 mils (5.535 mm) **h.** CLGA - 129 mils(3.28 mm)
p. 39 mils (1.00 mm)

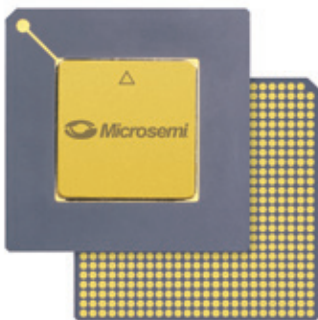

CG624/LG624
b.s. 1.27x1.27"
 (32.50x32.50 mm)
h. CCGA - 194 mils
 (4.94 mm)
h. LGA - 90 mils
 (2.30 mm)
p. 50 mils
 (1.27 mm)

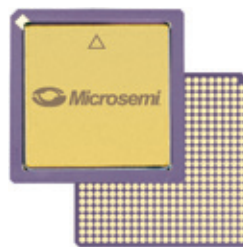

CG484/LG484
b.s. 0.91x0.91"
 (23.00x23.00 mm)
h. CCGA - 225 mils
 (5.72 mm)
h. LGA - 138 mils
 (3.51 mm)
p. 7.5 mils
 (0.19 mm)



CC256
b.s. 0.67x0.67"
 (17.00x17.00 mm)
h. 72 mils
 (1.847 mm)
p. 7.5 mils
 (0.19 mm)

Libero IDE for Microsemi System Critical Devices

Libero IDE should be used for designing with Microsemi antifuse and legacy flash FPGAs. Libero IDE supports:

SX/SX-A (including RTSX/-S/-SU)

Accelerator® (including RTAX-S, RTAX-DSP)

Microsemi system critical FPGAs are fully supported by Microsemi's Libero® Integrated Design Environment (IDE) software. Libero IDE is an integrated design manager that integrates design tools while guiding the user through the design flow, managing all design and log files and passing necessary design data among tools. Libero IDE allows users to integrate both schematic and HDL synthesis into a single flow and verify the entire design in a single environment. Libero IDE includes Synplify Pro® AE from Synopsys®, ModelSim® HDL Simulator from Mentor Graphics and Designer design implementation software from Microsemi.

Designer software includes sophisticated place-and-route features plus a comprehensive suite of backend support tools for timing constraints, timing and power analysis, I/O attribute and pin assignment, and much more.

Microsemi's SmartDesign tool simplifies the use of Microsemi's IP in user designs as well as offering a simple way to build on-chip processors with custom peripherals. Most Microsemi IP cores are now included by default in Libero IDE as either obfuscated or RTL versions, depending on the license selected.

For embedded designers, Microsemi offers FREE SoftConsole Eclipse-based IDE for use with ARM® Cortex™-M1 and Cortex-M3, and Core8051s as well as evaluation versions from Keil™ and IAR Systems®. Full versions are available from the respective suppliers.

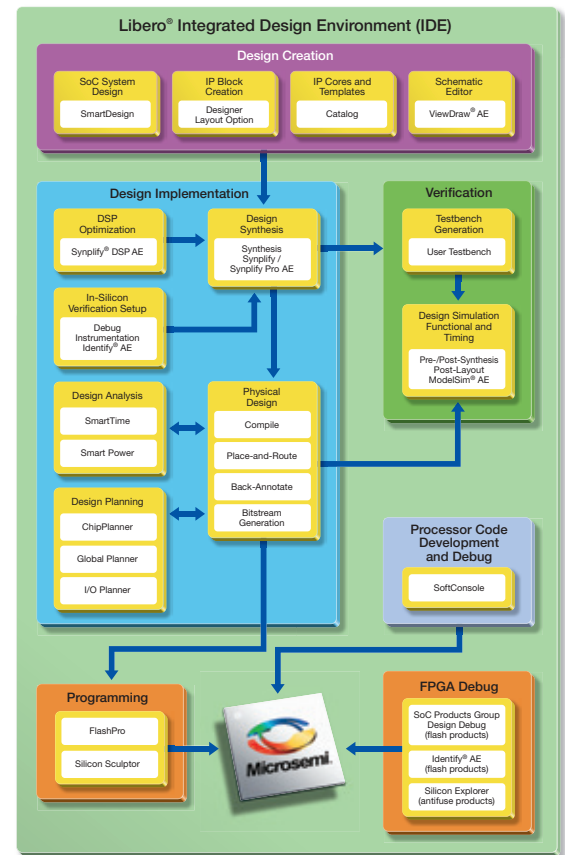

FPGA Design Support

Libero IDE Licenses		Gold (FREE)	Platinum	Standalone
Device Support	All families	Up to 1,500,000 gates	All devices	All devices
Microsemi IP		RTL	RTL	RTL
Synthesis	Synplify® Pro ME	x	x	
Simulation	ModelSim® ME	x	x	
Debug	Identify® ME	x	x	
	Microsemi Debug	x	x	x
Program File		x	x	

Operating System Support*

Tool	Libero IDE	SoftConsole	Keil	IAR	FlashPro	FlashPro USB Driver
Windows® XP Professional	•	•	•	•	•	Now (32-bit and 64-bit)
Windows 7 Professional	•	•	•	•	•	Now (32-bit and 64-bit)
RHEL 5 (Tikanga)1	•	-	-	-	-	-
RHEL 6 (Tikanga)2	•	-	-	-	-	-

Note:
* FPGA programming is only supported in Windows XP Pro, Windows Vista, and Windows 7.

Designing with RTG4

RTG4 Development Kit

The RTG4 Development Kit provides space customers with an evaluation and development platform for applications such as data transmission, serial connectivity, bus interface and high-speed designs using the latest Radiation-Tolerant High-Density High-Performance FPGAs family, RTG4. The development board features an RT4G150 device offering more than 150,000 logic elements in a ceramic package with 1,657 pins.

The RTG4 Development Kit board includes the following features:

- Two 1GB DDR3 synchronous dynamic random access memory (SDRAM)
- 2GB SPI flash memory
- PCI Express Gen 1 x1 interface
- PCIe x4 edge connector
- One pair SMA connectors for testing of the full-duplex SERDES channel
- Two FMC connectors with HPC/LPC pinout for expansion
- RJ45 interface for 10/100/1000 Ethernet
- USB micro-AB connector
- Headers for SPI, GPIOs
- FTDI programmer interface to program the external SPI flash
- JTAG programming interface
- RVI header for application programming and debug
- Embedded FlashPro5 programmer
- Flashpro programming header available if external programmer is used
- Embedded trace macro (ETM) cell header for debug
- Dual in-line package (DIP) switches for user application
- Push-button switches and LEDs for demo purposes
- Current measurement test points

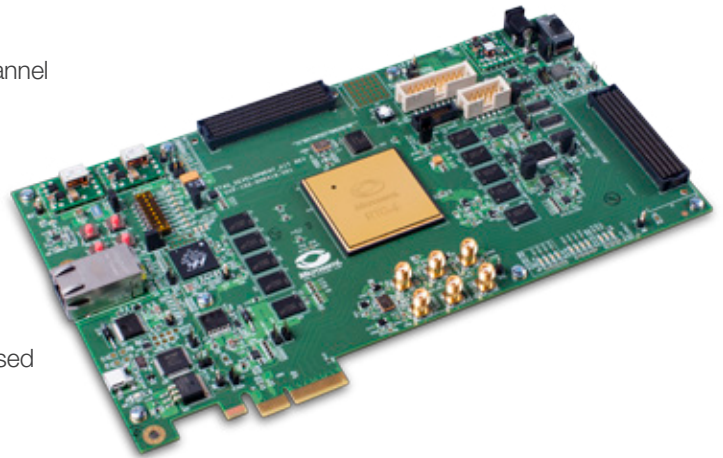

RTG4 Design Software – Libero SoC

Microsemi's **Libero System-on-Chip (SoC)** is a comprehensive software toolset for designing with Microsemi RTG4 FPGAs. Libero SoC manages the entire design flow from design entry, synthesis and simulation, through place-and-route, timing and power analysis, with enhanced integration of the embedded design flow.

Libero SoC Software Features:

- Push button design flow performs synthesis to programming in one click
- Message wizard to find and fix errors faster
- Rich IP library and user-defined block creation flow for design re-use to enable a faster time-to-market and a lesser development cost
- Synplify Pro ME synthesis fully optimizes Microsemi FPGA device performance and area utilization
- Symphony Model Compiler ME performs high-level synthesis optimizations within a Simulink® environment
- Modelsim ME VHDL or Verilog behavioral, post-synthesis and post-layout simulation capability
- Identify to probe and debug your FPGA design directly in the source RTL
- Timing-driven and power-driven place-and-route
- SmartTime environment for timing constraint management and analysis
- SmartPower provides comprehensive power analysis for actual and “what if” power scenarios

For Prototyping and Daisy-chained packages – please refer to pages 17 & 18 of this brochure.



Intellectual Property Cores for System Critical FPGAs

Microsemi has more than 180 intellectual property (IP) products designed and optimized to support communications, consumer, military, industrial, automotive and aerospace markets. Microsemi IP solutions streamline designs, enable faster time-to-market and minimize design costs and risk. Microsemi IP cores are accessible through the Microsemi Libero IDE suite of development tools via the SmartDesign IP design interface. Many Microsemi cores feature firmware drivers accessible through the Firmware Catalog tool. Integrated solutions are also available, featuring Microsemi IP and highlighting the advantages of Microsemi's intrinsically low power FPGAs. A few key IP cores for system critical applications are shown below, and the entire library of cores is available at www.microsemi.com/products/fpga-soc/design-resources/ip-cores.

MIL-STD-1553B IP Cores

MIL-STD-1553 is a command/response, dual-redundant, time-multiplexed serial data bus used in severe environments. Microsemi Core1553 IP cores provide robust, fully tested MIL-STD-1553A and B implementations that are compatible with legacy 1553 solutions. Microsemi provides everything needed to incorporate one or more 1553B cores into a system design. Core1553BRM, Core1553BRT, Core1553BRT-EBR and Core1553BBC are available.

Core1553BRM

- Compliant to MIL-STD-1553A and B
- Bus Controller (BC), Remote Terminal (RT) and Monitor Terminal (MT)
- Simultaneous RT/MT operation
- 12, 16, 20 or 24 MHz clock operation
- Built-in test capability
- Advanced RT functions
- Sophisticated BC reduces host overhead
- Interfaces to standard transceivers
- Redundancy for severe environments
- Low power operation

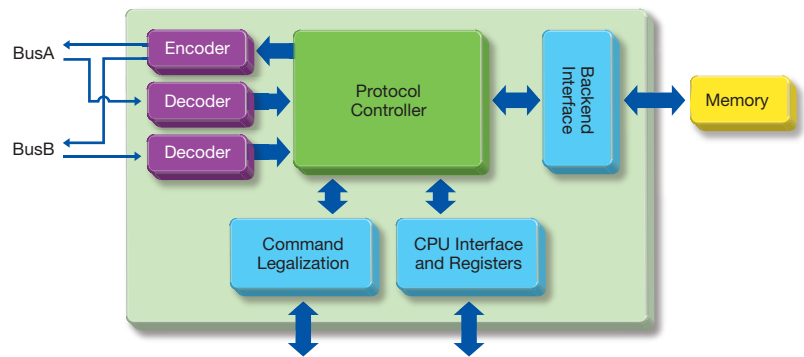

Digital Signal Processing IP Cores

Microsemi digital signal processing (DSP) cores deliver digital filtering and signal processing capabilities. Cores taking advantage of on-chip multiplier blocks in Microsemi's RTAX-DSP and new RTG4 devices offer outstanding performance in spaceflight applications.

CoreFFT

- Highly parameterizable DirectCore RTL generator optimized for the RTAX-DSP and RTG4 families support forward and inverse complex FFT
- Transforms sizes from 32 to 8,192 points
- 8 to 32 bits I/O real and imaginary data and twiddle coefficients
- Two's complement I/O data
- Bit-reversed or natural output order
- Selection of unconditional or conditional block floating point scaling
- Embedded RAM-block-based twiddle LUT
- Built-in memory buffers with optional extensive or minimal memory buffering configurations
- Handshake signals to facilitate easy interface to user circuitry

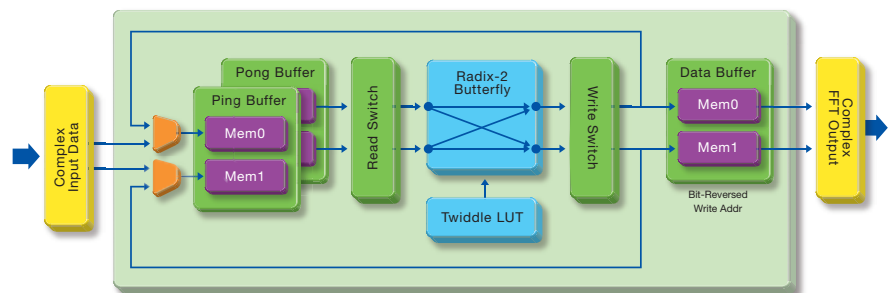

Buffered FFT Block Diagram

CoreFIR

- Highly parameterizable DirectCore RTL generator optimized for the RTAX-DSP and RTG4 families implement a range of filter types, including single rate fully enumerated (parallel), single-rate folded (semi-parallel) filter and multi-rate polyphase interpolation FIR filter
- Performance up to 124 MHz
- Supports up to 1,024 FIR filter taps
- Run-time reloadable coefficients, multiple coefficient sets, or fixed coefficients
- 2-bit to 18-bit input data and coefficient precision
- Signed or unsigned data and coefficients
- Full precision output
- Coefficient symmetry optimization (on the fully enumerated filters)

Prototyping Flows

With the introduction of Microsemi's RTAX-S/SL devices, designers now have access to the most powerful FPGAs available for aerospace and radiation-intensive applications. Prototype verification is an important step in system integration where accurate behavioral simulation and static timing analysis are crucial. Since the enhanced radiation characteristics of radiation-tolerant devices are not required during the prototyping phase of the design, Microsemi has developed various prototyping options for RTAX-S/SL for early design development and functional verification.

Prototyping with Accelerator Units

The prototyping solution using the commercial Accelerator devices consists of two parts:

- A well-documented design flow that allows the customer to target an RTAX-S/SL design to the equivalent commercial Accelerator device
- A set of Microsemi Extender circuit boards that map the commercial device package to the appropriate RTAX-S/SL package footprint

This methodology provides the user with a cost-effective solution while maintaining the short time-to-market associated with Microsemi FPGAs.

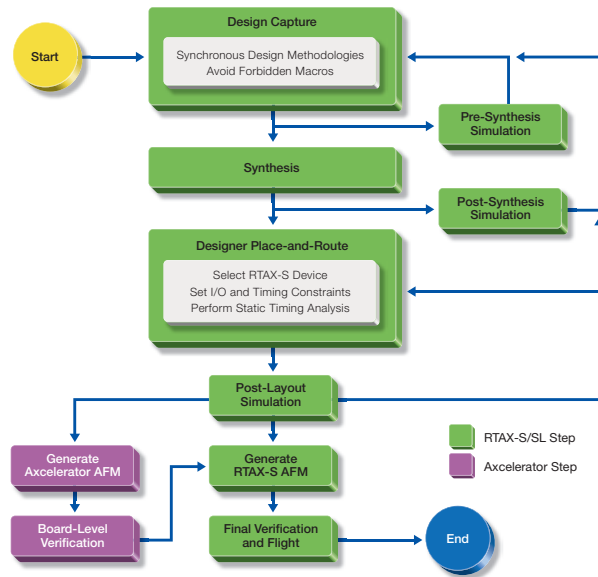

Prototyping with RTAX-S/SL/DSP or RTSX-SU PROTO Units

The RTAX-S/SL/DSP or RTSX-SU PROTO units offer a prototyping solution that can be used for final timing verification of the flight design. The RTAX-S/SL/DSP or RTSX-SU PROTO prototype units have the same timing attributes as the RTAX-S/SL/DSP or RTSX-SU flight units. Prototype units are offered in non-hermetic ceramic packages. The prototype units include "PROTO" in their part number, and "PROTO" is marked on devices to indicate that they are not intended for space flight. They also are not intended for applications that require the quality of spaceflight units, such as qualification of spaceflight hardware. RT-PROTO units offer no guarantee of hermeticity, and no MIL-STD-883B processing. At a minimum, users should plan on using class B level devices for all qualification activities. The RT-PROTO units are electrically tested in a manner to guarantee their performance over the full military temperature range. The RT-PROTO units will also be offered in -1 or standard speed grades, so as to enable customers to validate the timing attributes of their space designs using actual flight silicon.

RTAX-S/SL Prototyping with Flash Devices

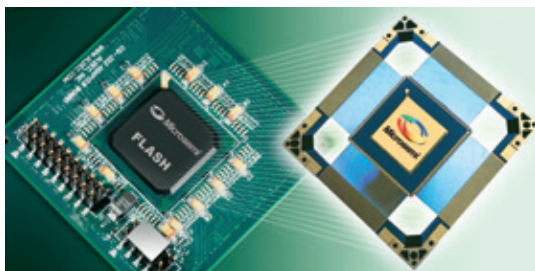

Aldec's RTAX-S/SL prototyping solution allows customers to take advantage of Microsemi's flash-based reprogrammable ProASIC3 devices. Aldec provides software that remaps antifuse primitives to flash, which reduces design time and cost. In addition, the hardware adapter is footprint compatible with RTAX-S/SL; therefore, a customer does not need to redesign a new board for prototyping.

Prototyping Solutions

Prototyping with RTG4 PROTO Units

RTG4 PROTO FPGAs offer a development and prototyping solution that can be used for development and final timing validation of the flight design. As the RTG4 PROTO units use the same reprogrammable Flash technology as the flight units, the PROTO devices can be reprogrammed many times without removing them from the development board. The RTG4 PROTO prototype units have the same timing attributes as the RTG4 flight units, including support for the same speed grades as the flight parts. The RT-PROTO units are electrically tested in a manner to guarantee their performance over the full military temperature range. Prototype units are offered in non-hermetic, ceramic packages. The prototype units include “PROTO” in their part number, and “PROTO” is marked on devices to indicate that they are not intended for space flight. They are also not intended for applications that require the quality of spaceflight units, such as qualification of spaceflight hardware. RT-PROTO units offer no guarantee of hermeticity, and no Mil-STD-883 class B processing. At a minimum, users should plan on using class B devices for all qualification activities.

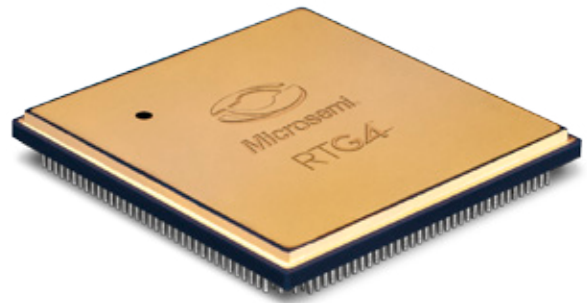

Package Prototyping Solutions

Microsemi has developed multiple low-cost prototyping solutions for RTAX-S/SL devices that ultimately are packaged in CQFP or CCGA for the production system. These solutions utilize Axcelerator family Fine Pitch Ball Grid Array (FBGA) or Ceramic Land Grid Array (CLGA) packages as prototyping vehicles:

- CQFP to FBGA adapter socket
- CQFP to CLGA adapter socket
- CCGA to FBGA adapter socket
- CCGA to CLGA adapter socket

The CQFP to FBGA adapter sockets have an FBGA configuration on the top and a CQFP configuration on the bottom. The adapter sockets enable customers to use a commercial Axcelerator FG package during prototyping, and then switch to an equivalent CQ256 or CQ352 package for production.

Adapter Socket	Ordering Part Number	Prototyped and Prototype Device
CQ352 to FG484	SK-AX250-CQ352RTFG484S	For prototyping RTAX250S/L-CQ352 or AX250-CQ352 using AX250-FG484 package
CQ352 to FG896	SK-AX1-AX2-KITTOP and SK-AX1-CQ352-KITBTM	For prototyping RTAX1000S/L-CQ352 or AX1000-CQ352 using AX1000-FG896 package
CQ352 to FG896	SK-AX1-AX2-KITTOP and SK-AX2-CQ352-KITBTM	For prototyping RTAX2000S/L-CQ352 or AX2000-CQ352 using AX2000-FG896 package
CQ256 to FG896	SH-AX2-CQ256-KITTOP and SK-AX2-CQ256-KITBTM	For prototyping RTAX2000S/L-CQ352 or AX2000-CQ256 using AX2000-FG896 package
CG624 to FG484	SK-SX72-CG624RTFG484	For prototyping RTSX72SU-CG624 or A54SX72A-CG624 using A54SX72A-FG484 package
CG624 to FG896	SK-AX1-AX2-KITTOP and SK-AX1-CG624-KITBTM	For prototyping RTAX1000S-CG624, RTAX1000SL-CG624, or AX1000-CG624 using AX1000-FG896 package
CG624 to FG896	SK-AX1-AX2-KITTOP and SK-AX2-CG624-KITBTM	For prototyping RTAX2000S-CG624, RTAX2000SL-CG624, or AX2000-CG624 using AX2000-FG896 package

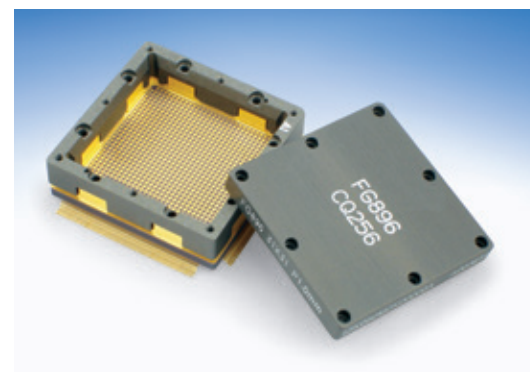

RTAX2000S CQ256 to FG896 Ceramic Adapter, Top and Bottom

Daisy-chained Packages

To facilitate the qualification of target FPGA device socket and board assembly practices without using costly flight-quality parts, Microsemi offers certain Ceramic Column Grid Array (CCGA) and Ceramic Land Grid Array (CLGA) packages with adjacent pairs of pins tied together. By assembling these packages onto a qualification PC board that is laid out with adjacent pairs of solder pads tied together but offset by one pin as compared to the package, a single signal can be fed into one pin of the package and routed into and out of the entire package in a serial daisy chain fashion so all pins of the package are used. This is useful for performing continuity and impedance tests to validate board assembly techniques with surface-mount grid array packages. Microsemi's daisy chain packages feature metal routing tracks between adjacent pairs of package pins, internal to the package. For package qualification, an unbonded silicon die is included in the package.

Microsemi Part Number	Description
LG624 DAISY CHAIN-1	624-pin CLGA mechanical package
LG1152 DAISY CHAIN	1152-pin CLGA mechanical package
LG1272 DAISY CHAIN	1272-pin CLGA mechanical package
LG1657 DAISY CHAIN	1657-pin CLGA mechanical package
CG484 DAISY CHAIN	484-pin CCGA mechanical package
CG624 DAISY CHAIN SIX	624-pin CCGA mechanical package
CG896 DAISY CHAIN	896-pin CCGA mechanical package
CG1152 DAISY CHAIN	1152-pin CCGA mechanical package
CG1272 DAISY CHAIN	1272-pin CCGA mechanical package
CG1657 DAISY CHAIN	1657-pin CCGA mechanical package

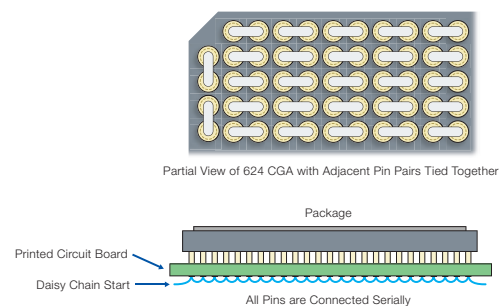

Device Programming



Silicon Sculptor 3

The Silicon Sculptor 3 programmer, which supports both antifuse and flash FPGAs, delivers high data throughput and promotes ease of use, while lowering the overall cost of ownership. The Silicon Sculptor 3 programmer includes a high-speed USB 2.0 interface that enables customers to connect as many as 12 programmers to a single PC. This enables an easily expandable, low to medium volume production programming system to be dynamically assembled. Through the use of universal Microsemi socket adapters, the Silicon Sculptor 3 device programs all Microsemi packages, including PLCC, PQFP, VQFP, TQFP, QFN, PBGA, FBGA, CSP, CPGA, CQFP, CCGA and CLGA.



FlashPro4 and FlashPro5

The FlashPro4 and FlashPro5 programmers for flash FPGAs utilizes a JTAG interface, where a single JTAG chain can be used for multiple Microsemi flash devices on a JTAG chain. In-system programming using the JTAG port adds the flexibility of field upgrades or post-assembly production-line characterization. Production costs are significantly reduced as a result of elimination of expensive sockets on the board.

All FlashPro programmers use JEDEC-standard STAPL files, meaning there are no algorithms built into the software. The FlashPro software and user interface support FlashPro4, FlashPro5 and FlashPro Lite programmers, eliminating the need to learn new software to switch from one hardware programmer to another.

Microsemi is continually adding new products to its industry-leading portfolio.

For the most recent updates to our product line and for detailed information and specifications, please call, email or visit our website:

Toll-free: 800-713-4113

sales.support@microsemi.com

www.microsemi.com

Microsemi makes no warranty, representation, or guarantee regarding the information contained herein or the suitability of its products and services for any particular purpose, nor does Microsemi assume any liability whatsoever arising out of the application or use of any product or circuit. The products sold hereunder and any other products sold by Microsemi have been subject to limited testing and should not be used in conjunction with mission-critical equipment or applications. Any performance specifications are believed to be reliable but are not verified, and Buyer must conduct and complete all performance and other testing of the products, alone and together with, or installed in, any end-products. Buyer shall not rely on any data and performance specifications or parameters provided by Microsemi. It is the Buyer's responsibility to independently determine suitability of any products and to test and verify the same. The information provided by Microsemi hereunder is provided "as is, where is" and with all faults, and the entire risk associated with such information is entirely with the Buyer. Microsemi does not grant, explicitly or implicitly, to any party any patent rights, licenses, or any other IP rights, whether with regard to such information itself or anything described by such information. Information provided in this document is proprietary to Microsemi, and Microsemi reserves the right to make any changes to the information in this document or to any products and services at any time without notice.



Microsemi

Microsemi Corporate Headquarters

One Enterprise, Aliso Viejo, CA 92656 USA

Within the USA: +1 (800) 713-4113

Outside the USA: +1 (949) 380-6100

Sales: +1 (949) 380-6136

Fax: +1 (949) 215-4996

email: sales.support@microsemi.com

www.microsemi.com

Microsemi Corporation (Nasdaq: MSCC) offers a comprehensive portfolio of semiconductor and system solutions for communications, defense & security, aerospace and industrial markets. Products include high-performance and radiation-hardened analog mixed-signal integrated circuits, FPGAs, SoCs and ASICs; power management products; timing and synchronization devices and precise time solutions, setting the world's standard for time; voice processing devices; RF solutions; discrete components; security technologies and scalable anti-tamper products; Ethernet solutions; Power-over-Ethernet ICs and midspans; as well as custom design capabilities and services. Microsemi is headquartered in Aliso Viejo, Calif., and has approximately 3,600 employees globally. Learn more at www.microsemi.com.

©2016 Microsemi Corporation. All rights reserved. Microsemi and the Microsemi logo are registered trademarks of Microsemi Corporation. All other trademarks and service marks are the property of their respective owners.

RTFPGA-1-16

X-ON Electronics

Largest Supplier of Electrical and Electronic Components

Click to view similar products for [Processor Accessories](#) category:

Click to view products by [Microsemi](#) manufacturer:

Other Similar products are found below :

[2447](#) [451651](#) [SPB204-AL-1](#) [90001265-88](#) [32316](#) [MIKROE-2147](#) [20-101-0431](#) [28148](#) [T050000](#) [28961](#) [28960](#) [Basic US PI3 Kit](#)
[82634DSARPLTVIK](#) [1557](#) [20-101-0502](#) [28109](#) [EP-CHUPCNETPLUS](#) [1019](#) [4466](#) [AD-FMC-SDCARD](#) [ATATMEL-ICE-CABLE](#)
[ATATMEL-ICE-PCBA](#) [ATAVR-MICTOR38](#) [Basic INTL PI3 Kit](#) [20-101-0495](#) [BK0006](#) [BK0007](#) [LG624](#) [DAISY CHAIN-1](#) [MIKROE-2094](#)
[MIKROE-2148](#) [MIKROE-2149](#) [130-35000](#) [28106](#) [28152](#) [30055](#) [30078](#) [32333](#) [555-28188](#) [572-28132](#) [CWH-CTP-STC-YE](#) [910-28015B](#)
[ATABOT](#) [700-00056](#) [FXX-3006-JES](#) [28114](#) [28985](#) [868](#) [1744](#) [ARX-DSP](#) [B000003](#)