

**VOIDLESS-HERMETICALLY-SEALED
SURFACE MOUNT STANDARD
RECOVERY GLASS RECTIFIERS**

DESCRIPTION

This "standard recovery" surface mount rectifier diode series is military qualified to MIL-PRF-19500/427 and is ideal for high-reliability applications where a failure cannot be tolerated. These industry-recognized 1.0 Amp rated rectifiers for working peak reverse voltages from 200 to 1000 volts are hermetically sealed with voidless-glass construction using an internal "Category I" metallurgical bond. These devices are also available in axial-led thru-hole package configurations (see separate data sheet for 1N5614 thru 1N5622). Microsemi also offers numerous other rectifier products to meet higher and lower current ratings with various recovery time speed requirements including fast and ultrafast device types in both through-hole and surface mount packages.

APPEARANCE

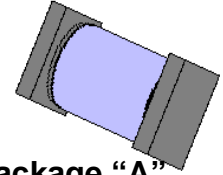

**Package "A"
or D-5A**

IMPORTANT: For the most current data, consult MICROSEMI's website: <http://www.microsemi.com>

FEATURES

- Surface mount package series equivalent to the JEDEC registered 1N5614 to 1N5622 series
- Voidless hermetically sealed glass package
- Triple-Layer Passivation
- Internal "Category I" Metallurgical bonds
- Working Peak Reverse Voltage 200 to 1000 Volts.
- JAN, JANTX, JANTXV, and JANS available per MIL-PRF-19500/427
- Axial-led equivalents also available (see separate data sheet for 1N5614 thru 1N5622)

APPLICATIONS / BENEFITS

- Standard recovery 1 Amp rectifiers 200 to 1000 V
- Military and other high-reliability applications
- General rectifier applications including bridges, half-bridges, catch diodes, etc.
- High forward surge current capability
- Extremely robust construction
- Low thermal resistance
- Controlled avalanche with peak reverse power capability
- Inherently radiation hard as described in Microsemi MicroNote 050

MAXIMUM RATINGS

- Junction & Storage Temperature: -65°C to +200°C
- Thermal Resistance: 13°C/W junction to end cap
- Thermal Impedance: 4.5°C/W @ 10 ms heating time
- Average Rectified Forward Current (I_O): 1.0 Amps @ T_A = 55°C and 0.75 Amps @ T_A = 100°C
- Forward Surge Current: 30 Amps @ 8.3 ms half-sine
- Solder Temperatures: 260°C for 10 s (maximum)

MECHANICAL AND PACKAGING

- CASE: Hermetically sealed voidless hard glass with Tungsten slugs
- TERMINALS: End caps are Copper with Tin/Lead (Sn/Pb) finish. Note: Previous inventory had solid Silver end caps with Tin/Lead (Sn/Pb) finish.
- MARKING & POLARITY: Cathode band only
- TAPE & REEL option: Standard per EIA-481-B
- WEIGHT: 193 mg
- See package dimensions and recommended pad layout on last page

ELECTRICAL CHARACTERISTICS

TYPE	WORKING PEAK REVERSE VOLTAGE V _{RWM}	MINIMUM BREAKDOWN VOLTAGE V _{BR} @ 50μA	AVERAGE RECTIFIED CURRENT I _O @ T _A (NOTE 1)		FORWARD VOLTAGE (MAX.) V _F @ 3A	REVERSE CURRENT (MAX.) I _R @ V _{RWM}		MAXIMUM SURGE CURRENT I _{FSM} (NOTE 2)	REVERSE RECOVERY (NOTE 3) t _{rr}
			AMPS			μA			
			55°C	100°C		25°C	100°C		
1N5614US	200	220	1.00	.750	0.8 MIN.	0.5	25	30	2.0
1N5616US	400	440	1.00	.750		0.5	25	30	2.0
1N5618US	600	660	1.00	.750	1.3 MAX.	0.5	25	30	2.0
1N5620US	800	880	1.00	.750		0.5	25	30	2.0
1N5622US	1000	1100	1.00	.750		0.5	25	30	2.0

NOTE 1: From 1 Amp at T_A = 55°C, derate linearly at 5.56 mA/°C to 0.75 Amp at T_A = 100°C. From T_A = 100°C, derate linearly at 7.5 mA/°C to 0 Amps at T_A = 200°C. These ambient ratings are for PC boards where thermal resistance from mounting point to ambient is sufficiently controlled where T_{J(max)} does not exceed 175°C.

NOTE 2: T_A = 100°C, f = 60 Hz, I_O = 750 mA for ten 8.3 ms surges @ 1 minute intervals

NOTE 3: I_F = 0.5A, I_{RM} = 1A, I_{R(REC)} = 0.250A

SYMBOLS & DEFINITIONS

Symbol	Definition
V_{BR}	Minimum Breakdown Voltage: The minimum voltage the device will exhibit at a specified current.
V_{RWM}	Working Peak Reverse Voltage: The maximum peak voltage that can be applied over the operating temperature range.
V_F	Maximum Forward Voltage: The maximum forward voltage the device will exhibit at a specified current.
I_R	Maximum Leakage Current: The maximum leakage current that will flow at the specified voltage and temperature.
C	Capacitance: The capacitance in pF at a frequency of 1 MHz and specified voltage
t_{rr}	Reverse Recovery Time: The time interval between the instant the current passes through zero when changing from the forward direction to the reverse direction and a specified decay point after a peak reverse current occurs.

GRAPHS

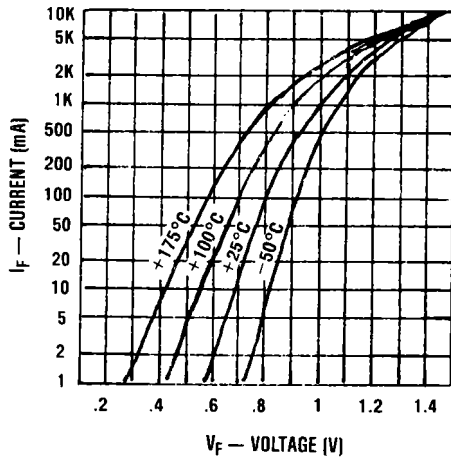

FIGURE 1
TYPICAL FORWARD VOLTAGE vs FORWARD CURRENT

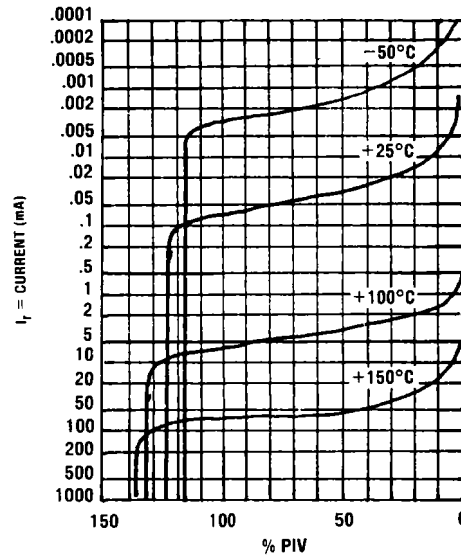
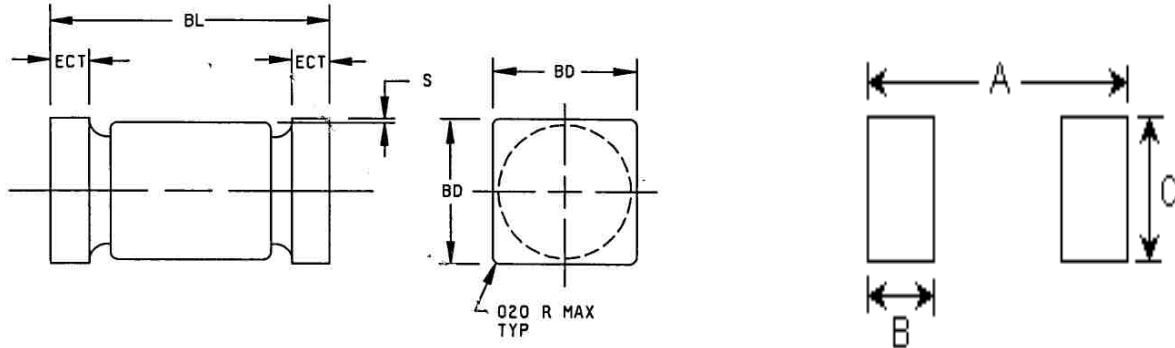

FIGURE 2
TYPICAL REVERSE CURRENT vs PIV

PACKAGE DIMENSIONS AND PAD LAYOUT



NOTE: This Package Outline has also previously been identified as "D-5A"

	INCHES		mm	
	MIN	MAX	MIN	MAX
BD	.097	.103	2.46	2.62
BL	.185	.200	4.70	5.08
ECT	.019	.028	0.48	0.71
S	.003	---	0.08	---

PAD LAYOUT

	INCHES	mm
A	0.246	6.25
B	0.067	1.70
C	0.105	2.67

Note: If mounting requires adhesive separate from the solder, an additional 0.060 inch diameter contact may be placed in the center between the pads as an optional spot for cement.

X-ON Electronics

Largest Supplier of Electrical and Electronic Components

Click to view similar products for [Rectifiers](#) category:

Click to view products by [Microsemi](#) manufacturer:

Other Similar products are found below :

[70HFR40](#) [RL252-TP](#) [150KR30A](#) [1N5397](#) [NTE5841](#) [NTE6038](#) [SCF5000](#) [1N4002G](#) [1N4005-TR](#) [JANS1N6640US](#) [481235F](#)
[RRE02VS6SGTR](#) [067907F](#) [MS306](#) [70HF40](#) [T85HFL60S02](#) [US2JFL-TP](#) [A1N5404G-G](#) [ACGRA4007-HF](#) [ACGRB207-HF](#)
[CLH03\(Te16L,Q\)](#) [ACGRC307-HF](#) [ACEFC304-HF](#) [NTE6356](#) [NTE6359](#) [NTE6002](#) [NTE6023](#) [NTE6039](#) [NTE6077](#) [85HFR60](#) [40HFR60](#)
[70HF120](#) [85HFR80](#) [D126A45C](#) [SCF7500](#) [D251N08B](#) [SCHJ22.5K](#) [SM100](#) [SCPA2](#) [SCH10000](#) [SDHD5K](#) [VS-12FL100S10](#) [ACGRA4001-](#)
[HF](#) [D1821SH45T PR](#) [D1251S45T](#) [NTE5990](#) [NTE6358](#) [NTE6162](#) [NTE5850](#) [SKN300/16](#)