

NPN LOW POWER SILICON TRANSISTOR

Qualified per MIL-PRF-19500/301

DEVICES

2N918 2N918UB

**LEVELS
 JAN
 JANTX
 JANTXV**

ABSOLUTE MAXIMUM RATINGS ($T_C = +25^\circ\text{C}$ unless otherwise noted)

Parameters / Test Conditions	Symbol	Value	Unit
Collector-Emitter Voltage	V_{CEO}	15	Vdc
Collector-Base Voltage	V_{CBO}	30	Vdc
Emitter-Base Voltage	V_{EBO}	3.0	Vdc
Collector Current	I_C	50	mAdc
Total Power Dissipation @ $T_A = +25^\circ\text{C}$ ⁽¹⁾	P_T	200	mW
Operating & Storage Junction Temperature Range	T_{op} & T_{stg}	-65 to +200	$^\circ\text{C}$

Note: 1) Derate linearly 1.14mW/ $^\circ\text{C}$ above $T_A > 25^\circ\text{C}$

ELECTRICAL CHARACTERISTICS ($T_A = +25^\circ\text{C}$, unless otherwise noted)

Parameters / Test Conditions	Symbol	Min.	Max.	Unit
OFF CHARACTERISTICS				
Collector-Emitter Breakdown Voltage $I_C = 3\text{mAdc}$	$V_{(BR)CEO}$	15		Vdc
Collector-Base Cutoff Current $V_{CB} = 30\text{Vdc}$ $V_{CB} = 25\text{Vdc}$ $V_{CB} = 25\text{Vdc}; T_A = +150^\circ\text{C}$	I_{CBO}		1.0 10 1.0	μAdc ηAdc μAdc
Emitter-Base Cutoff Current $V_{EB} = 3.0\text{Vdc}$ $V_{EB} = 2.5\text{Vdc}$	I_{EBO}		10 10	μAdc ηAdc
Forward-Current Transfer Ratio $I_C = 0.5\text{mAdc}, V_{CE} = 10\text{Vdc}$ $I_C = 3.0\text{mAdc}, V_{CE} = 1.0\text{Vdc}$ $I_C = 10\text{mAdc}, V_{CE} = 10\text{Vdc}$ $I_C = 3.0\text{mAdc}, V_{CE} = 1.0\text{Vdc}; T_A = -55^\circ\text{C}$	h_{FE}	10 20 20 10	200	
Collector-Emitter Saturation Voltage $I_C = 10\text{mAdc}, I_B = 1.0\text{mAdc}$	$V_{CE(sat)}$		0.4	Vdc
Base-Emitter Voltage $I_C = 10\text{mAdc}, I_B = 1.0\text{mAdc}$	$V_{BE(sat)}$		1.0	Vdc

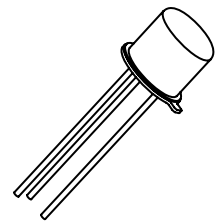

**TO-72
 2N918**

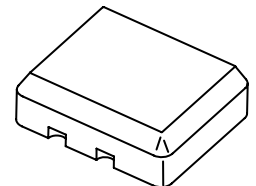

**3 PIN
 2N918UB**

DYNAMIC CHARACTERISTICS

Parameters / Test Conditions	Symbol	Min.	Max.	Unit
Magnitude of Small-Signal Short-Circuit - Forward Current Transfer Ratio $I_C = 4\text{mA}$, $V_{CE} = 10\text{Vdc}$, $f = 100\text{MHz}$	$ h_{fe} $	6.0	18	
Output Capacitance $V_{CB} = 0\text{Vdc}$, $I_E = 0$, $100\text{kHz} \leq f \leq 1.0\text{MHz}$ $V_{CB} = 10\text{Vdc}$, $I_E = 0$, $100\text{kHz} \leq f \leq 1.0\text{MHz}$	C_{obo1} C_{obo2}		3.0 1.7	pF
Input Capacitance $V_{EB} = 0.5\text{Vdc}$, $I_C = 0$, $100\text{kHz} \leq f \leq 1.0\text{MHz}$	C_{ibo}		2.0	pF
Noise Figure (1) $V_{CE} = 6\text{V}$, $I_C = 1.0\text{mA}$, $f = 60\text{MHz}$ $g_s = 2.5\text{mmho}$	NF		6.0	dB
Small-Signal Power Gain (1) $V_{CB} = 12\text{V}$, $I_C = 6.0\text{mA}$, $f = 200\text{MHz}$	G_{pe}	15		dB
Collector-Base Time Constant (1) $V_{CB} = 10\text{V}$, $I_E = -4.0\text{mA}$, $f = 79.8\text{MHz}$	$R_{b'CC}$		25	ps
Oscillator Power Output (1) $V_{CB} = 1.5\text{V}$, $I_C = 8.0\text{mA}$, $f \geq 500\text{MHz}$	P_o	30		mW
Collector Efficiency $V_{CB} = 15\text{V}$, $I_C = 8.0\text{mA}$, $f > 500\text{MHz}$	η	25		%

NOTES:

(1) For more detail see MIL-PRF-19500/301

PACKAGE DIMENSIONS

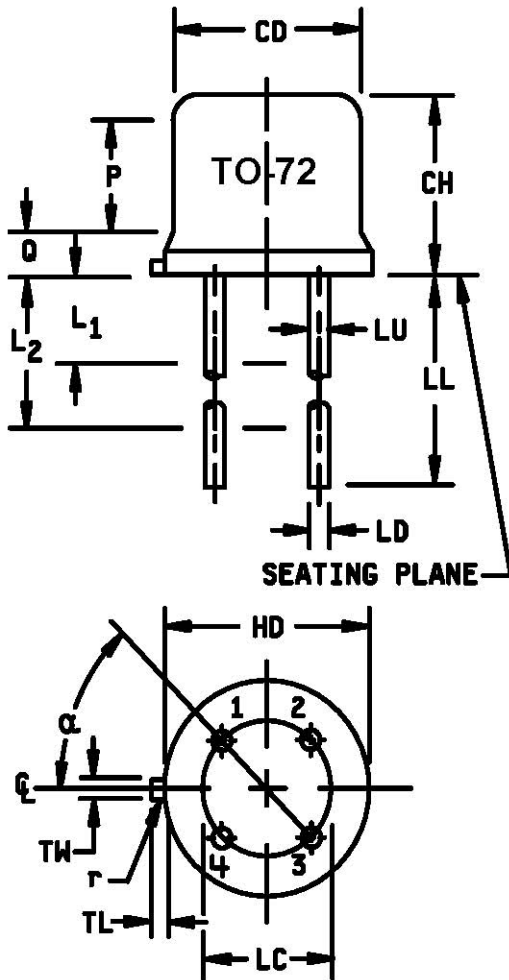

Symbol	Dimensions				Note
	Inches		Millimeters		
	Min	Max	Min	Max	
CD	.178	.195	4.52	4.95	5
CH	.170	.210	4.32	5.33	
HD	.209	.230	5.31	5.84	5
LC	.100 TP		2.54 TP		7,8
LD	.016	.021	.406	.533	7,8
LL	.500	.750	12.70	19.05	7,8
LU	.016	.019	.406	.483	
L1		.050		1.27	
L2	.250		6.35		
P	.100		2.54		
Q		.040		1.02	5
TL	.028	.048	.71	1.22	
TW	.036	.046	.91	1.17	
r		.007		.18	
α	45° TP				

NOTES:

1. Dimension are in inches.
2. Millimeters are given for general information only.
3. Beyond r (radius) maximum, TH shall be held for a minimum length of .011 inch (0.28 mm).
4. Dimension TL measured from maximum HD.
5. Body contour optional within zone defined by HD, CD, and Q.
6. Leads at gauge plane $.054 +.001 - .000$ inch ($1.37 +0.025 -0.00$ mm) below seating plane shall be within .007 inch (0.18mm) radius of true position (TP) at maximum material condition (MMC) relative to tab at MMC.
7. Dimension LU applies between L1 and L2. Dimension LD applies between L2 and LL minimum. Diameter is uncontrolled in L1 and beyond LL minimum.
8. All four leads.
9. Dimension r (radius) applies to both inside corners of tab.
10. In accordance with ASME Y14.5M, diameters are equivalent to ϕx symbology.
11. Lead 1 = emitter, lead 2 = base, lead 3 = collector, lead 4 = case (electrically connected).

FIGURE 1. Physical dimensions for 2N918 (TO-72).

PACKAGE DIMENSIONS

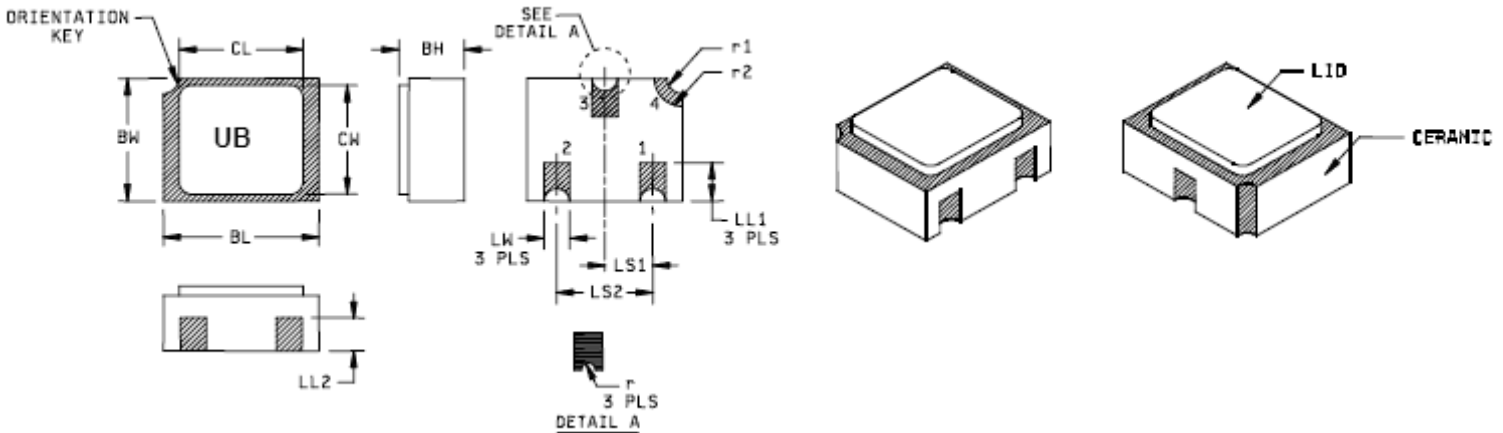

Symbol	Dimensions				Note
	Inches		Millimeters		
	Min	Max	Min	Max	
BH	.046	.056	1.17	1.42	
BL	.115	.128	2.92	3.25	
BW	.085	.108	2.16	2.74	
CL		.128		3.25	
CW		.108		2.74	
LL ₁	.022	.038	0.56	0.97	
LL ₂	.017	.035	0.4	0.89	

Symbol	Dimensions				Note
	Inches		Millimeters		
	Min	Max	Min	Max	
LS ₁	.036	.040	0.91	1.02	
LS ₂	.071	.079	1.80	2.01	
LW	.016	.024	0.41	0.61	
r		.008		.203	
r1		.012		.305	
r2		.022		.559	

NOTES:

1. Dimensions are in inches.
2. Millimeters are given for general information only.
3. Hatched areas on package denote metallized areas.
4. Lid material: Kovar.
5. Pad 1 = Base, Pad 2 = Emitter, Pad 3 = Collector, Pad 4 = Shielding connected to the lid.
6. In accordance with ASME Y14.5M, diameters are equivalent to ϕx symbology.

FIGURE 2. Physical dimensions for 2N918UB, surface mount.

X-ON Electronics

Largest Supplier of Electrical and Electronic Components

Click to view similar products for [Bipolar Transistors - BJT category](#):

Click to view products by [Microsemi manufacturer](#):

Other Similar products are found below :

[619691C](#) [MCH4017-TL-H](#) [BC546/116](#) [BC557/116](#) [BSW67A](#) [NTE158](#) [NTE187A](#) [NTE195A](#) [NTE2302](#) [NTE2330](#) [NTE63](#) [C4460](#)
[2SA1419T-TD-H](#) [2SA1721-O\(TE85L,F\)](#) [2SA2126-E](#) [2SB1204S-TL-E](#) [2SC5488A-TL-H](#) [2SD2150T100R](#) [SP000011176](#) [FMMTA92QTA](#)
[2N2369ADCSM](#) [2SC2412KT146S](#) [2SC5490A-TL-H](#) [2SD1816S-TL-E](#) [2SD1816T-TL-E](#) [CMXT2207 TR](#) [CPH6501-TL-E](#) [MCH4021-TL-E](#)
[US6T6TR](#) [732314D](#) [CMXT3906 TR](#) [CPH3121-TL-E](#) [CPH6021-TL-H](#) [873787E](#) [UMX21NTR](#) [EMT2T2R](#) [MCH6102-TL-E](#) [FP204-TL-E](#)
[NJL0302DG](#) [2N3583](#) [2SA1434-TB-E](#) [2SC3143-4-TB-E](#) [2SD1621S-TD-E](#) [NTE103](#) [30A02MH-TL-E](#) [NSV40301MZ4T1G](#) [NTE101](#) [NTE13](#)
[NTE15](#) [NTE16001](#)