

# LX3301A Inductive Sensor Interface IC with Embedded MCU

## Description

The LX3301A is a member of Microsemi’s new family of smart sensor interface products. Designed to process inductive sensors, which are based upon linear variable differential transformer (LVDT) principles, this new device integrates two complete analog channels, oscillator/exciter, 32-bit RISC processor, non-volatile configuration memory, and analog or PWM outputs.

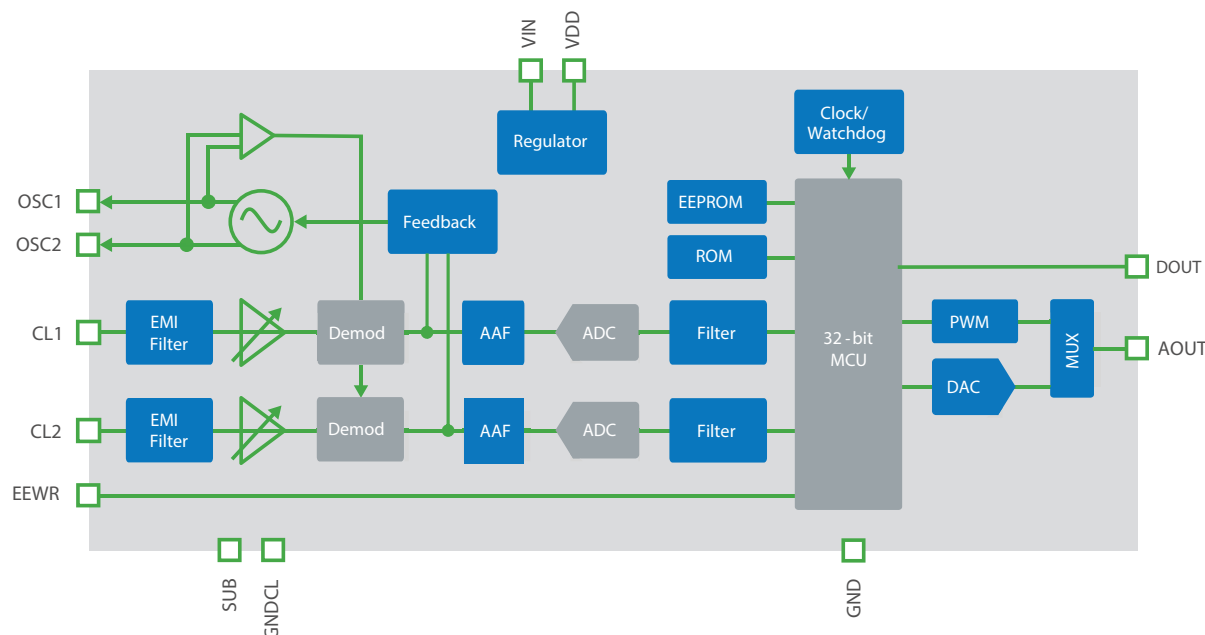

Figure 1: Top-Level Block Diagram

In typical operation, inputs from the inductive sensor are conditioned, demodulated, and converted into 13-bit values. The MCU processes these values to produce a linearized measurement value with either 12-bit accuracy (analog output) or 13-bit accuracy (PWM output.) Internal non-volatile memory allows the user to configure various parameters within the IC, including five (5) calibration points, origin/end points, and low and high plateau levels. The internal non-volatile memory is configured via the VIN power pin, which allows a sensor assembly to be configured without the need for additional programming pins.

## Key Features

- Embedded 32-bit processing engine with 12 kB program memory
- Two sensor input channels with integrated demodulator
- Internal oscillator with frequency range of 1 to 5 MHz
- Dual 13-bit ADC with sample rates to 2 kHz
- Linearization algorithm with:
  - o Five user-defined linearization points
  - o Programmable origin and end points
  - o 6 segments linearization
  - o Programmable low and high plateau levels
- User-programmable 16 x 16-bit non-volatile configuration memory
- Multiple diagnostics features (ISO 26262 compliant)
- Host interface: Analog output or PWM
- 4.5 V to 5.6 V input voltage; 8 mA (typical) operating current, not including exciter tail current
- -40 to 125 °C operation, AEC-Q100 grade 1 certified

# LX3301A Inductive Sensor Interface IC with Embedded MCU

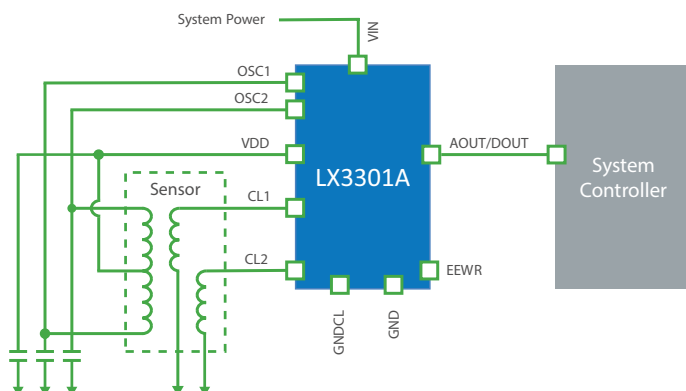

**Figure 2:** LVDT/Inductive Sensor Configuration

The LX3301A includes integrated diagnostics features, which regularly monitor various functions within the IC and report conditions which are outside of specified parameters. In the event of a detect failure, the device drives the output to a pre-defined diagnostics level. The internal diagnostics information can also be output via SENT-compatible protocol for system development and debug purposes.

The LX3301A is compliant with ISO 26262 and rated for ASIL C applications. Packaged in a 14-TSSOP package, the device operates (to specification) from -40 to 125 °C and maintains full functionality to 150 °C. The LX3301A is certified to AEC-Q100 grade 1.

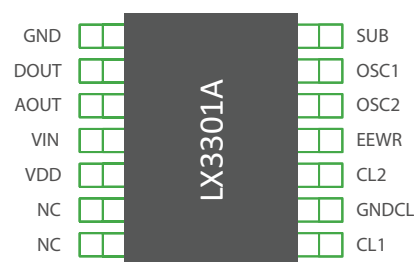

**Figure 3:** 14-TSSOP Pin Assignments

## Target Applications

The LX3301A is an ideal solution for measuring mechanical movement (linear, angular/rotation, and proximity) in a wide variety of applications in automotive, industrial, aerospace, and commercial applications including:

- Rotor position sensing (brushless DC motors)
- Robotic arm positioning
- Fluid level sensing
- Proximity detection (industrial automation)
- Gear position/travel (automotive)

For more information about Microsemi's product portfolio for automotive and industrial applications, visit

<http://www.microsemi.com/applications/automotive>

<http://www.microsemi.com/applications/industrial>

Microsemi makes no warranty, representation, or guarantee regarding the information contained herein or the suitability of its products and services for any particular purpose, nor does Microsemi assume any liability whatsoever arising out of the application or use of any product or circuit. The products sold hereunder and any other products sold by Microsemi have been subject to limited testing and should not be used in conjunction with mission-critical equipment or applications. Any performance specifications are believed to be reliable but are not verified, and Buyer must conduct and complete all performance and other testing of the products, alone and together with, or installed in, any end-products. Buyer shall not rely on any data and performance specifications or parameters provided by Microsemi. It is the Buyer's responsibility to independently determine suitability of any products and to test and verify the same. The information provided by Microsemi hereunder is provided "as is, where is" and with all faults, and the entire risk associated with such information is entirely with the Buyer. Microsemi does not grant, explicitly or implicitly, to any party any patent rights, licenses, or any other IP rights, whether with regard to such information itself or anything described by such information. Information provided in this document is proprietary to Microsemi, and Microsemi reserves the right to make any changes to the information in this document or to any products and services at any time without notice.



**Microsemi**

Microsemi Corporate Headquarters  
 One Enterprise, Aliso Viejo, CA 92656 USA  
 Within the USA: +1 (800) 713-4113  
 Outside the USA: +1 (949) 380-6100  
 Sales: +1 (949) 380-6136  
 Fax: +1 (949) 215-4996  
 email: sales.support@microsemi.com  
 www.microsemi.com

Microsemi Corporation (Nasdaq: MSCC) offers a comprehensive portfolio of semiconductor and system solutions for communications, defense & security, aerospace and industrial markets. Products include high-performance and radiation-hardened analog mixed-signal integrated circuits, FPGAs, SoCs and ASICs; power management products; timing and synchronization devices and precise time solutions, setting the world's standard for time; voice processing devices; RF solutions; discrete components; security technologies and scalable anti-tamper products; Ethernet solutions; Power-over-Ethernet ICs and midspans; as well as custom design capabilities and services. Microsemi is headquartered in Aliso Viejo, Calif., and has approximately 3,600 employees globally. Learn more at [www.microsemi.com](http://www.microsemi.com).

©2015 Microsemi Corporation. All rights reserved. Microsemi and the Microsemi logo are registered trademarks of Microsemi Corporation. All other trademarks and service marks are the property of their respective owners.

## X-ON Electronics

Largest Supplier of Electrical and Electronic Components

*Click to view similar products for [Sensor Interface](#) category:*

*Click to view products by [Microsemi](#) manufacturer:*

Other Similar products are found below :

[ZSC31150GEG1-T](#) [ZSSC4161BE2W](#) [LM1815MX/NOPB](#) [MAX31850KATB+](#) [FM-252-4](#) [FM-215-8](#) [FM-216-AR2](#) [FM-253-4-P](#) [AS8510-ASSM](#) [AD598JRZ](#) [AD598SD/883B](#) [743478D](#) [AD698APZ](#) [AD698SQ](#) [ADA4558WHCPZ-R7](#) [ADPD4000BCBZR7](#) [ADPD4001BCBZR7](#) [MAX31855SASA+](#) [MAX31855TASA+](#) [DRV401AIDWPR](#) [AS89010](#) [MAX31855SASA+T](#) [MAX1358BETL+](#) [MAX31855EASA+](#) [MAX31855KASA+](#) [MAX31855NASA+](#) [MAX31911AUI+](#) [RE46C803SS20](#) [MAX1452AAE+](#) [MAX9926UAEE+](#) [RE46C800SS20](#) [SSC7102-GQ-AB2](#) [MAX6675ISA+](#) [MAX6674ISA+](#) [MAX31855RASA+](#) [MAX6675ISA+T](#) [FM-252-4-P](#) [SNJ306](#) [ZSSC4132CE4W](#) [BD9251FV-E2](#) [XTR110KU](#) [LM1815M/NOPB](#) [PGA302EPWT](#) [PGA308AIDRKT](#) [PGA309AIPWR](#) [RCV420JP](#) [TDC7200PWR](#) [XTR106UA/2K5](#) [TPIC8101DW](#) [TPIC8101DWR](#)