



Microsemi

Description

The LX7176A is a 4A step-down regulator with integrated MOSFETs packaged in a space saving QFN12 2mm x 2mm for today's mobile devices. It uses an ultra fast, constant frequency hysteretic control method to minimize external filter components while maintaining excellent regulation. The LX7176A reference voltage is 0.6V.

The LX7176A operates from 3V to 5.5V rails and outputs 0.6V to 100% of the input voltage.

Cycle-by-cycle current limiting protects against over-current conditions. Hiccup mode provides protection for heavy over-load or short-circuit faults. Thermal protection shuts down the regulator under over-temperature conditions. Over voltage conditions will immediately shut off the output to protect against permanent damage. The LX7176A automatically restarts when all fault conditions are cleared. Internal soft start circuitry limits start up inrush currents.

Features

- ◆ 0-4A Step-down Regulator
- ◆ Operational Input Supply Voltage Range: 3V-5.5V (short durations to 6.5V.)
- ◆ Hysteretic control offers best transient response
- ◆ CCM switching at a constant 1.65MHz
- ◆ Automatically switches to DCM switching under light loads to improve efficiency
- ◆ 100% Duty Ratio Operation
- ◆ Input under voltage and over voltage protection
- ◆ Enable and Power Good Function
- ◆ Internal soft-start
- ◆ Cycle-by-Cycle Over Current Protection
- ◆ Hiccup Mode protects against short circuit faults
- ◆ RoHS Compliant

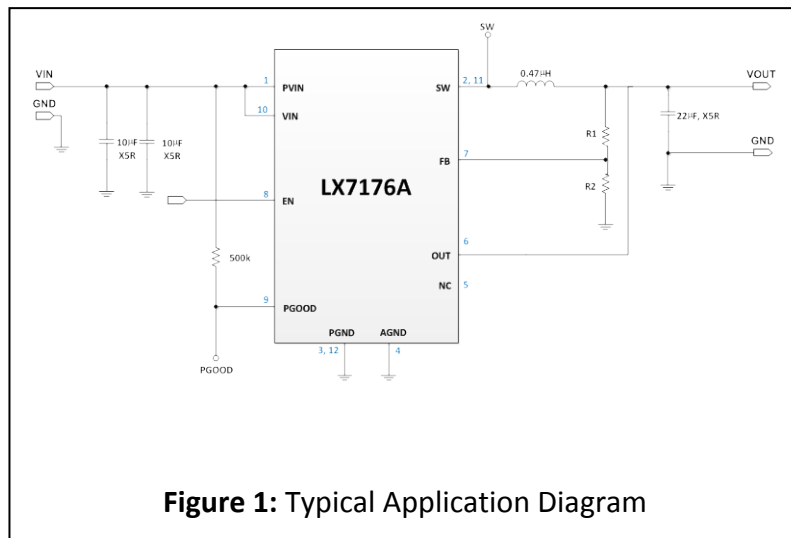

Figure 1: Typical Application Diagram

Applications

- High Performance HDD
- LCD TV
- Notebook/Netbook
- Server and Workstations
- Video Cards
- PoE Powered Devices Smart Phone

Microsemi

Pin Configuration and Pinout

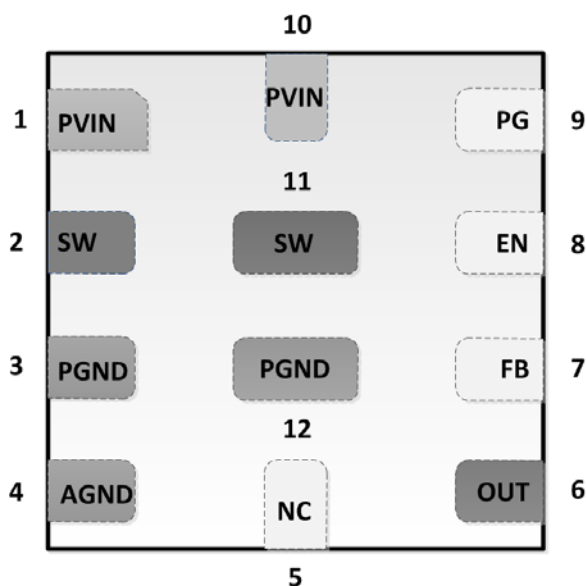

**LX7176A
Top View**

• 76A
YWWL

- Pin 1 Indicator, YWWL = Year/Week/Lot Code
- RoHS / Pb-free Matte Tin Pin Finish

Figure 2: Pinout

Ordering Information

Ambient Temperature	Type	Package	Part Number	Packaging Type
0°C to 85°C	RoHS compliant, Pb-free	QFN 2x2mm 12L	LX7176ACLQ	Bulk
			LX7176ACLQ-TR	Tape and Reel

Thermal Properties

Thermal Resistance(θ_{JA})	Typ	Units
QFN 2x2mm 12L	30	°C/W

Note: The θ_{JA} number assumes no forced airflow. Junction Temperature is calculated using $T_J = T_A + (P_D \times \theta_{JA})$. In particular, θ_{JA} is a function of the PCB construction. The stated number above is for a four-layer board in accordance with JEDEC-51 (JEDEC).

**Microsemi**[®]

Pin Description

Pin Number	Pin Designator	Description
1, 10	PVIN	Supply Voltage. Bypass PVIN to ground plane as close as possible to the IC.
2, 11	SW	Switch Output. Drives the external L-C filter.
3, 12	PGND	Power Ground. Connect to ground plane.
4	AGND	Analog Ground. Connect to ground plane.
5	NC	No connect pin. Leave floating. Serves as SCL when accessing the serial port.
6	OUT	Output Voltage Sense Pin – This pin monitors the output voltage. Serves as SDA when accessing the serial port. Digital signals at this pin will be capacitively coupled onto FB and disturb the output voltage.
7	FB	Feedback – Analog input, monitors the output voltage either directly or through a resistor divider.
8	EN	Enable – Digital input. Force high to enable the IC.
9	PG	Power Good – Open drain digital output. Pulls low to indicate a fault condition. Requires an external pull up resistor. Also used to monitor selected internal signals.



Microsemi

Block Diagram

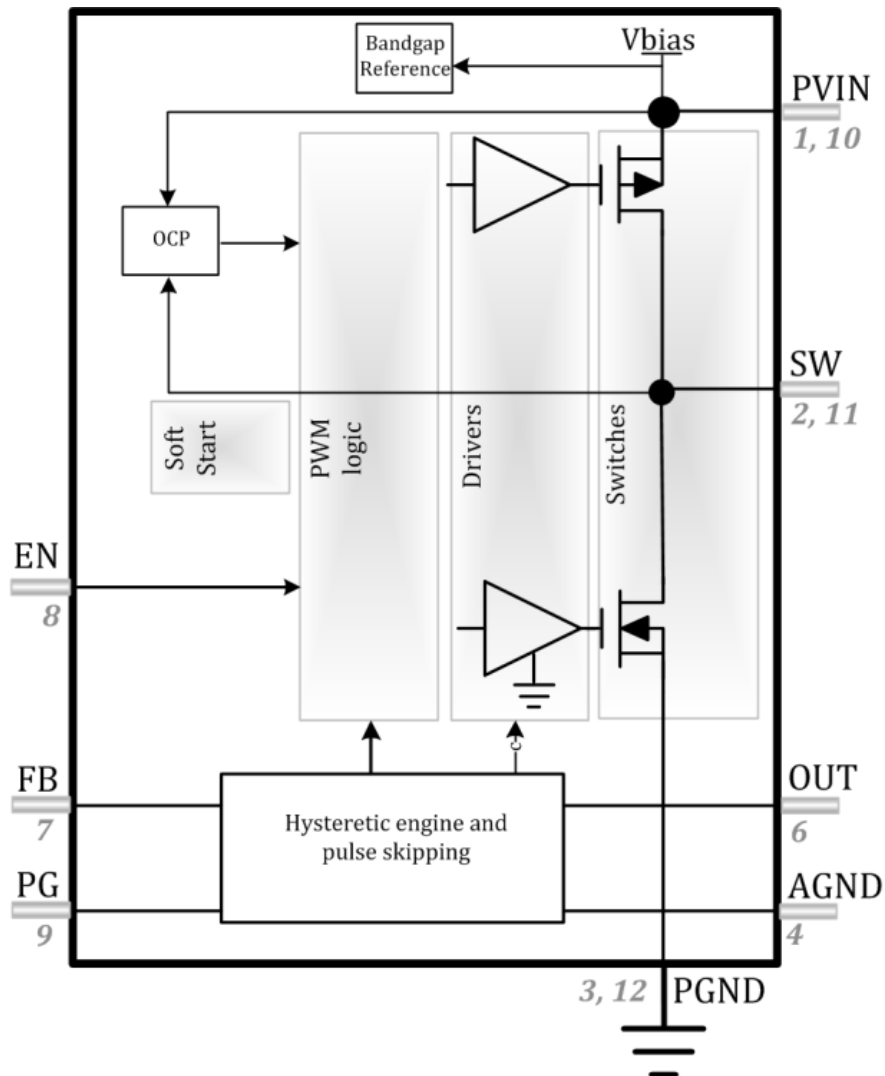

Figure 3: Block Diagram

Microsemi®

Absolute Maximum Ratings

Performance is not necessarily guaranteed over this entire range. These are maximum stress ratings only. Exceeding these ratings, even momentarily, can cause immediate damage, or negatively impact long-term operating reliability.

Parameter	Min	Max	Units
PVIN, EN, PG, OUT, FB, SW to PGND	-0.3	7	V
AGND to PGND	-0.3	0.3	V
SW to PGND (Shorter than 50ns)	-2	7	V
Junction Temperature Range	0	150	°C
Storage Temperature Range	-65	150	°C
Peak Lead Soldering Temperature (40s, reflow)		260 (+0, -5)	°C

Operating Ratings

Performance is generally guaranteed over this range as further detailed below under Electrical Characteristics.

Parameter	Min	Max	Units
Input Voltage	3.0	5.5	V
Output Voltage	0.6	5.5	V
Output Current (VIN = 3V to 5V)	0	4	A
Ambient Temperature	0	85	°C

Note: Corresponding Max Junction Temperature is 125°C

Microsemi

Electrical Characteristics

Unless otherwise specified, the following specifications apply over the operating ambient temperature of $0^{\circ}\text{C} \leq T_A \leq 85^{\circ}\text{C}$ with the following test conditions: $P_{VIN} = 5\text{V}$. Typical parameters refers to $T_J = 25^{\circ}\text{C}$. $V_{OUT} = 0.9\text{V}$. V_{OUT} is disconnected from FB for open loop tests. $I_{load} = 0$. EN=high, GBD specifications are guaranteed by design and/or characterization and are not tested on a production basis.

Symbol	Parameter	Conditions	Min	Typ	Max	Units
PVIN						
I_{QPSM}	PSM Bias Current	Enable PSM		280		μA
I_{SLEEP}	Input Current at Shutdown	EN = low, $T_J = 25^{\circ}\text{C}$		0.1	3	μA
$UVLO_{RISING}$	Under Voltage Rising Threshold	PVIN rising			2.8	V
$UVLO_{HYST}$	UVLO Hysteresis	PVIN falling		0.2		V
OVP_R	Over Voltage Rising Threshold	PVIN rising. Will also trigger on $DV/DT > 1\text{V}/\mu\text{s}$		6.1		V
OVP_F	Over Voltage Falling Threshold	PVIN falling	5.5	5.85		V
VREF						
V_{REF}	Reference Voltage			0.6		V
T_{SS}	V_{REF} Slew Rate			3.75		$\text{mV}/\mu\text{s}$
T_{HICCUP}	Hiccup Time			1.2		ms
VOUT						
V_{OUT}	V_{OUT} Accuracy	V_{OUT} is set to 0.9V with 0.1% feedback resistors. $P_{VIN} = 5\text{V}$, , 0°C to 85°C .	0.891	0.9	0.909	V
	Line Regulation	V_{IN} from 3V to 5V, $V_{OUT} = 0.9\text{V}$. Note 1		0.01 0.06		%/V
		$I_{LOAD} = 0.1\text{A}$ (in DCM)				
		$I_{LOAD} = 2.5\text{A}$ (in CCM)				
V_{OUTLR}	Load Regulation	$V_{OUT} = 0.9\text{V}$, $I_{OUT} = 0\text{A}$ to 4A . Note 1		-0.06		%/A
FB_{IL}	FB Input Current				1	μA
FB_{UV}	FB Under Voltage Threshold	V_{OUT} below this threshold will initiate a hiccup sequence.		80		% V_{REF}
R_{DISC}	Output Discharge Resistance	EN = low	80	314	500	Ω
SW						
R_{DSON_H}	High Side On Resistance			46		$\text{m}\Omega$

Microsemi®

Symbol	Parameter	Conditions	Min	Typ	Max	Units
$R_{\text{DS(on)_L}}$	Low Side On Resistance			21		mΩ
I_{RATED}	Rated Output Current	PVIN = 3V to 5V. Note 1	4			A
I_{CL}	Current Limit	Peak inductor current. PVIN = 3V to 5V . Note 1	6.3	7.4	9	A
T_{SH}	Thermal Shutdown Threshold ¹	Note 1		150		°C
T_{H}	Thermal Shutdown Hysteresis ¹	Note 1		20		°C
F_{SW}	PWM Switching Frequency	$V_{\text{OUT}} / V_{\text{IN}} \geq 35\%$, T=25°C, Note 1	1.55	1.65	1.75	MHz
EN						
V_{IH}	Input High				1.2	V
V_{IL}	Input Low		0.4			V
I_{IN}	Input Current			0.01	1	μA
PG						
V_{PG90}	PGOOD V_{OUT} Lower Threshold	V_{OUT} rising, percentage of V_{REF}		90		%
V_{PG110}	PGOOD V_{OUT} Upper Threshold	V_{OUT} falling, percentage of V_{REF}		110		%
V_{PGHY}	Hysteresis	Percentage of V_{REF}		5		%
PG_{RDSON}	PGOOD Pull-down Resistance			13	50	Ω
PG_{LEAK}	PGOOD Leakage Current	$T_{\text{J}} = 25^{\circ}\text{C}$		0	1	μA

Note 1: These parameters are not tested, but guaranteed by design and characterization.



Microsemi

Typical Performance Curves (Efficiency)

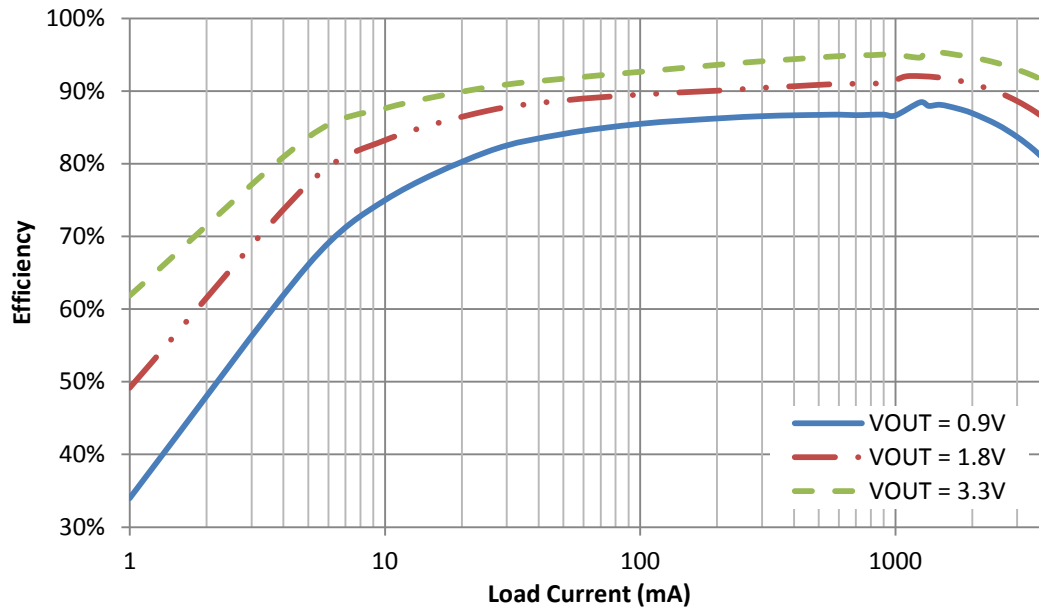

Figure 4: LX7176A Efficiency with $V_{IN} = 5V$, $L = 0.47\mu H$, $C_{OUT} = 22\mu F$



Microsemi

Step Response (Load Current = 1.5A to 4A, $L = 0.47\mu\text{H}$, $C_{\text{OUT}} = 22\mu\text{F}$) Typical Performance Curves

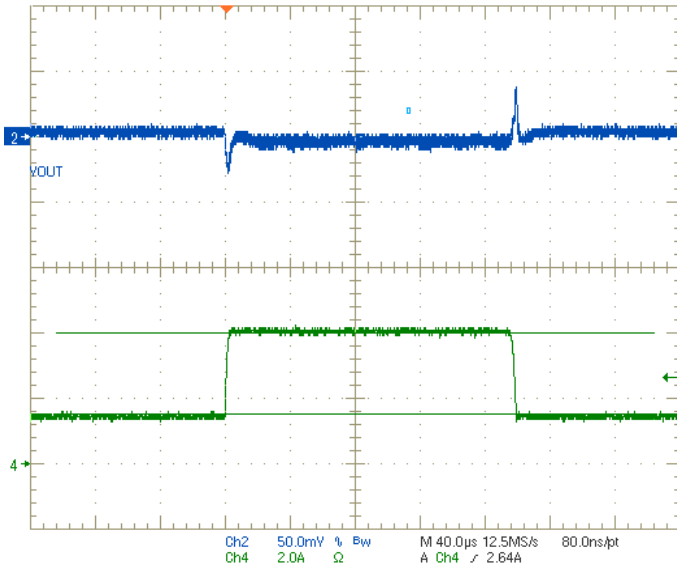

Figure 5. Step Load

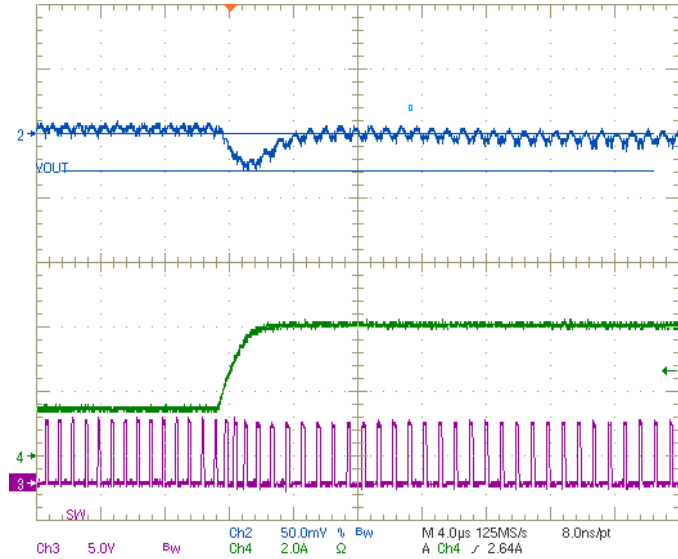

Figure 6. Step Load Rising Edge

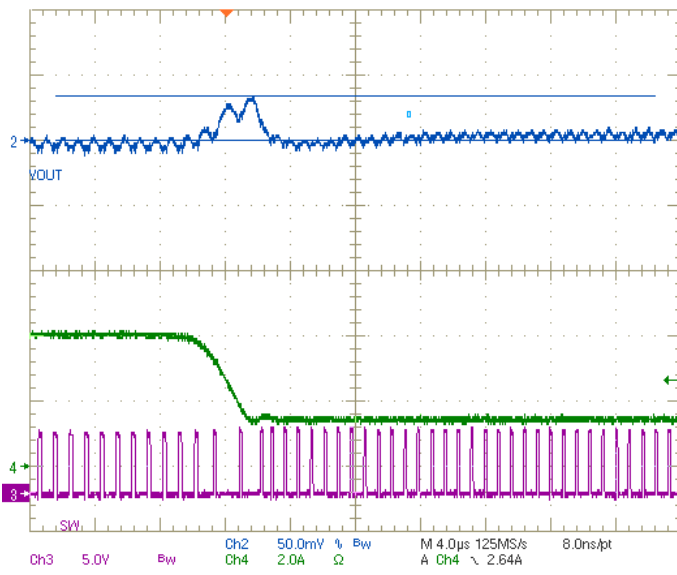

Figure 7. Step Load Falling Edge

Microsemi®

Theory of Operation

Basic Operation

The LX7176A compares the FB voltage to an internal reference, V_{REF} . When FB is lower than V_{REF} , the upper switch turns on and the lower switch turns off. When FB is higher than V_{REF} , the upper switch turns off and the lower switch turns on. An internal ramp and a frequency control loop keep the switching frequency constant when in constant conduction mode (CCM) over a wide range of output capacitor values and parasitic components (i.e. ESR, ESL).

At light loads, the converter automatically reduces the switching frequency to optimize conversion efficiency.

Startup

The LX7176A is enabled when EN is high and PVIN rises above the UVLO threshold. At start up, after all the internal bias voltages and currents stabilize, V_{REF} ramps up from 0V to the target voltage at the defined slew rate. While V_{REF} ramps, PGOOD is held low. At the end of the ramp time, PGOOD is allowed to go high if the FB has reached the PGOOD rising threshold.

Over Current Protection

The LX7176A protects against all types of short circuit conditions. Cycle by cycle over current protection turns off the upper switch when the current exceeds the I_{CL} threshold. When this occurs, the upper switch is kept off for about 360ns before being allowed to turn on again. After startup, if FB drops below the FB_{UV} threshold,

a hiccup sequence will be initiated where both output switches are shut off for 1.2ms before initiating another soft start. This protects against a crowbar short circuit. FB under voltage detection is not active during startup.

Setting the Output Voltage

The reference voltage is 0.6V

$$V_{OUT} = \left(\frac{R_1}{R_2} + 1 \right) \cdot V_{REF} \quad (1)$$

Where R_1 is high side feedback divider resistor, R_2 is low side feedback divider resistor, V_{REF} is 0.6V.



Microsemi

Recommended Output Filter Components

The following tables show recommended feedback component values (R_{HIGH} , R_{LOW} , C_{ff}) for different input/output voltages, power inductor (L), and output capacitance (C) values that result in optimum closed loop response of the regulator in each case. The estimated crossover frequency is also shown in the table in each case. If the L*C factor exceeds a certain number the regulator would run with low phase margin, or become unstable. The L and C range provided in the table provides 30°, or higher of phase margin. Therefore, it is not recommended to increase L*C factor beyond what is given in the table.

It is a good practice to determine L such that the peak-to-peak inductor ripple current in continuous conduction mode operation is roughly equal to 30% of converter's rated output current. In general, increasing the inductance slows down the closed loop response of the regulator. Hence, for applications that require fast line/load transient response, lower inductance values should be preferred over larger ones. Output capacitance can be determined based on desired output ripple voltage staying within the limits provided in the table depending on the inductance value.

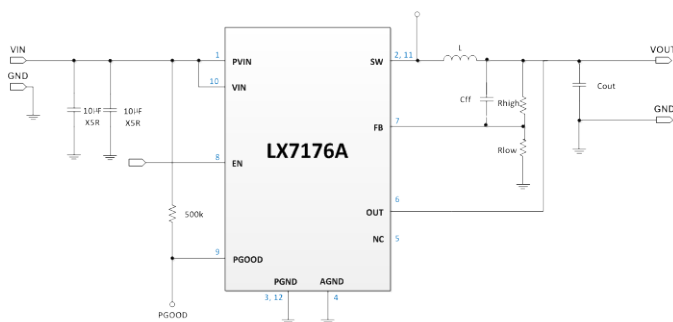

V_{IN} (V)	V_{OUT} (V)	L (μ H)	C_{OUT} (μ F)	R_{HIGH} (k Ω)	R_{LOW} (k Ω)	C_{ff} (pF)	F crossover (kHz)	
5.0	0.9	2.2	4x22	60	120	47	70	
			3x22				83	
			2x22				33	100
			1x22				12	150
		1.5	5x22			27	73	
			4x22				84	
			3x22				100	
			2x22				12	120
			1x22				200	
		1.0	5x22			22	92	
			4x22				110	
			3x22				130	
			2x22				12	170
			1x22				300	
		0.47	5x22			10	140	
			4x22				170	
			3x22				220	
			2x22				0	280
			1x22				575	
		0.33	5x22			6.8	180	
4x22	220							
3x22	280							
2x22	0		400					
1x22	7.5		15	625				



Microsemi

Recommended Output Filter Components - Continued

V _{IN} (V)	V _{OUT} (V)	L (μH)	C _{OUT} (μF)	R _{HIGH} (kΩ)	R _{LOW} (kΩ)	C _{ff} (pF)	F crossover (kHz)
3.0	0.9	2.2	2x22	60	120	33	76
			1x22			12	110
		1.5	3x22			27	74
			2x22			12	90
			1x22				140
		1.0	5x22			22	68
			4x22				78
			3x22				93
			2x22			12	120
			1x22				190
		0.47	5x22			10	100
			4x22				120
			3x22				150
			2x22			0	180
			1x22				325
		0.33	5x22			6.8	130
			4x22				150
			3x22				190
			2x22			0	240
			1x22				475

V _{IN} (V)	V _{OUT} (V)	L (μH)	C _{OUT} (μF)	R _{HIGH} (kΩ)	R _{LOW} (kΩ)	C _{ff} (pF)	F crossover (kHz)	
5.0	1.8	2.2	5x22	240	120	12	49	
			4x22				57	
			2x22				6.8	70
			3x22					85
			1x22					150
			1.5				5x22	6.8
		4x22				68		
		3x22				84		
		2x22				120		
		1x22				200		
		1.0	5x22			6.8	77	
			4x22				92	
			3x22				120	
			2x22			0	130	
			1x22				260	
		0.47	5x22			0	110	
			4x22				130	
			3x22				180	
			2x22				190	
			1x22				475	
0.33	5x22	0	150					
	4x22		190					
	3x22		260					
	2x22		220					
	1x22		500					



Microsemi

Recommended Output Filter Components - Continued

V _{IN} (V)	V _{OUT} (V)	L (μH)	C _{OUT} (μF)	R _{HIGH} (kΩ)	R _{LOW} (kΩ)	C _{ff} (pF)	F crossover (kHz)
3.0	1.8V	2.2	5x22	240	120	12	36
			4x22				42
			3x22				50
			2x22				60
			1x22				100
			1.5				5x22
		4x22				49	
		3x22				60	
		2x22				79	
		1x22				140	
		1.0				5x22	55
			4x22			64	
			3x22			79	
			2x22			87	
			1x22			150	
			0.47			5x22	76
		4x22				89	
		3x22				110	
		2x22				160	
		1x22				350	
		0.33				5x22	97
			4x22			120	
			3x22			150	
			2x22			240	
1x22	525						

V _{IN} (V)	V _{OUT} (V)	L (μH)	C _{OUT} (μF)	R _{HIGH} (kΩ)	R _{LOW} (kΩ)	C _{ff} (pF)	F crossover (kHz)
5.0	3.3	2.2	5x22	540	120	22	58
			4x22				67
			2x22				81
			3x22				110
			1x22				170
			1.5				5x22
		4x22				87	
		3x22				100	
		2x22				140	
		1x22				240	
		1.0				5x22	100
			4x22			120	
			3x22			140	
			2x22			190	
			1x22			325	
			0.47			5x22	170
		4x22				200	
		3x22				240	
		2x22				350	
		1x22				450	
		0.33				5x22	220
			4x22			260	
			3x22			325	
			2x22			475	
1x22	525						



Package Dimensions

QFN 2x2mm 12L Package

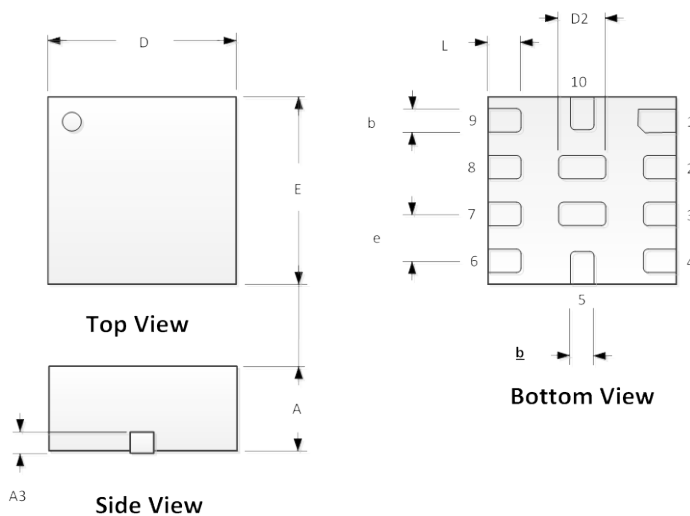

Dim	MILLIMETERS		INCHES	
	MIN	MAX	MIN	MAX
A	0.80	1.00	0.031	0.039
A3	0.20 REF		0.008 REF	
B	0.20	0.30	0.008	0.012
D	1.90	2.10	0.075	0.083
D2	0.50BSC		0.02BSC	
E	1.90	2.10	0.075	0.083
e	0.50 BSC		0.020 REF	
L	0.30	0.45	0.012	0.018

Note:

1. Dimensions do not include mold flash or protrusions; these shall not exceed 0.155mm (.006") on any side. Lead dimension shall not include solder coverage.
2. Dimensions are in millimeters, inches for reference only.

Recommended Footprint

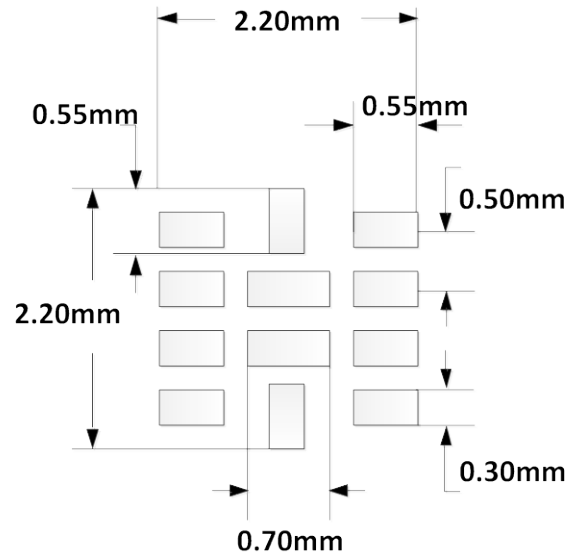
Microsemi®

Disclaimer:

This PCB land pattern recommendation is based on information available to Microsemi by its suppliers. The actual land pattern to be used could be different depending on the materials and processes used in the PCB assembly, end user must account for this in their final layout. Microsemi makes no warranty or representation of performance based on this recommended land pattern.

PRODUCTION DATA – Information contained in this document is pre-production data and is proprietary to Microsemi. It may not be modified in any way without the express written consent of Microsemi. Product referred to herein is offered in pre-production form only and may not have completed Microsemi's Quality Assurance process for Release to Production. Microsemi reserves the right to change or discontinue this proposed product at any time.

X-ON Electronics

Largest Supplier of Electrical and Electronic Components

Click to view similar products for [Voltage Regulators - Switching Regulators](#) category:

Click to view products by [Microsemi](#) manufacturer:

Other Similar products are found below :

[LX7186A](#) [622616F](#) [632259F](#) [FAN53610AUC33X](#) [MP2148GQD-33-P](#) [MP2374DS-LF-Z](#) [EN6310QA](#) [NCP81108MNTXG](#)
[NCP81109BMNTXG](#) [L79M05TL-E](#) [FAN48610BUC45X](#) [R3](#) [LV5710GP-TE-L-H](#) [430464BB](#) [455605G](#) [AZ7500BMTR-E1](#) [MIC23156-](#)
[0YML-T5](#) [MIC4930YFL-T5](#) [MP8763GLE-P](#) [KE177614](#) [418569H](#) [455596X](#) [511087D](#) [030908C](#) [063375FB](#) [067501FB](#) [099508GB](#)
[EP5358LUA](#) [NCP81102MNTXG](#) [715715H](#) [FAN48611UC53X](#) [FAN53611AUC12X](#) [MAX809TTR](#) [MAX77596ETBC+T](#)
[MAX77596ETBB+T](#) [MAX16905AUE/V+](#) [NCP6332CMTAATBG](#) [NCV890203MWTXG](#) [LX7176A](#) [ISL8018IRAJZ](#) [MP2162AGQH-Z](#)
[MAX17544ATP+T](#) [EN6360QI](#) [MCP1623T-IMC](#) [MCP1642B-18IMC](#) [MCP1642BT-30I/MS](#) [MCP1642D-50IMC](#) [MCP1642D-50IMS](#)
[MCP1642D-ADJIMC](#) [MC34063LBBGEVB](#)