

3V to 5.5V, 5A Constant Frequency Hysteretic Synchronous Buck Regulator with I²C Production Datasheet



Microsemi

Description

The LX7178 is a digitally controlled step-down regulator IC with an integrated 40mΩ high-side P-channel MOSFET and a 14mΩ low-side N-channel MOSFET. It features Microsemi’s proprietary constant-frequency hysteretic control engine for near-instantaneous correction to line/load transients. It does not require high-ESR output capacitors and incorporates energy-saving “PSM” (Power Save or Pulse Skip Mode) at light loads, to extend battery life in mobile applications.

The LX7178 has an I²C serial interface port for output voltage margining and monitoring if required (it can also operate in default mode). In addition it includes robust fault monitoring functions.

The LX7178 will operate from 3V to 5.5V, and is available in 0.8V fixed output voltage option (no voltage divider is necessary). The output voltage can also be adjusted with an external voltage divider up to 3.3V.

Features

- ◆ Constant Frequency Hysteretic Control
- ◆ Extremely Fast Line/Load Transient Response
- ◆ I²C for Output Adjustment (3.4Mbps)
- ◆ 1.875 MHz Switching Frequency
- ◆ Extremely Low-R_{DS(on)} MOSFETS
- ◆ Input Voltage Rail 3.3V to 5V
- ◆ Greater than 5A Output Current
- ◆ I²C Selectable Power Save Mode for Light-Load Efficiency
- ◆ UVLO, OVP, OCP
- ◆ 0°C to +85°C Ambient Temperature
- ◆ Available in WLCSP-20 (0.4mm pitch)
- ◆ RoHS Compliant

Applications

- High Performance HDD
- Notebooks/Netbooks/Tablets/Slates

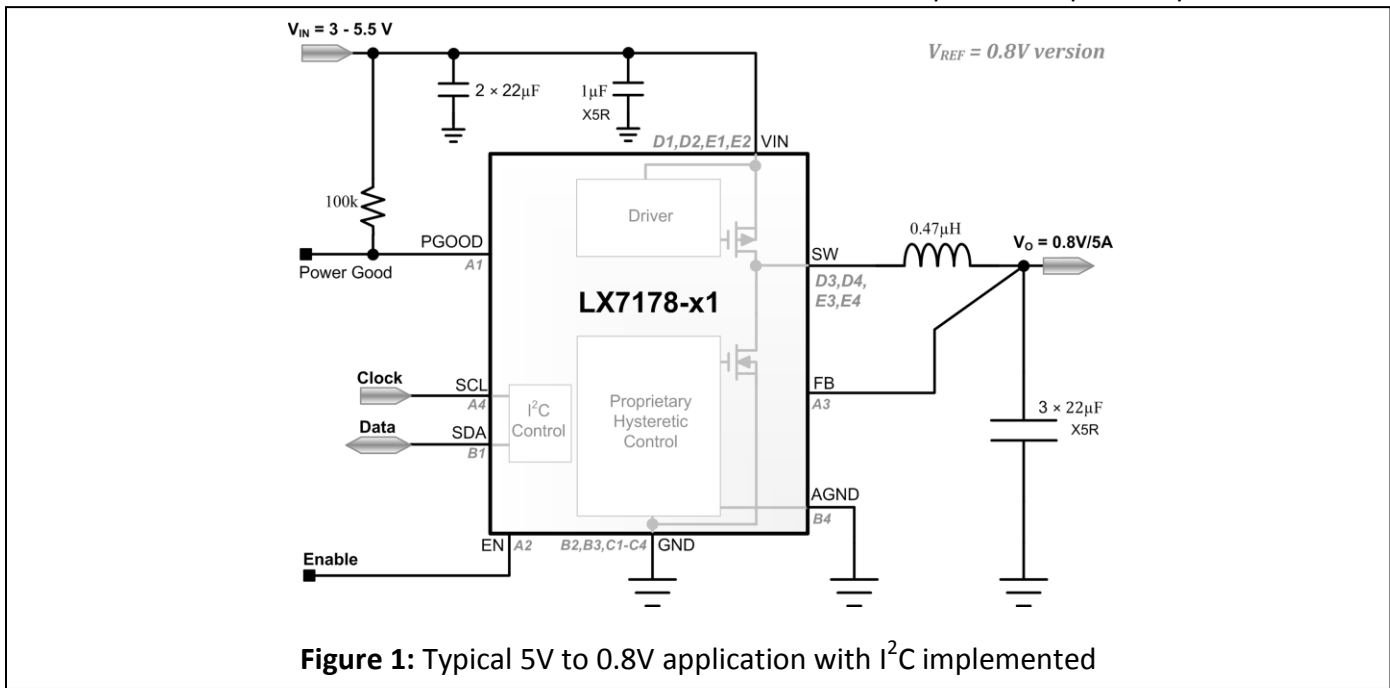



Microsemi

Other Application Diagrams

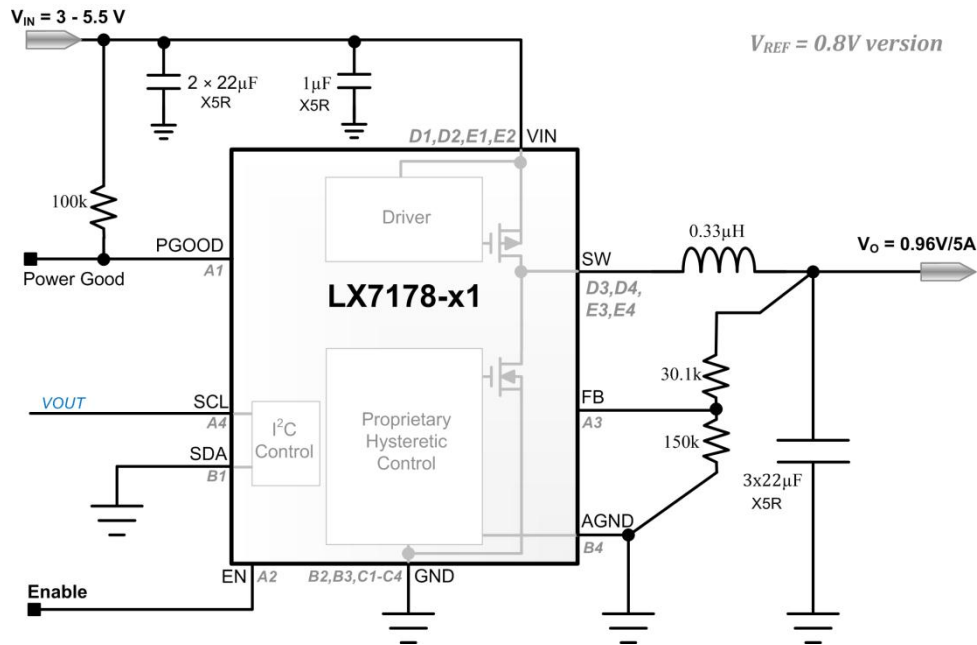

Figure 2: Typical 5V to 0.96V application without I²C implemented

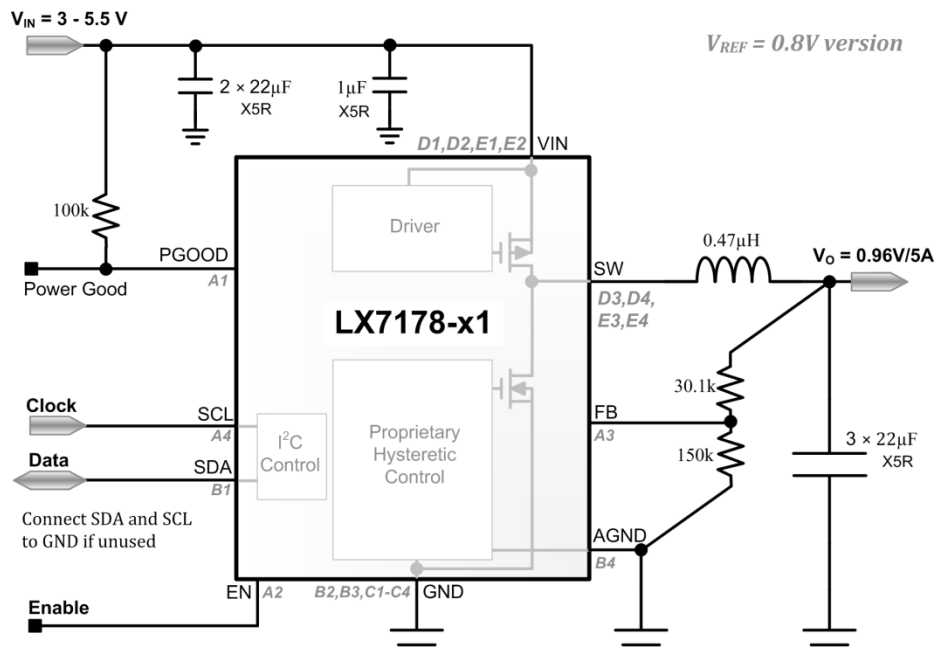
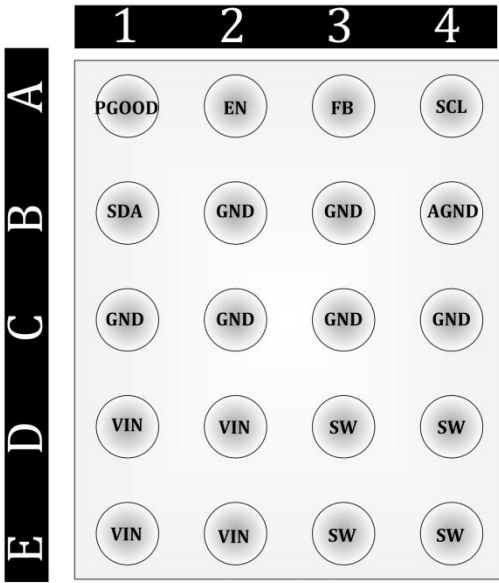

Figure 3: Typical 5V to 0.96V application with I²C implemented



Microsemi

Pin/Ball Configuration



LX7178

Top View
(Ball Side Down)
20-ball Wafer Scale Package

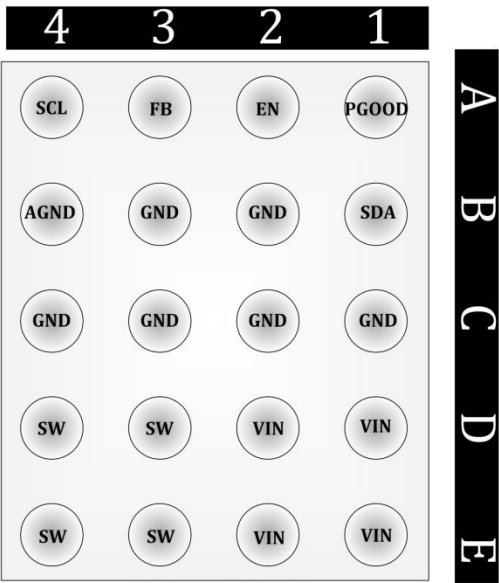

LX7178

Bottom View
(Ball Side Up)
20-ball Wafer Scale Package

Part Marking:

MSC	XXXX=Device Number	YWWA
XXXX	E.g.: 7801=LX7178-01CSP	Year/Work Week/Lot Code
YWWA		

Figure 4: Pinout

Ordering Information

Ambient Temperature	Type	Package	Set Output Voltage	Part Number	Packaging Type
0°C to 85°C	RoHS compliant, Pb-free	WLCSP-20 (0.4mm pitch)	0.8V	LX7178-01CSP LX7178-xyCSP*	Bulk
			0.8V	LX7178-01CSP-TR LX7178-xyCSP-TR*	Tape and Reel

* Consult factory for other I²C slave address and set output voltage options.
 "x" is the 2 LSB bits of the binary I²C slave address (0 to 3);
 "y" is the set output voltage (0 is 0.6V, 1 is 0.8V, 2 is 0.9V, 3 is 0.975V)

3V to 5.5V, 5A Constant Frequency Hysteretic Synchronous Buck Regulator with I²C Production Datasheet



Microsemi

Pin/Ball Description

Pin/Ball Number	Pin/Ball Designator	Description
A1	PGOOD	Open Drain status output, requires external pull up resistor. This pin will go low when VOUT is outside the defined power good range, when the die is hotter than the thermal shutdown threshold, when PVIN is above the over voltage threshold, or when PVIN is below the under voltage threshold.
A2	EN	Enable for switching regulator. Force high to enable, force low to disable the IC.
A3	FB	Feedback Voltage sense – Analog Input – This voltage is compared with the internal V _{REF} voltage to control the hysteretic converter. Normally this is connected to VOUT via a resistor divider network.
A4	SCL	Serial Data Clock – Logic Input – Clock for the serial interface. Glitches shorter than 50nS will be ignored. If the serial interface is not used, connect to GND or VIN. This pin can also be connect to VOUT if required by the layout.
B1	SDA	Serial Data – Bi-Directional Logic – This I ² C pin is used to receive clocked serial data from the host and to send clocked serial data to the host. Glitches shorter than 50nS will be ignored. If the serial interface is not used in the application, this pin should be connected to VIN or GND.
B2, B3, C1 – C4	GND	Ground. Connect to ground plane.
B4	AGND	Analog Ground. Connect to ground plane.
D1, D2 E1, E2	VIN	Input of IC and buck stage. Connect to input rail VIN (between 3V and 5.5V). A minimum input capacitance of one 1μF and one 22μF of X5R or better multilayer ceramic, should be placed very close to IC between this node and GND.
D3, D4 E3, E4	SW	Switching Node. Drives the external L-C low pass filter.



Microsemi

Functional Block Diagram

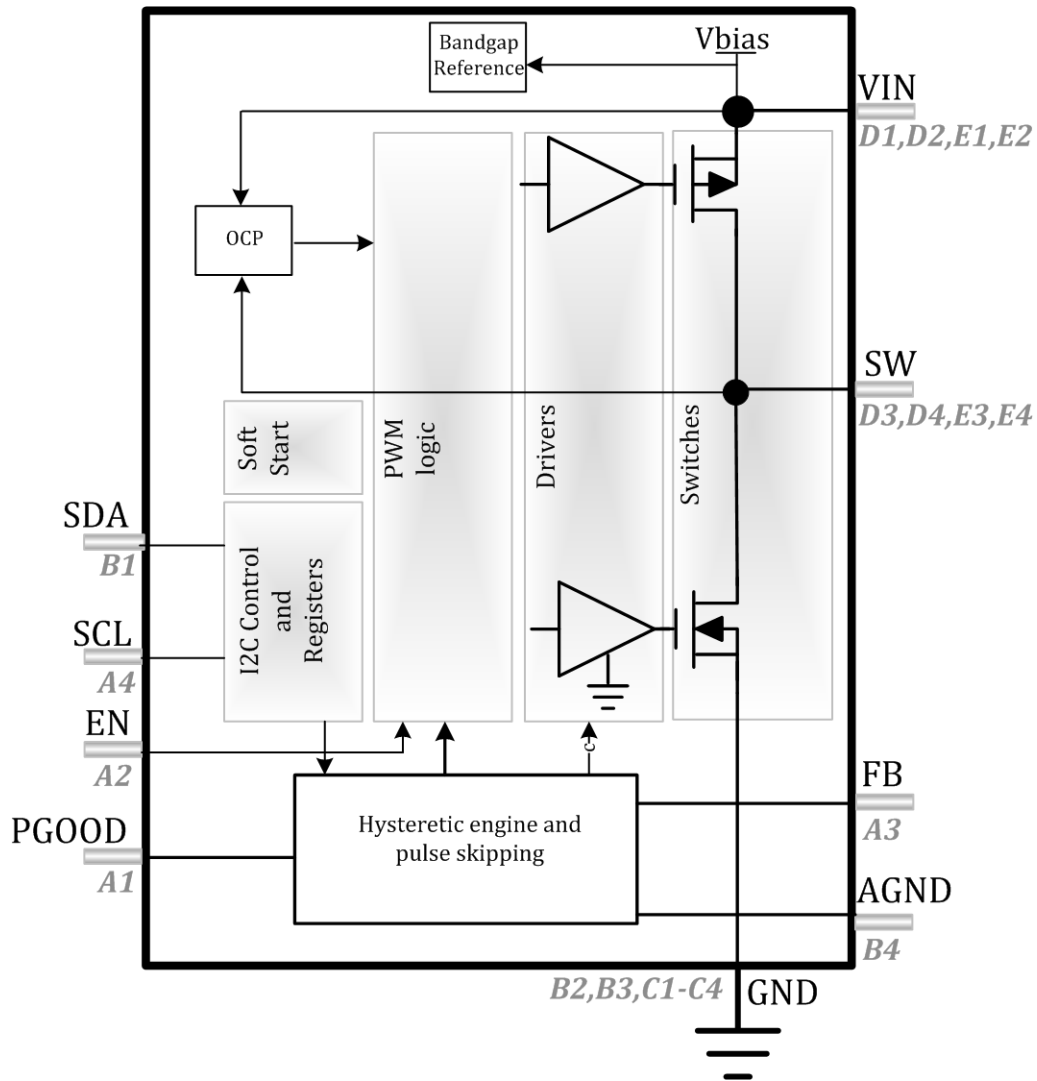

Figure 5: Block Diagram

**3V to 5.5V, 5A Constant Frequency Hysteretic
Synchronous Buck Regulator with I²C
Production Datasheet****Microsemi****Absolute Maximum Ratings**

Performance is not necessarily guaranteed over this entire range. These are maximum stress ratings only. Exceeding these ratings, even momentarily, can cause immediate damage, or negatively impact long-term operating reliability.

	Min	Max	Units
VIN, SW to GND	-0.3	7	V
EN, FB, SDA, SCL, PGOOD to GND	-0.3	7	V
SW to GND (Shorter than 50ns)	-2	7	V
Maximum Junction Temperature		150	°C
Lead Soldering Temperature (40s, reflow)		260 (+0, -5)	°C
Storage Temperature	-65	150	°C

Operating Ratings

Performance is generally guaranteed over this range as further detailed below under Electrical Characteristics.

	Min	Max	Units
VIN	3	5.5	V
Ambient Temperature	0	85	°C
Output Current		5	A

Note: Corresponding Absolute Max Junction Temperature is 150°C.

Thermal Properties

Thermal Resistance	Typical	Units
θ_{JA}	38	°C/W

Note: The θ_{JA} number assume no forced airflow. Junction Temperature is calculated using $T_j = T_A + (P_D \times \theta_{JA})$. In particular, θ_{JA} is a function of the PCB construction. The stated number above is for a four-layer board in accordance with JESD-51 (JEDEC).



Microsemi

Electrical Characteristics

Unless otherwise specified under conditions, the Min and Max ratings stated below apply over the entire specified operating ratings of the device. Typ values stated, are either by design or by production testing at 25°C ambient.

Symbol	Parameter	Conditions	Min	Typ	Max	Units
Input Voltage						
I _Q	Input current	I _{LOAD} = 0, PSM enabled	200	440	600	μA
I _{IN}	Input current at shut down	EN = GND, T _A = 25°C		0.1	3	μA
I _{IN_I²C}	Input current I ² C shut down	VSEL(7) = low, EN = high		100	120	μA
UVLO	Under voltage rising threshold	VIN rising		2.6	2.8	V
UVLO _{HYST}	UVLO hysteresis			0.26		V
OVP _R	Over voltage rising threshold	VIN_OVP: Ctrl1(1) = 1	6.25		6.75	V
OVP _F	Over voltage falling threshold	VIN_OVP: Ctrl1(1) = 1	5.75		6.2	V
Reference Voltage						
V _{REFMIN}	Minimum reference voltage	VSEL(6:0) = 00h	0.588	0.6	0.612	V
V _{REFMEAN}	Mean reference voltage	VSEL(6:0) = 40h	0.888	0.9	0.912	V
V _{REFMAX}	Maximum reference voltage	VSEL(6:0) = 7Fh	1.184	1.195	1.206	V
T _{SS}	V _{REF} slew rate	SLEW: Ctrl2(2:0) = 011	3	4	5.5	mV/μs
T _{HICCUP}	Hiccup time	VOUT = 0.2V		1.5		ms
Output Voltage						
V _{OUT}	Default VOUT	Target based on option: 01 = 0.8. Measured with respect to target voltage.	-1.5	0	1.5	%
	Line regulation	VIN from 3V to 5.5V, I _{LOAD} = 1A. Note 1		0.1		%
	Load regulation	I _{LOAD} = 0A to 5A. Note 1		-0.17		%/A
	VOUT input current			0	1	μA
V _{Ouv}	VOUT under voltage threshold	VOUT below this threshold will initiate a hiccup sequence	77	82	85	%V _{REF}

3V to 5.5V, 5A Constant Frequency Hysteretic Synchronous Buck Regulator with I²C

Production Datasheet



Microsemi

Symbol	Parameter	Conditions	Min	Typ	Max	Units
SW						
R _{DSON_H}	High side on resistance			40		mΩ
R _{DSON_L}	Low side on resistance			14		mΩ
OCP	Current limit	Note 1	6.5	7.5	9	A
T _{SH}	Thermal shut down threshold	Note 1		150		°C
T _H	Hysteresis	Note 1		20		°C
F _{SW}	PWM switching frequency		1.5	1.875	2.25	MHz
R _{SWDISC}	SW discharge resistance	EN = low; Discharge: Ctrl2(4) = 1;	80	200	1400	Ω
EN, SDA (as input), SCL						
V _{IH}	Input high		1.1			V
V _{IL}	Input low				0.4	V
V _H	Hysteresis			0.1		V
I _{II}	Input current			0.01	1	μA
PGOOD						
V _{PG90}	PGOOD VOUT lower threshold	VOUT rising, percentage of V _{REF}	85	90	95	%V _{REF}
V _{PG110}	PGOOD VOUT upper threshold	VOUT falling, percentage of V _{REF}	105	110	115	%V _{REF}
V _{PGHY}	Hysteresis	Percentage of V _{REF}		5		%V _{REF}
P _{G_RDSON}	PGOOD pull down resistance			100	300	Ω
	PGOOD leakage current			0	1	μA
	PGOOD delay	PGOOD rising edge delay (only when enabled by setting CTRL 1:5 to 0). By default, this delay is not enabled.	30	45	65	ms
7 Bit DAC						
	Differential linearity	Monotonicity assured by design			0.8	LSB

Note 1: Guaranteed by design.

**3V to 5.5V, 5A Constant Frequency Hysteretic
Synchronous Buck Regulator with I²C
Production Datasheet**



Microsemi

Application Specifics

Efficiency	$I_{OUT} = 1.5A, VCC = 5V, VOUT = 3.3V$	95%
	$I_{OUT} = 5.0A, VCC = 5V, VOUT = 3.3V$	90%
VOUT Min Transient	0.5 A to 2.5 A load step slews in 900ns, $C_{LOAD} = 3 \times 22\mu F$ ceramic caps, 0.47 μH inductor	31.6mV
VOUT Max transient	2.5 A to 0.5 A load step slews in 1.46 μs , $C_{LOAD} = 3 \times 22\mu F$ ceramic caps, L = 0.47 μH inductor	34.8mV
Typical Load Inductance	DCR = 6.7m Ω , IDC = 12.2A, ISAT = 16A.	0.47 μH
Typical Load Capacitance	6.3V, X5R	3x22 μF



Microsemi

Layout Recommendations

The LX7178 EVAL Board is a 4-layer board, the thickness of the board is 63mil in total. The second layer to top layer is 7mil, the third layer to the bottom layer is 7mil. The recommended BGA PCB layout shown below requires no microvias or blind vias. Each signal trace can exit the LX7178 directly without any vias under the device. Also, with the bypass capacitors C2, C3 and C8 implemented as shown it can lower the ESL. Please see LX7178 User Guide for additional details.

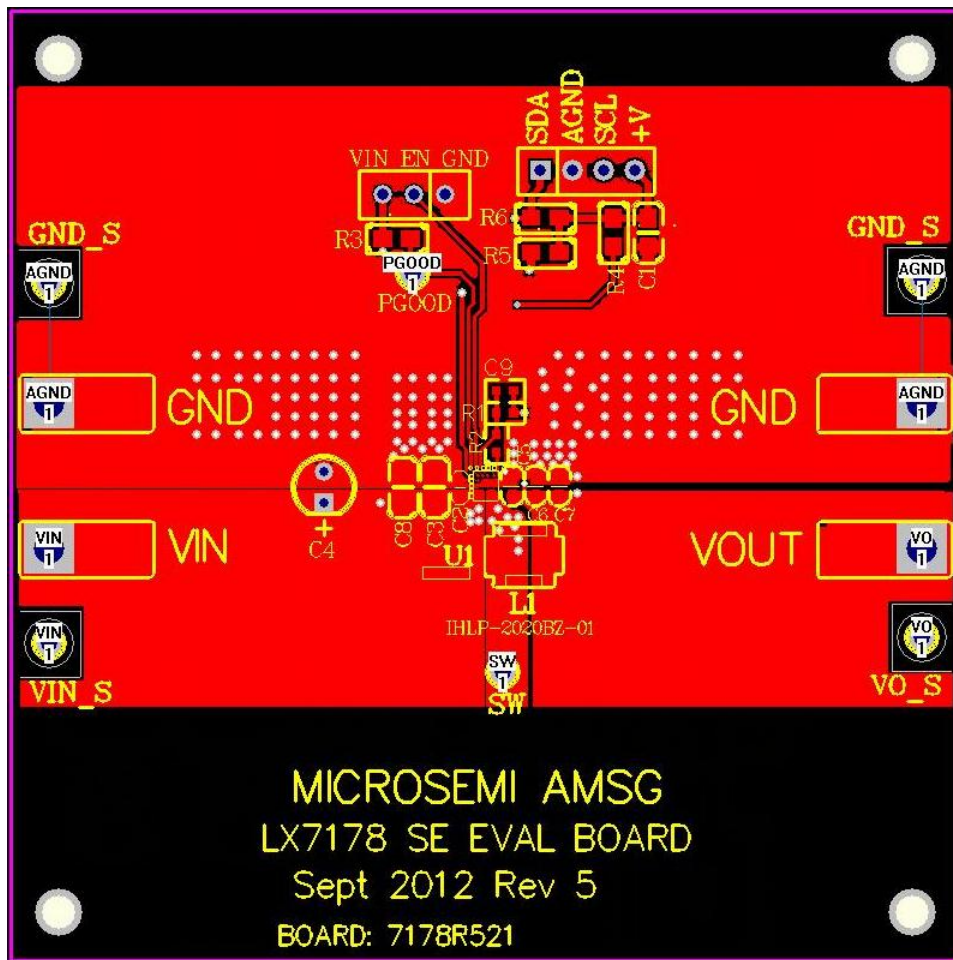

Figure 6: Layout recommendation (TOP layer)



Microsemi

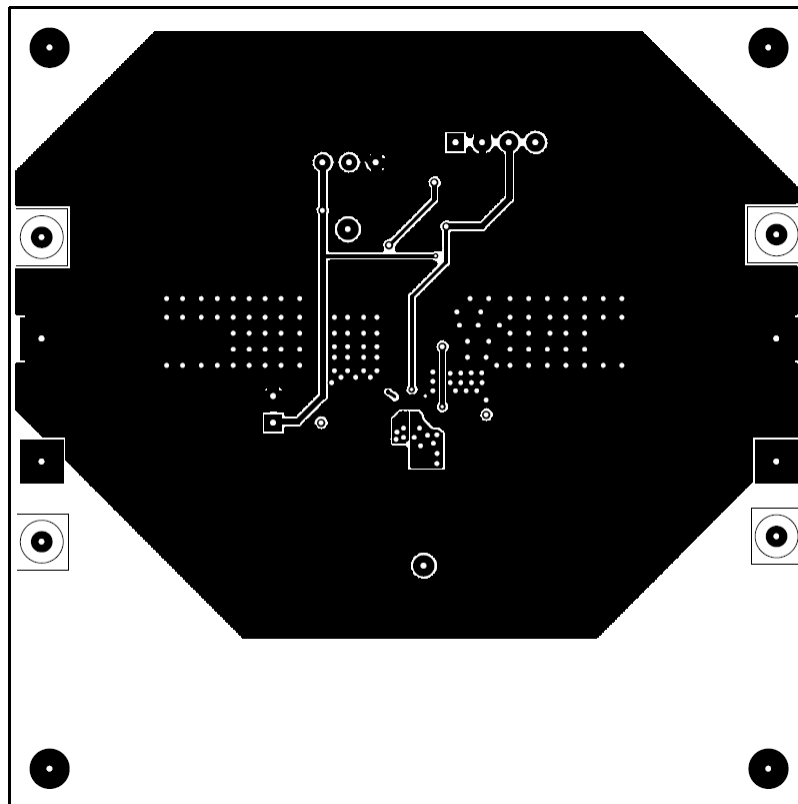

Figure 7: Layout recommendation (BOTTOM layer)

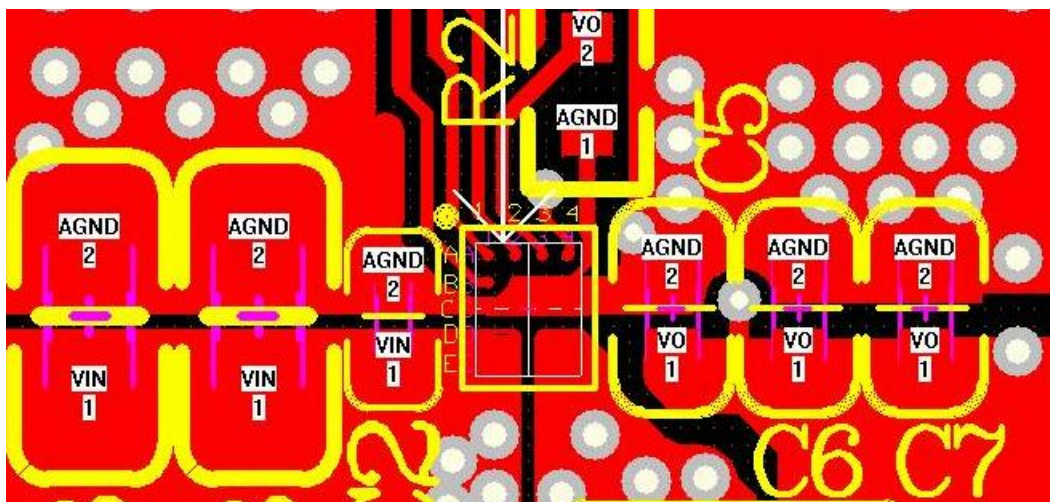

Figure 8: Closeup of Layout in Region of BGA (note Ground gull-wings and via Stitching to BOTTOM)



Microsemi

Typical Performance Curves

Dynamic Response

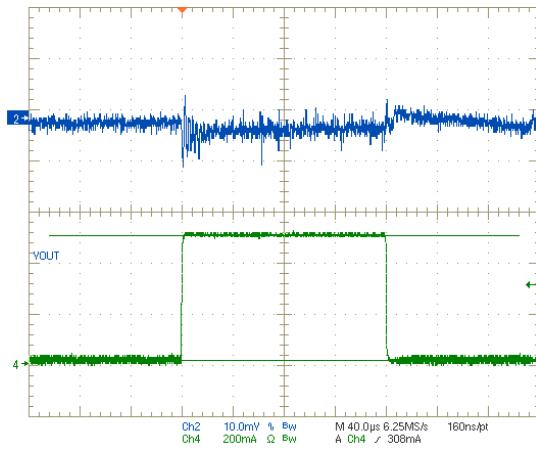

Figure 9: No load to 0.5A PWM
CH2: VOUT, CH4: I_{LOAD}

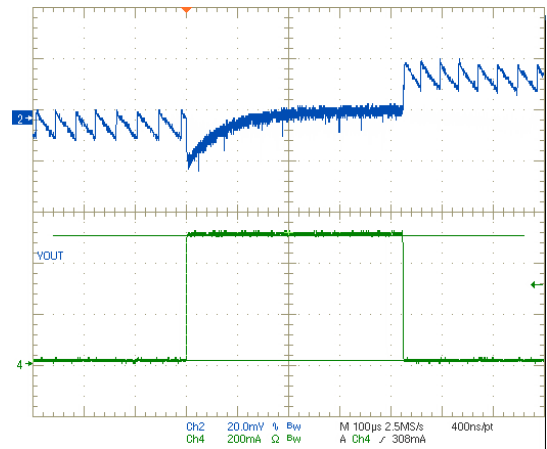

Figure 10: No load to 0.5A PSM
CH2: VOUT, CH4: I_{LOAD}

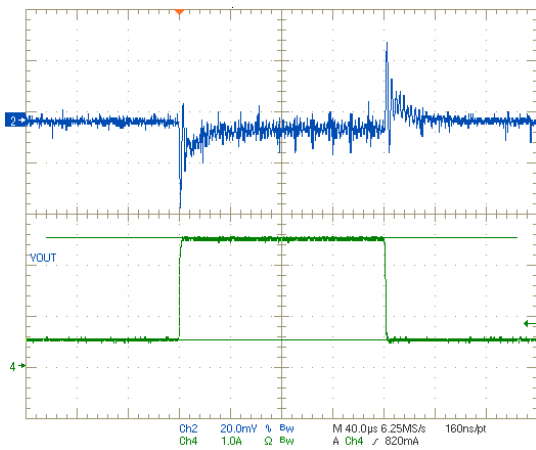

Figure 11: 0.5A to 2.5A PWM
CH2: VOUT, CH4: I_{LOAD}

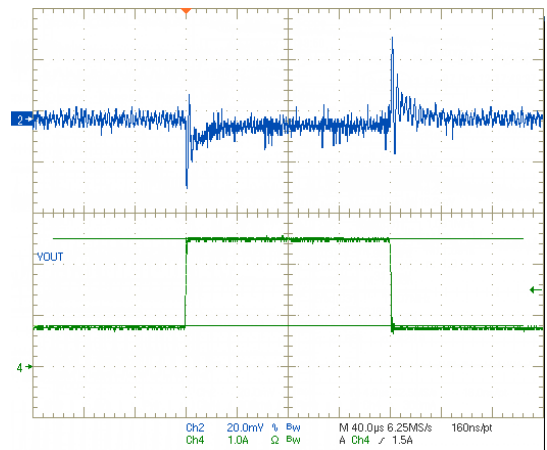

Figure 12: 0.8A to 2.5A PWM
CH2: VOUT, CH4: I_{LOAD}



Microsemi

Typical Performance Curves (Continued)

Dynamic Response (Continued)

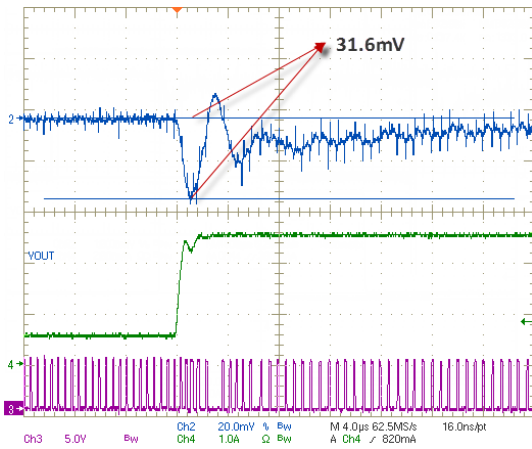

Figure 13: 0.5A to 2.5A PWM Rising Edge
CH2: V_{OUT}, CH3: SW, CH4: I_{LOAD}

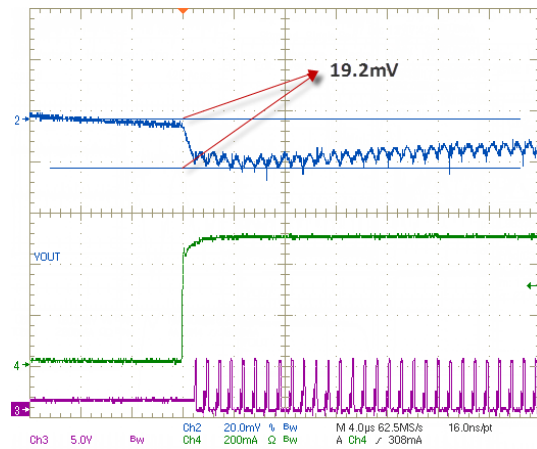

Figure 14: No load to 0.5A PSM Rising Edge
CH2: V_{OUT}, CH3: SW, CH4: I_{LOAD}

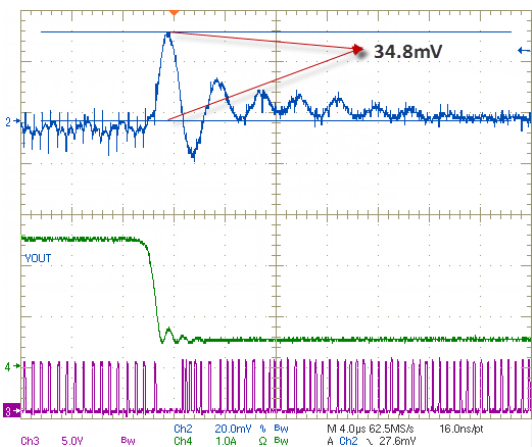

Figure 15: 0.5A to 2.5A PWM Falling Edge
CH2: V_{OUT}, CH3: SW, CH4: I_{LOAD}

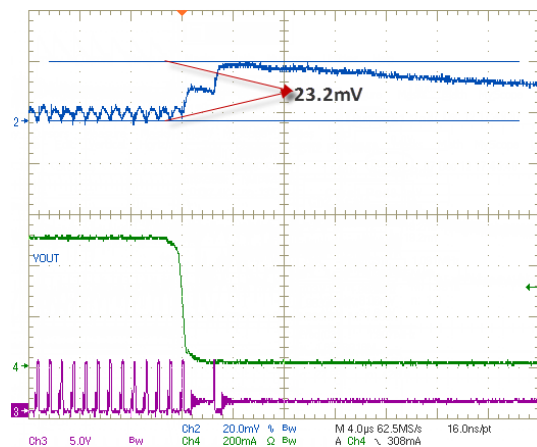

Figure 16: No load to 0.5A PSM Falling Edge
CH2: V_{OUT}, CH3: SW, CH4: I_{LOAD}



Microsemi

Typical Performance Curves (Continued)

Efficiency

LX7178 5V VIN Efficiency

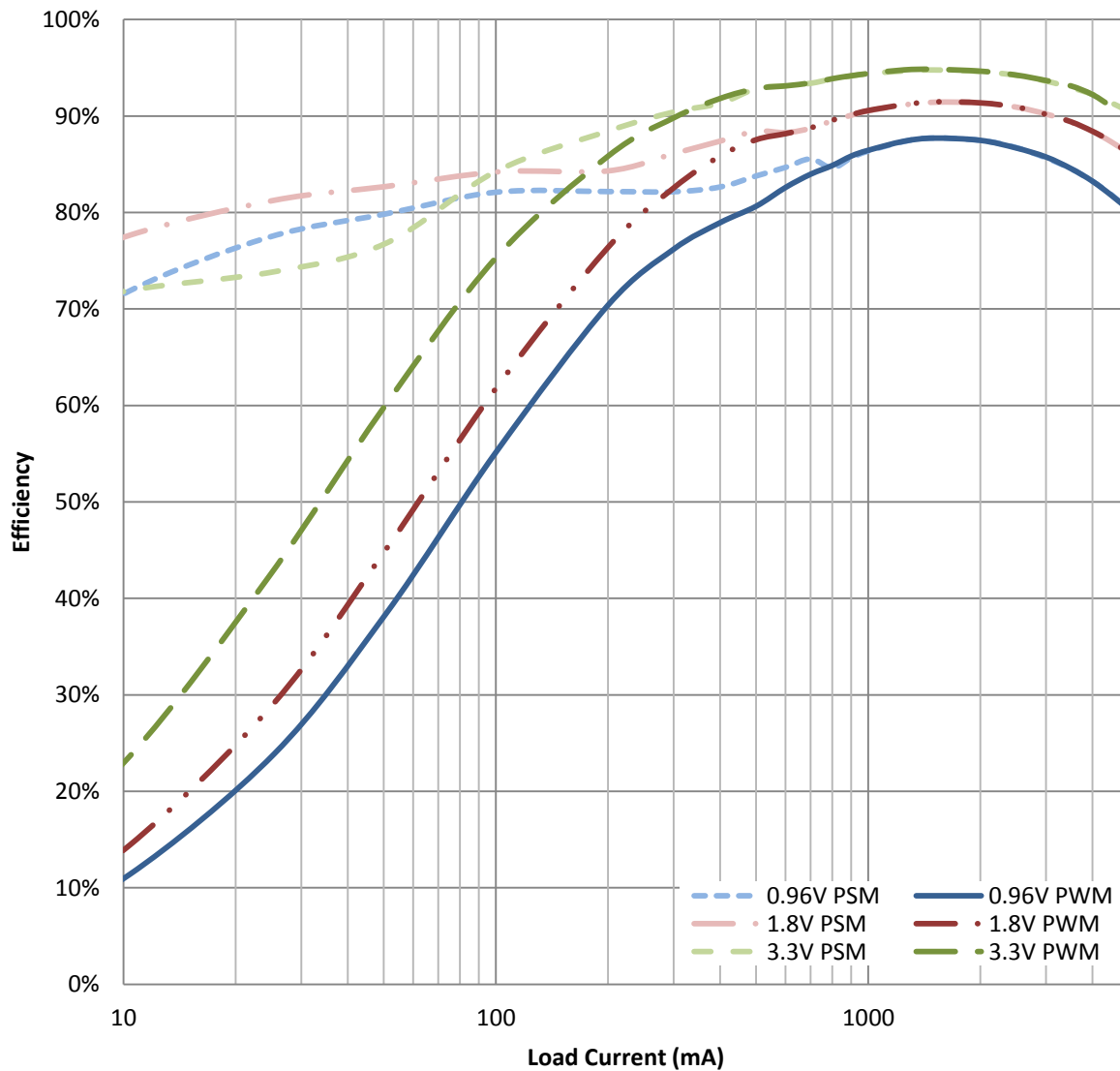

Figure 17: Efficiency Curves for 5V input



Microsemi

I²C Timing Specifications

Symbol	Parameter	Conditions	C _b = 100 pF (max) (*Note2)		C _b = 400 pF		Unit
			Min	Max	Min	Max	
f _{SCHL}	SCL clock frequency		0	3.4	0	0.4	MHz
t _{SU;STA}	Set-up time for a repeated START condition		160	-	600	-	ns
t _{HD;STA}	Hold time (repeated) START condition		160	-	600	-	ns
t _{LOW}	LOW period of the SCL clock		160	-	1300	-	ns
t _{HIGH}	HIGH period of the SCL clock		60	-	600	-	ns
t _{SU;DAT}	Data set-up time		10	-	100	-	ns
t _{HD;DAT}	Data hold time		0	70	0	-	ns
t _{rCL}	Rise time of SCL signal		10	40	20*0.1C _b	300	ns
t _{rCL1}	Rise time of SCL signal after a repeated START condition and after an acknowledge bit		10	80	20*0.1C _b	300	ns
t _{fCL}	Fall time of SCL signal		10	40	20*0.1C _b	300	ns
t _{rDA}	Rise time of SDA signal		10	80	20*0.1C _b	300	ns
t _{fDA}	Fall time of SDA signal		10	80	20*.01C _b	300	ns
t _{SU;STO}	Set-up time for STOP condition		160	-	600	-	ns
t _{BUF}	Bus free time between a STOP and START condition		160	-	1300	-	ns
t _{VD;DAT}	Data valid time		-	160	-	900	ns
t _{VD;ACK}	Data valid acknowledge time		-	160	-	900	ns
C _b	Capacitive load for each bus line	SDA and SCL lines	-	100	-	400	pF

Note 1: All values referred to V_{IH}(min) and V_{IL}(max) levels of I/O stages table.

Note 2: Loads in excess of 100pf will restrict bus operation speed below 3.4MHz



Microsemi®

Operation Theory

Basic Operation

The LX7178 compares V_{OUT} voltage to an internal reference, V_{REF}. When V_{OUT} is lower than V_{REF}, the upper switch turns on and the lower switch turns off. When V_{OUT} is higher than V_{REF}, the upper switch turns off and the lower switch turns on. An internal ramp helps to keep the switching frequency constant over a wide range of output capacitor values and parasitic components (i.e. ESR, ESL). In addition, a frequency control loop keeps the switching frequency constant during continuous conduction mode.

At light loads, if enabled, the converter automatically reduces the switching frequency and enters discontinuous conduction to optimize efficiency while ensuring low V_{OUT} ripple voltage.

An integrated I²C bus interface, operating up to 3.4Mbps, adds the following use programmability to the converter:

1. On the fly programming of the output voltage in 4.7mV increments.
2. Enable / Disable the regulator.
3. Allow PSM or limit operation to only PWM mode.
4. Set the V_{REF} slew rate.
5. Switch node slew rate control.

Setting the Output Voltage

The reference voltage is programmed with the I²C bus VSEL register value.

$$V_{REF} = 0.6V + N_{SEL} \cdot 0.0046875 V \quad (2)$$

Where N_{SEL} is the decimal value of the 7 VSEL bits.

Startup

If the LX7178 is enabled, when VIN rises above the UVLO threshold, the regulator will initiate a startup sequence. The serial port registers are initialized to their default values and all internal bias voltages and currents are allowed to stabilize. V_{REF} then ramps up from 0V to the default voltage at the default slew rate. At the end of the ramp time, PGOOD is allowed to go high 45ms after V_{OUT} has reached the PGOOD rising threshold. During the ramp time, the LX7178 switches to PSM to allow discontinuous operation. This switchover is independent of the MODE bit setting.



Microsemi®

Operation Theory (Continued)

Over Current Protection

The LX7178 protects against all types of short circuit conditions. Cycle by cycle over current protection turns off the upper switch when the current exceeds the OCP threshold. When this occurs, the upper switch is held off for at least 200ns before being allowed to turn on again. After startup, if V_{OUT} drops below the V_{OUT} under voltage threshold, a hiccup sequence will be initiated where both output switches are shut off for 1.5ms before initiating another soft start cycle. This protects against a crowbar short circuit. The V_{OUT} under voltage detection is not active during start up.

Positive Voltage Transitions

After the initial start up sequence, the output voltage can be programmed to a new value by programming the VSEL register bits and then asserting the GO bit. V_{REF} will transition to the new value at the programmed slew rate. The PGOK monitor bit is deasserted during the V_{REF} ramp time, or when V_{OUT} is outside the error envelope.

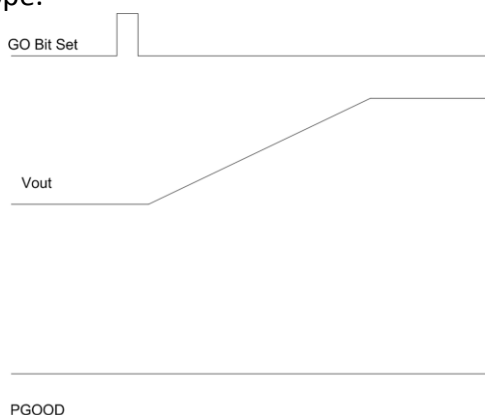

Figure 18: Positive Voltage Transition

Negative Voltage Transitions

A negative voltage transition occurs when a lower output voltage is programmed into the VSEL register, and initiated by asserting the GO bit. In PSM, the LX7178 will not discharge the output filter capacitor.

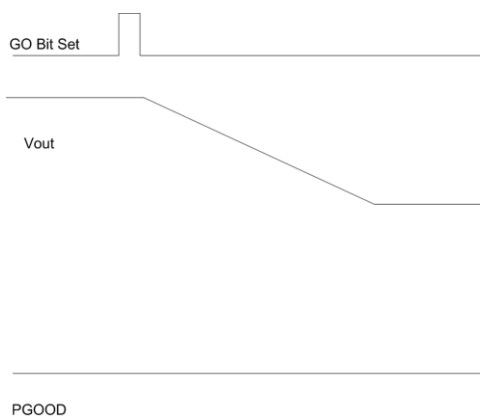

Figure 19: Negative Voltage Transition

Enabling Regulator from I²C Bus

In addition to the EN pin, the regulator can be enabled and disabled via the I²C bus by programming the control register. During disable, the regulator and most of the support circuitry is turned off. However, the I²C bus circuitry is still active and may be programmed.

Switch Node Rise Rate Adjustment

The LX7178 can be programmed to operate in a lower emissions mode by slowing down the switch node rise rate. In this mode, the switch node rise rate will slow down 25%, reducing the switching frequency harmonic content.

3V to 5.5V, 5A Constant Frequency Hysteretic Synchronous Buck Regulator with I²C Production Datasheet



Microsemi

I²C Interface

I²C Port Functional Description

- Simple two wire, bidirectional, serial communication port.
- Multiple devices on same bus speeds from 400Kbps (FS-Mode) to 3.4Mbps (HS-Mode).
- SOC Master controls bus.
- Device listens for the unique address that precedes data.

General I²C Port Description

The LX7178 includes an I²C compatible serial interface, using two dedicated pins: SCL and SDA for I²C clock and data respectively. Each line is externally pulled up to a logic voltage when they are not being controlled by a device on the bus. The LX7178 interface acts as a I²C slave that is clocked by the incoming SCL clock. The LX7178 I²C port will support both the Fast mode (400kHz max) and typically the High Speed mode (3.4MHz max). The data on the SDA line must be stable during the HIGH period of the clock signal (SCL). The state of the SDA line can only be changed when SCL is LOW (except for start, stop, and restart).

Register Map

The LX7178 has five 8-bit user-accessible registers. See Control Register Bit Definition.

Slave Address

In the table below, the A1 and A0 are the binary value of the address given in the ordering information shown on page 3.

7	6	5	4	3	2	1	0
0	0	0	1	1	A1	A0	R/W

Table 1: I²C Slave Address

START and STOP Commands

When the bus is idle, both SCL and SDA must be high except in the power up case where they may be held high or low during the system power up sequence.

The STX SOC (bus master) signals START and STOP bits signify the beginning and the end of the I²C transfer. The START condition is defined as the SDA signal transitioning from HIGH to LOW while the SCL line is HIGH. The STOP condition is defined as the SDA transitioning from LOW to HIGH while the SCL is HIGH. The STX SOC acts as the I²C masters and always generates the START and STOP bits. The I²C bus is considered to be busy after START condition and free after STOP condition. During data transfer, STX SOC master can generate repeated START conditions. The START and the repeated START conditions are functionally equivalent.



Microsemi®

I²C Interface (Continued)

Data Transfers

Data is transferred in 8 bit bytes by SDA with the MSB transferred first. Each byte of data has to be followed by an acknowledge (ACK) bit. The acknowledged related clock pulse is generated by the master. The acknowledge occurs when the transmitter master releases the SDA line to a high state during the acknowledge clock. The SDA line must be pulled down by the receiver slave during the 9th clock pulse to signify acknowledgment. A receiver slave which has been addressed must generate an acknowledgement (“ACK”) after each byte has been received.

After the START condition, the STX SOC (I²C) master sends a chip address. The standard I²C address is seven bits long. Making the eighth bit a data direction bit (R/W). For the eighth bit (LSB), a “0” indicates a WRITE and a “1” indicates a READ. (For clarification, communications are broken up into 9-bit segments, one byte followed by one bit for acknowledging.) The second byte selects the register to which the data will be written. The third byte contains data to write to the selected register.

When a receiver slave doesn’t acknowledge the slave address, the data line must be left HIGH by the slave. The master can then generate a STOP command to abort the transfer. If a slave receiver does acknowledge the slave address but, sometime later in the transfer cannot receive any more data bytes, the master must again abort the transfer. This is indicated by the slave generating the not acknowledge on the first byte to follow.

The slave leaves the data line HIGH and the master generates the STOP command. The data line is also left high by the slave and master after a slave has transmitted a byte of data to the master in a read operation, but this is a not acknowledge that indicates that the data transfer is successful.

Data Transfer Timing for Write Commands

In order to help assure that bad data is not written into the part, data from a write command is only stored after a valid STOP command has been performed.

I²C Electrical Characteristics

The minimum HIGH and LOW periods of the SCL clock specified the I²C Timing Specification table determine the maximum bit transfer rates of, 400 kbit/s for Fast-mode devices, and 3.4 Mbits/s for HS-mode Plus. Devices must be able to follow transfers at their own maximum bit rates, either by being able to transmit or receive at that speed or by applying the I²C clock synchronization procedure, which will force the master into a wait state and stretch the LOW period of the SCL signal. Of course, in the latter case the bit transfer rate is reduced.

Figures 22 and Figure 23 show all timing parameters for the HS & FS-mode timing. The ‘normal’ START condition S does not exist in HS-mode. Timing parameters for Address bits, R/W bit, Acknowledge bit and DATA bits are all the same. Only the rising edge of the first SCL clock signal after an acknowledge bit has a larger value because the external Rp has to pull-up SCL without the help of the internal current-source.



Microsemi

I²C Interface (Continued)

The HS & FS-mode timing parameters for the bus lines are specified in the I²C Timing Specification Table. The minimum HIGH and LOW periods and the maximum rise and fall times of the SCL clock signal determine the highest bit rate.

With an internally generated SCL signal with LOW and HIGH level periods of 200ns and 100ns respectively, an HS-mode master fulfills the timing requirements for the external SCL clock pulses (taking the rise and fall times into account) for the maximum bit rate of 3.4Mbit/s. So a basic frequency of 10MHz, or a multiple of 10MHz, can be used by an HS-mode master to generate the SCL signal. There are no limits for maximum HIGH and LOW periods of the SCL clock, and there is no limit for a lowest bit rate.

Timing parameters are independent for capacitive load up to 100pF for each bus line allowing the maximum possible bit rate of 3.4Mbit/s. At a higher capacitive load on the bus lines, the bit rate decreases gradually. The timing parameters for a capacitive bus load of 400pF are specified in I²C Timing Specification Table, allowing a maximum bit rate of 1.7Mbit/s. For capacitive bus loads between 100pF and 400pF, the timing parameters must be interpolated linearly. Rise and fall times are in accordance with the maximum propagation time of the transmission lines SDA and SCL to prevent reflections of the open ends.

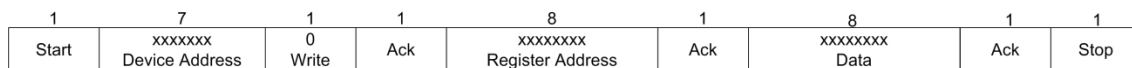

Figure 20: Write Protocol



Figure 21: Read Protocol



Microsemi

I²C Interface (Continued)

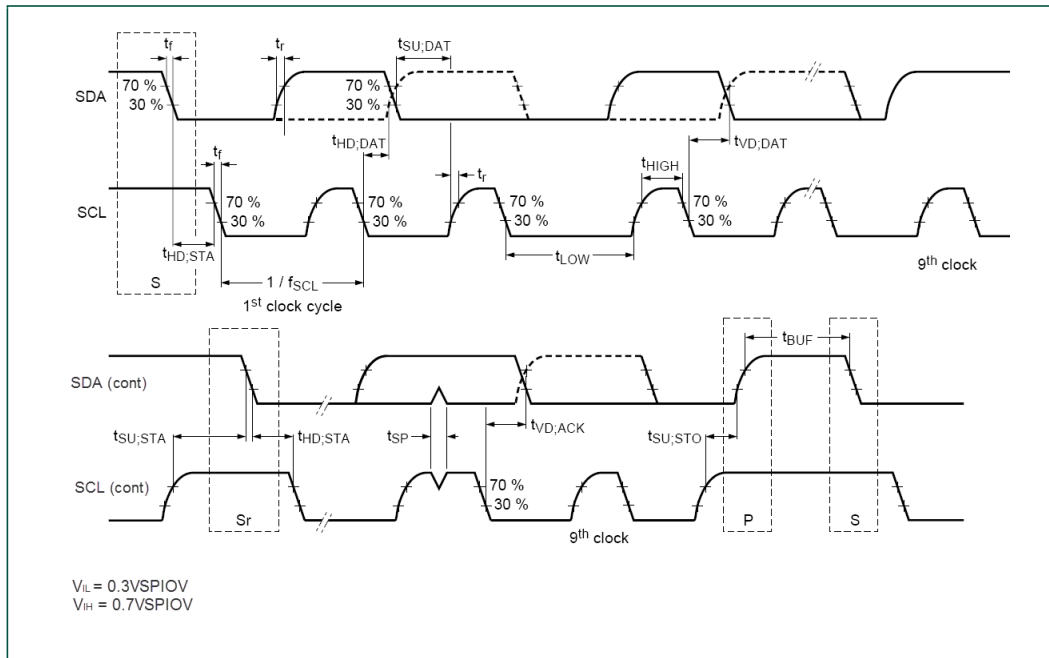

Figure 22: Definition for FS-Mode devices on the I²C Port

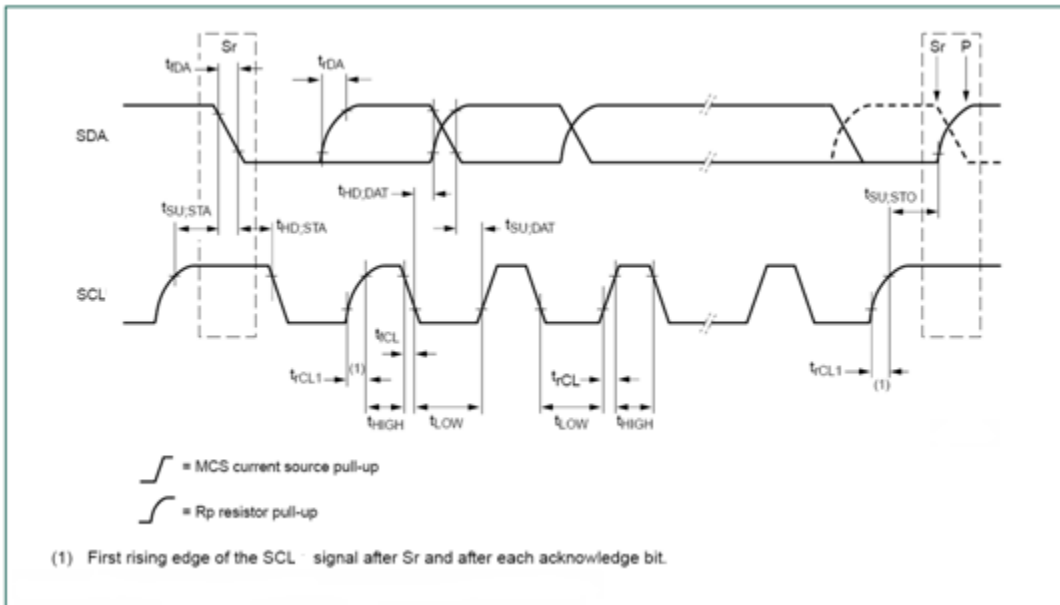

Figure 23: Timing definition for HS-mode devices on the I²C Port



Microsemi®

I²C Interface (Continued)

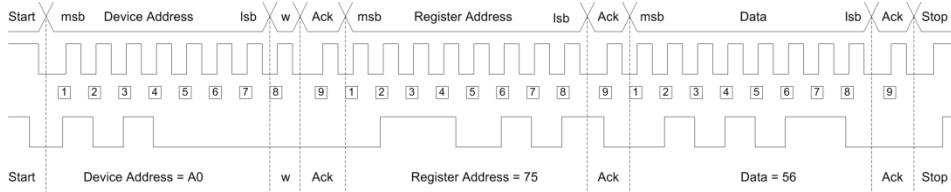

Figure 24: Write Cycle Diagram

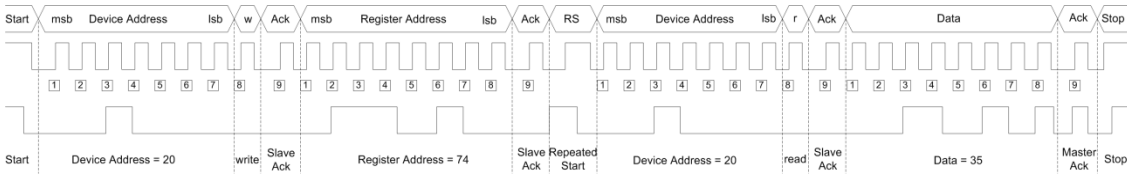

Figure 25: Read Cycle Diagram

Control Register Bit Definition

Bit	Name	Value	Description
Status, Address 00h			
7:3	Reserved		
2	OCP		Latched to 1 if the over current limit is reached. Write a "1" to reset the status flag.
1	OTP		Latched to 1 if an over temperature event occurs. Write a "1" to reset the status flag.
0	FB_UVLO		Latched to 1 if a FB_UVLO event occurs. Write a "1" to reset the status flag.
Vsel, Address 01h, (aka dac)			
7	EN	1-d	Device enabled.
		0	Device disabled.
6:0	VSEL[6:0]		7-bit DAC value to set V _{REF} . The default value is determined by the part ordering code.

3V to 5.5V, 5A Constant Frequency Hysteretic Synchronous Buck Regulator with I²C Production Datasheet



Microsemi

Bit	Name	Value	Description
Ctrl1, Address 02h, (aka reg2)			
7:6	Reserved	00-d	
5	DLY_DIS	1-d	Disable 45ms delay on PGOOD.
		0	45ms delay on PGOOD is enabled.
4	ctrl1	0-d	TBD
3	SW_RATE	1-d	Normal high efficiency rise rate.
		0	Reduced switch node rise rate.
2	Reserved	1-d	
		0	
1	Reserved	1-d	
		0	
0	MODE	1	PWM mode only – NO PSM.
		0-d	Power Save Mode – allows discontinuous conduction.
Vendor ID, Address 03h (Read Only)			
7:4	VID[7:0]	0010	Microsemi Vendor ID .
3:2	A1A0	00	Designates the slave address version. These bits will correspond to the two LSB bits.
1:0	VOUT	00	Designates the default output voltage version, 00=0.6V, 01=0.8V, 10=0.9V, 11=0.975V.
Ctrl2, Address 04h, (aka reg4)			
7:6	Reserved		
5	GO	1	Writing to this bit starts a VOUT transition regardless of its initial value.
		0-d	The VOUT is ramped to the default VSEL Value.
4	Discharge	1	When the regulator is disabled, the output voltage is discharged through the SW pin.
		0-d	When the regulator is disabled, the output voltage is not discharged.
3	PGOK (read only)	1	Is high when output is in regulation and V _{REF} has stabilized.
		0	Is low during a output voltage transition or when the output is not in regulation.
2:0	SLEW	000	Reserved.
		001	Reserved.
		010	VOUT slews at 2mv/μs.
		011-d	VOUT Slews at 4mV/μs; this is the default setting.
		100	VOUT slews at 8mV/μs.
		101	VOUT slews at 16mv/μs.
		110	VOUT slews at 32mv/μs.
		111	VOUT slews at 64mV/μs.

Note: -d is the default value at startup.



Microsemi

Package Dimensions

WLCSP 20 Ball 0.4mm Pitch

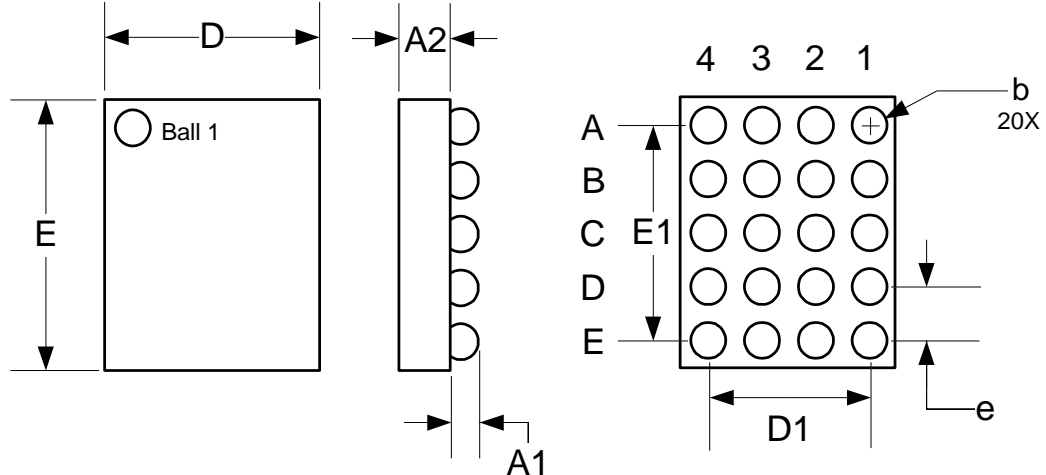

Dim	MILLIMETERS		INCHES	
	MIN	MAX	MIN	MAX
A1	0.186	0.226	0.0073	0.0089
A2	0.360	0.400	0.0142	0.0157
b	0.240	0.280	0.0094	0.0110
D1	1.20 BSC		0.0472 BSC	
D	1.630		0.0642	
e	0.40 BSC		0.0157 BSC	
E1	1.60 BSC		0.0630 BSC	
E	2.045		0.0805	

Note:
1. Solder ball composition SnAgCu

PRODUCTION DATA – Information contained in this document is proprietary to Microsemi and is current as of publication date. This document may not be modified in any way without the express written consent of Microsemi. Product processing does not necessarily include testing of all parameters. Microsemi reserves the right to change the configuration and performance of the product and to discontinue product at any time.

X-ON Electronics

Largest Supplier of Electrical and Electronic Components

Click to view similar products for [Switching Voltage Regulators](#) category:

Click to view products by [Microsemi](#) manufacturer:

Other Similar products are found below :

[FAN53610AUC33X](#) [FAN53611AUC123X](#) [FAN48610BUC33X](#) [FAN48610BUC45X](#) [FAN48617UC50X](#) [R3](#) [430464BB](#) [MIC45116-1YMP-T1](#) [KE177614](#) [MAX809TTR](#) [NCV891234MW50R2G](#) [NCP81103MNTXG](#) [NCP81203PMNTXG](#) [NCP81208MNTXG](#) [NCP81109GMNTXG](#) [SCY1751FCCT1G](#) [NCP81109JMNTXG](#) [AP3409ADNTR-G1](#) [LTM8064IY](#) [LT8315EFE#TRPBF](#) [NCV1077CSTBT3G](#) [XCL207A123CR-G](#) [MPM54304GMN-0002](#) [MPM54304GMN-0003](#) [XDPE132G5CG000XUMA1](#) [DA9121-B0V76](#) [LTC3644IY#PBF](#) [MP8757GL-P](#) [MIC23356YFT-TR](#) [LD8116CGL](#) [HG2269M/TR](#) [OB2269](#) [XD3526](#) [U6215A](#) [U6215B](#) [U6620S](#) [LTC3803ES6#TR](#) [LTC3803ES6#TRM](#) [LTC3412IFE](#) [LT1425IS](#) [MAX25203BATJA/VY+](#) [MAX77874CEWM+](#) [XC9236D08CER-G](#) [ISL95338IRTZ](#) [MP3416GJ-P](#) [BD9S201NUX-CE2](#) [MP5461GC-Z](#) [MPQ4415AGQB-Z](#) [MPQ4590GS-Z](#) [MCP1603-330IMC](#)