

MMA053AA

Datasheet

DC–8 GHz 1 W GaAs MMIC pHEMT Distributed Power

Amplifier

Released

May 2017



Power Matters.™

Contents

1	Revision History	1
1.1	Revision 1.0	1
2	Product Overview	2
2.1	Applications	2
2.2	Key Features	2
3	Electrical Specifications	3
3.1	Absolute Maximum Ratings	3
3.2	Specified Electrical Performance	3
3.3	Typical Performance Curves	3
4	Chip Outline Specification	7
4.1	Chip Outline Drawing	7
4.2	Die Packaging Information	7
4.3	Bond Pad Information	8
4.4	Assembly Diagram	9
4.5	Applications Information	10
5	Handling and Die Attachment Recommendations	11
6	Ordering Information	12

1 Revision History

The revision history describes the changes that were implemented in the document. The changes are listed by revision, starting with the most current publication.

1.1 Revision 1.0

Revision 1.0 was published in May 2017. It was the first publication of this document.

2 Product Overview

MMA053AA is a gallium arsenide (GaAs) monolithic microwave integrated circuit (MMIC) pHEMT distributed power amplifier die that operates between DC and 8 GHz. The amplifier provides 17 dB of gain, +43 dBm output IP3, and +31 dBm of output power at 3 dB compression, while requiring only 410 mA from a 11 V supply. Gain flatness over the DC to 8 GHz frequency range varies by only ± 0.5 dB, making the MMA053AA die ideal for EW, ECM, radar, and test equipment applications. The MMA053AA amplifier features compact die size and I/Os that are internally matched to 50 Ω , facilitating easy integration into multi-chip modules (MCMs).

The following figure is a functional block diagram for the MMA053AA device.

Figure 1 • Functional Block Diagram

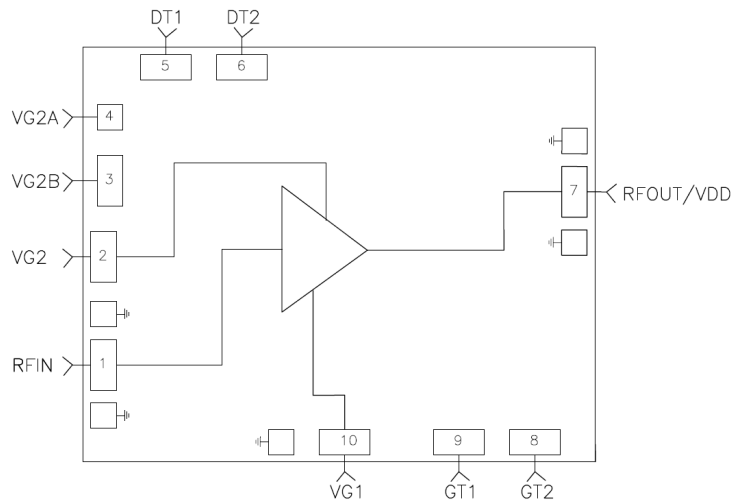

2.1 Applications

The MMA053AA device is designed for the following applications:

- Test instrumentation
- Telecom infrastructure
- Microwave radio and VSAT
- Microwave communications

2.2 Key Features

The following are key features of the MMA053AA device:

- Frequency range: DC to 8 GHz
- High P3dB output power: 31 dBm
- Gain: 17 dB
- High OIP3: 43 dBm
- Bias $V_{DD} = 11$ V/ 410 mA, $V_G = -0.7$ V
- 50 Ω matched I/O
- Compact die size: 3 mm \times 2.25 mm \times 0.07 mm

3 Electrical Specifications

This section details the electrical specifications of the MMA053AA device.

3.1 Absolute Maximum Ratings

This following table shows the absolute maximum ratings of the MMA053AA device.

Table 1 • Absolute Maximum Ratings

Parameter	Rating
Storage temperature	–65 °C to 150 °C
Operating temperature	–55 °C to 85 °C
Drain bias voltage, (V_D)	+12 V
Gate bias voltages, (V_{G1})	0 V
Gate bias voltages, (V_{G2})	+4 V
RF input power (7 dB compression)	TBD
DC power dissipation (T = 85 °C)	5.6 W
Channel temperature	175 °C
Thermal impedance	TBD
ESD sensitivity (HBM)	TBD

3.2 Specified Electrical Performance

The following table shows the specified electrical performance of the MMA053AA device at 25 °C, where V_{DD} is 11 V and I_{DD} is 410 mA. $V_{G1} = -0.7$ V and V_{G2} is not used.

Table 2 • Specified Electrical Performance

Parameter	Frequency Range	Min	Typ	Max	Units
Operational frequency range		DC		8	GHz
Gain	DC–8 GHz		17		dB
Gain flatness	DC–8 GHz		±0.5		dB
Noise figure	2 GHz–8 GHz		3		dB
Input return loss	DC–8 GHz		–17		dB
Output return loss	DC–8 GHz		–15		dBm
P1dB	DC–8 GHz		29		dBm
Psat	DC–8 GHz		31		dBm
OIP3	DC–8 GHz		43		dBm
V_{DD} (drain voltage supply)			11		V
I_{DD} (drain current)			410		mA
V_{G1} (gate voltage supply)			0.7		V

3.3 Typical Performance Curves

The following graphs show the typical electrical performance curves of the MMA053AA device at 25 °C, where V_{DD} is 11 V and there is an on-chip V_{G2} bias.

Figure 2 • Gain and Return Loss vs. Frequency

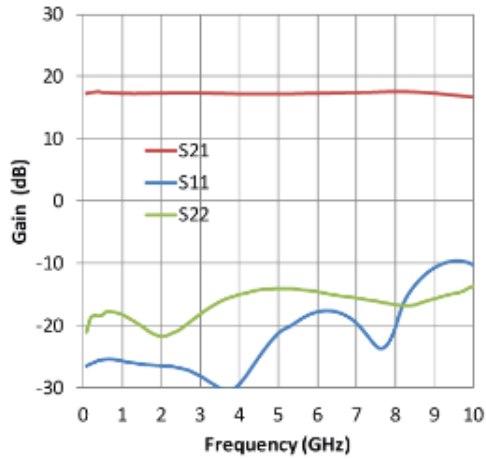

Figure 3 • Gain vs. Temperature

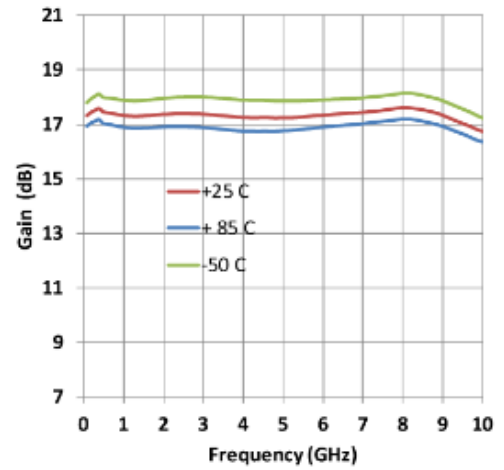

Figure 4 • Input Return Loss vs. Frequency

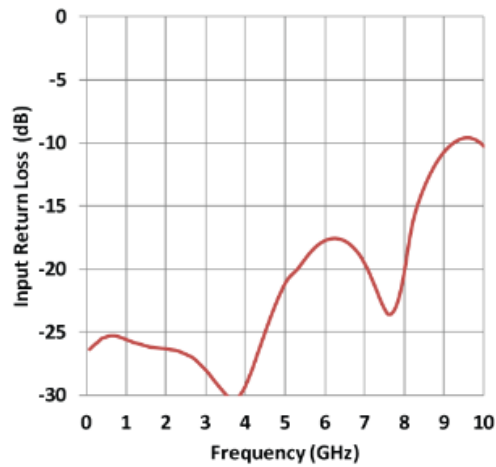

Figure 5 • Input Return Loss vs. Temperature

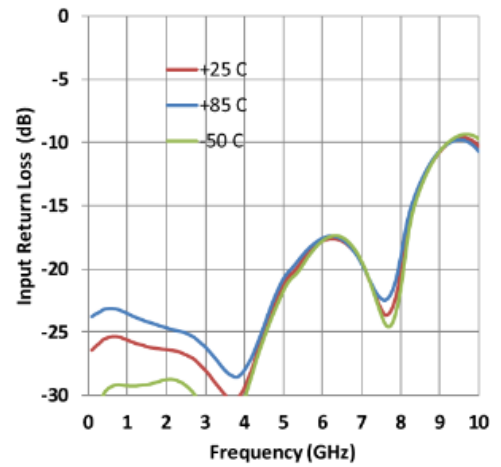

Figure 6 • Noise Figure vs. Frequency

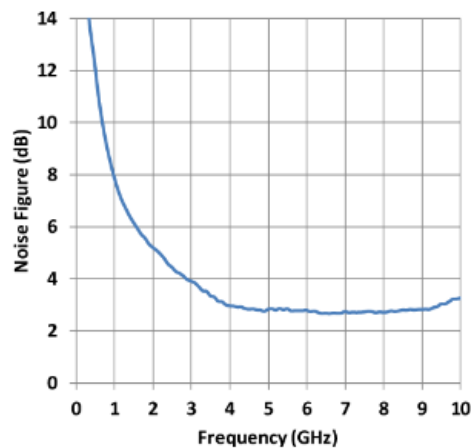

Figure 7 • Noise Figure vs. Temperature

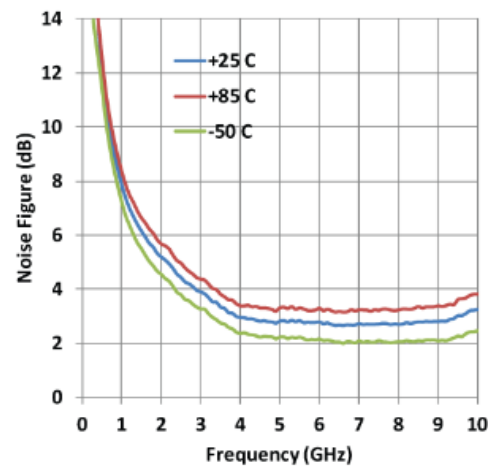

Figure 8 • Output Return Loss vs. Frequency

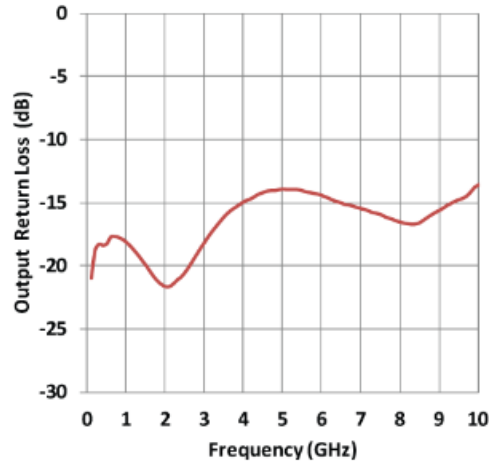

Figure 9 • Output Return Loss vs. Temperature

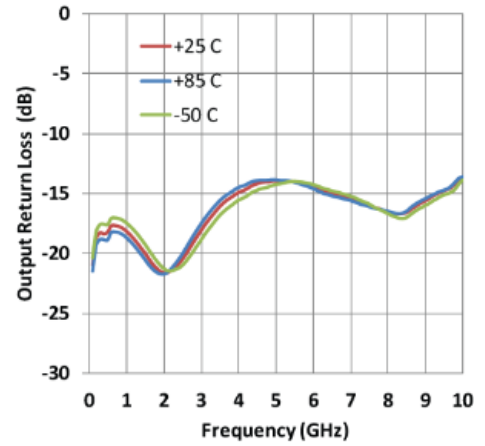

Figure 10 • Isolation vs. Frequency

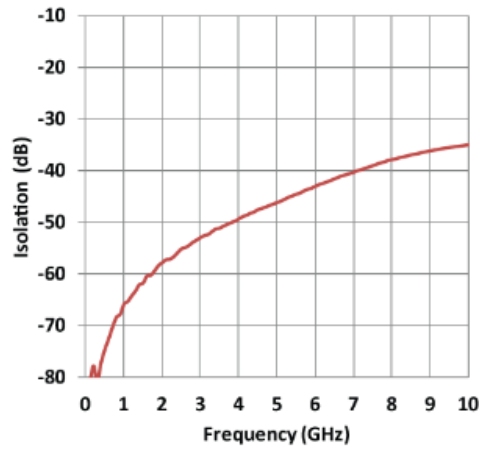

Figure 11 • Isolation vs. Temperature

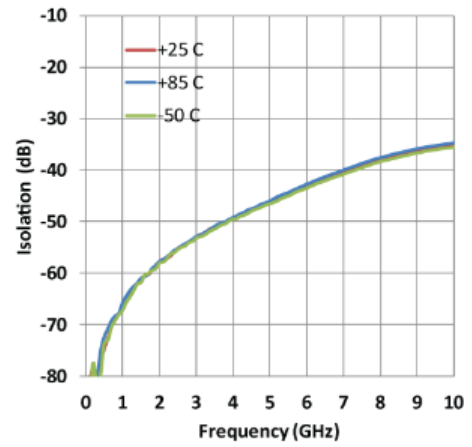

Figure 12 • OIP3 vs. Frequency

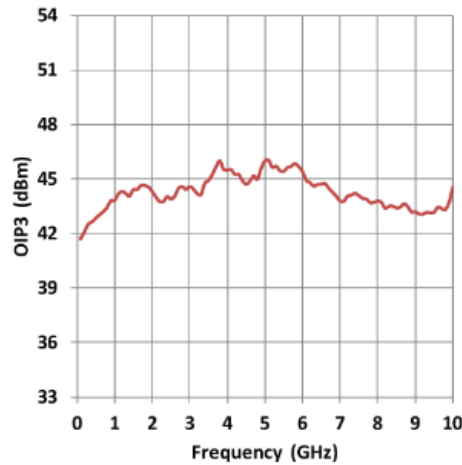

Figure 13 • OIP3 vs. Temperature

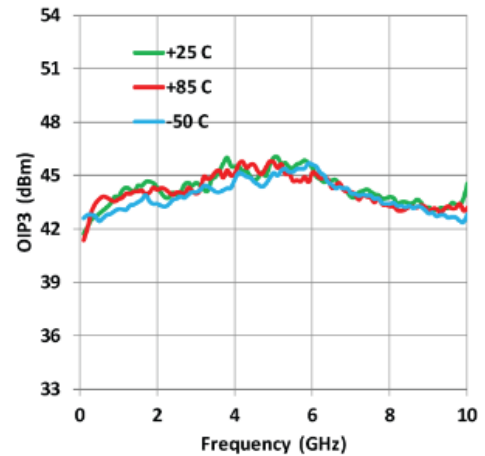

Figure 14 • P1dB vs. Frequency

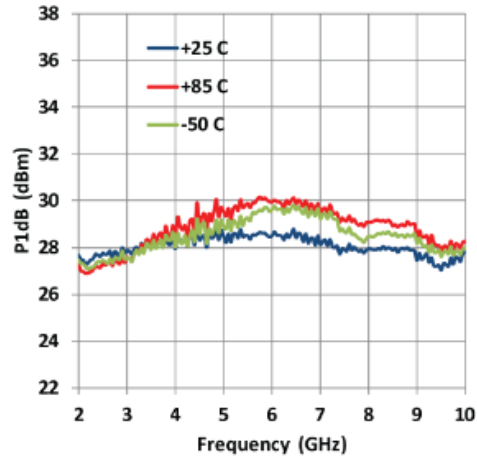
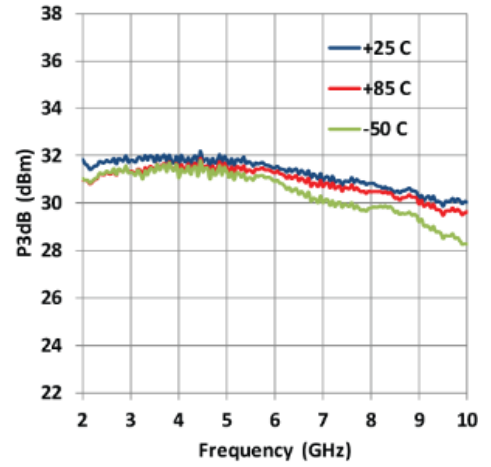

Figure 15 • P3dB vs. Frequency



4 Chip Outline Specification

This section details the chip outline specifications of the MMA053AA device.

4.1 Chip Outline Drawing

The following illustration shows the package outline of the MMA053AA device. Dimensions are in millimeters [inches].

Figure 16 • Chip Outline Drawing

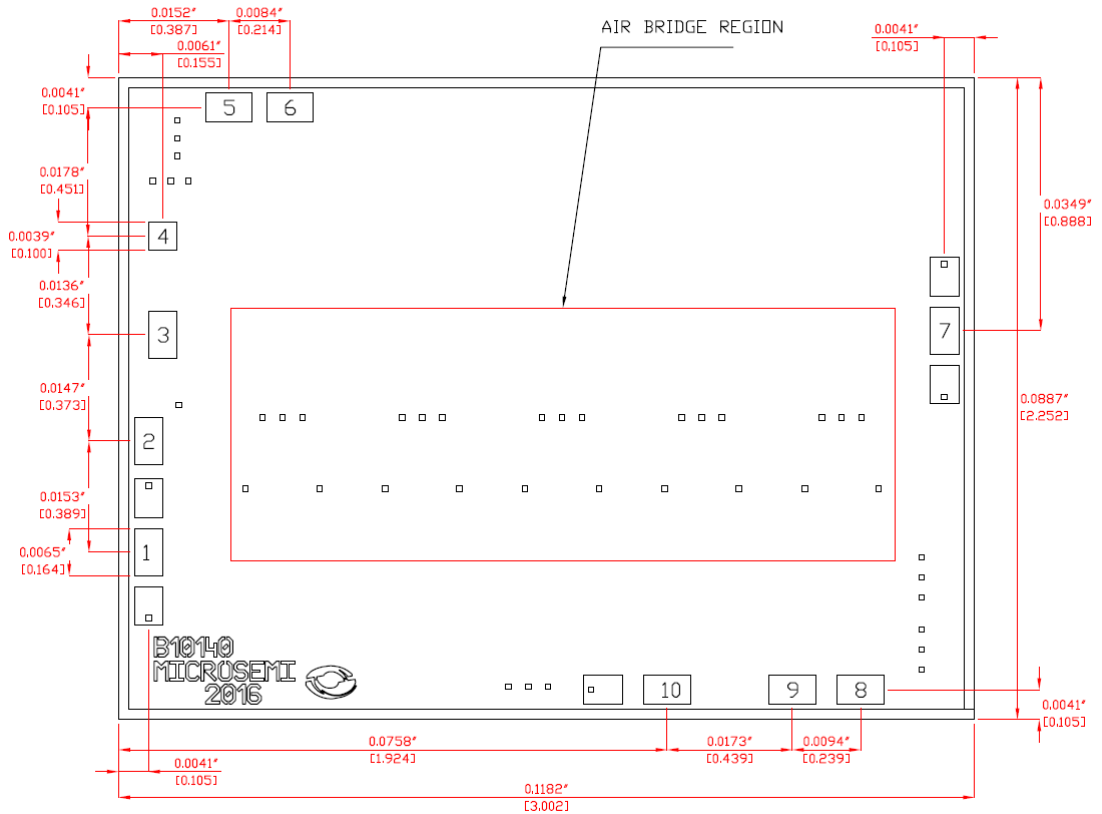

4.2 Die Packaging Information

The following table lists the die package information of the MMA053AA device. Contact your Microsemi sales representative for additional packaging information

Standard Format	Optimal Format
Waffle pack	Gel pack
50–100 pieces per pack	50 pieces per pack

4.3 Bond Pad Information

The following table lists the bond pad information of the MMA053AA device.

Table 3 • Bond Pad Information

Bond Pad Number	Bond Pad Name	Description
1	RFIN	This pad is AC/DC-coupled and matched to 50 Ω . External large DC blocking capacitor is required to extend performance to very low-frequencies.
2	VG2	External positive Gate 2 control (Optional) for amplifier. Please follow “MMIC Amplifier Biasing Procedure” application note. See application circuit/assembly for required external components.
3	VG2B	DC output for on-chip VG2 bias network. Must be connected to VG2 if on-chip VG2 bias network is to be used, otherwise no connection is required.
4	VG2A	DC input for on-chip VG2 bias network. Must be connected to DT1 if on-chip VG2 bias network is to be used, otherwise no connection is required.
5,6	DT1, DT2	Low-frequency drain termination. Attach external bypass capacitors as per application circuit.
7	RFOUT/VDD	This pad is AC/DC-coupled and matched to 50 Ω . External V_{DD} bias network is required to provide I_{DD} as per the application circuit
8,9	GT2, GT1	Low-frequency gate termination. Attach external bypass capacitors as per application circuit.
10	VG1	Negative Gate 1 control for amplifier. Please follow “MMIC Amplifier Biasing Procedure” application note. See application circuit/assembly for required external components.
Die Bottom	RF/DC ground	Die bottom must be connected to external RF/DC ground on carrier.

4.4 Assembly Diagram

The following illustration shows the assembly diagram of the MMA053AA device. The carrier plate is gold plated. It is necessary to attach components using conductive epoxy. The bypass chip caps are ceramic and must be assembled within 10 mils of the die. Use 1 mil Au bond wires.

Figure 17 • Assembly Diagram RF Probing With On-Chip VG2 Bias Configuration

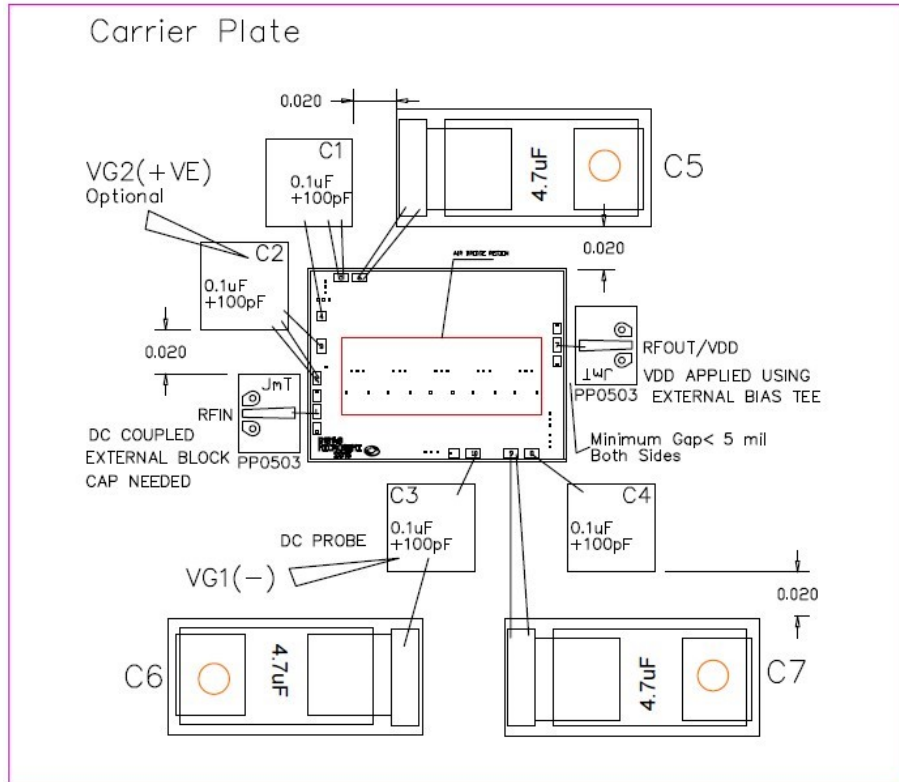

Notes:

1. Attach components on carrier plate using conductive epoxy.
2. VG2A connected to DT1 and VG2B connected to VG2 for on-chip VG2 bias. Disconnect to apply external VG2 bias.
3. Use 1 mil Au bond wires.
4. C1, C2, C3, C4: Presidio VB series dual cap P/N: MVB4040X104MEK5C1B
C5, C6, C7: 4.7 μ F on PCB insert.

4.5 Applications Information

The following illustration shows applications information for the MMA053AA device

Figure 18 • Application Circuit Schematic

APPLICATION CIRCUIT SCHEMATIC With On-Chip VG2 Bias Configuration

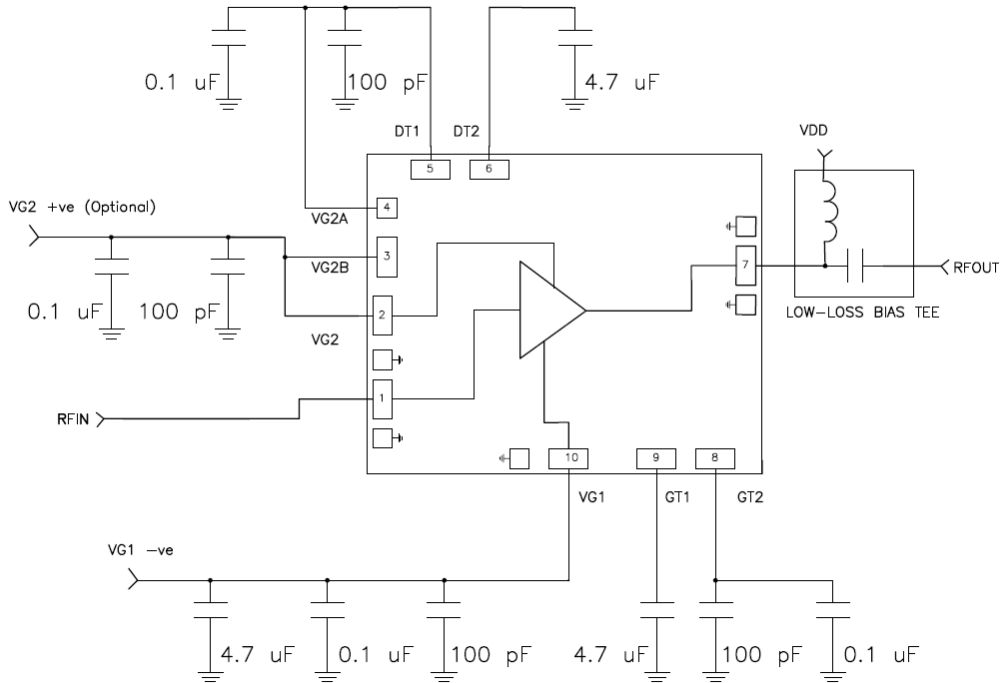

5 Handling and Die Attachment Recommendations

Gallium arsenide integrated circuits are sensitive to electrostatic discharge (ESD) and can be damaged by static electricity. It is recommended to follow all procedures and guidelines outlined in the Microsemi application note [AN01 GaAs MMIC Handling and Die Attach Recommendations](#).

6 Ordering Information

The following table lists the ordering information for the MMA053AA device.

Table 4 • Ordering Information

Part Number	Package
MMA053AA	Die in wafer or GEL pack

**Microsemi Corporate Headquarters**

One Enterprise, Aliso Viejo,
 CA 92656 USA
 Within the USA: +1 (800) 713-4113
 Outside the USA: +1 (949) 380-6100
 Fax: +1 (949) 215-4996
 Email: sales.support@microsemi.com
www.microsemi.com

© 2017 Microsemi Corporation. All rights reserved. Microsemi and the Microsemi logo are trademarks of Microsemi Corporation. All other trademarks and service marks are the property of their respective owners.

Microsemi makes no warranty, representation, or guarantee regarding the information contained herein or the suitability of its products and services for any particular purpose, nor does Microsemi assume any liability whatsoever arising out of the application or use of any product or circuit. The products sold hereunder and any other products sold by Microsemi have been subject to limited testing and should not be used in conjunction with mission-critical equipment or applications. Any performance specifications are believed to be reliable but are not verified, and Buyer must conduct and complete all performance and other testing of the products, alone and together with, or installed in, any end-products. Buyer shall not rely on any data and performance specifications or parameters provided by Microsemi. It is the Buyer's responsibility to independently determine suitability of any products and to test and verify the same. The information provided by Microsemi hereunder is provided "as is, where is" and with all faults, and the entire risk associated with such information is entirely with the Buyer. Microsemi does not grant, explicitly or implicitly, to any party any patent rights, licenses, or any other IP rights, whether with regard to such information itself or anything described by such information. Information provided in this document is proprietary to Microsemi, and Microsemi reserves the right to make any changes to the information in this document or to any products and services at any time without notice.

Microsemi Corporation (Nasdaq: MSCC) offers a comprehensive portfolio of semiconductor and system solutions for aerospace & defense, communications, data center and industrial markets. Products include high-performance and radiation-hardened analog mixed-signal integrated circuits, FPGAs, SoCs and ASICs; power management products; timing and synchronization devices and precise time solutions, setting the world's standard for time; voice processing devices; RF solutions; discrete components; enterprise storage and communication solutions; security technologies and scalable anti-tamper products; Ethernet solutions; Power-over-Ethernet ICs and midspans; as well as custom design capabilities and services. Microsemi is headquartered in Aliso Viejo, California, and has approximately 4,800 employees globally. Learn more at www.microsemi.com.

X-ON Electronics

Largest Supplier of Electrical and Electronic Components

Click to view similar products for [RF Amplifier](#) category:

Click to view products by [Microsemi](#) manufacturer:

Other Similar products are found below :

[A82-1](#) [BGA622H6820XTSA1](#) [BGA 728L7 E6327](#) [BGB719N7ESDE6327XTMA1](#) [HMC397-SX](#) [HMC405](#) [HMC561-SX](#) [HMC8120-SX](#)
[HMC8121-SX](#) [HMC-ALH382-SX](#) [HMC-ALH476-SX](#) [SE2433T-R](#) [SMA3101-TL-E](#) [SMA39](#) [A66-1](#) [A66-3](#) [A67-1](#) [LX5535LQ](#) [LX5540LL](#)
[MAAM02350](#) [HMC3653LP3BETR](#) [HMC549MS8GETR](#) [HMC-ALH435-SX](#) [SMA101](#) [SMA32](#) [SMA411](#) [SMA531](#) [SST12LP17E-XX8E](#)
[SST12LP19E-QX6E](#) [WPM0510A](#) [HMC5929LS6TR](#) [HMC5879LS7TR](#) [HMC1126](#) [HMC1087F10](#) [HMC1086](#) [HMC1016](#) [SMA1212](#)
[MAX2689EWS+T](#) [MAAMSS0041TR](#) [MAAM37000-A1G](#) [LTC6430AIUF-15#PBF](#) [CHA5115-QDG](#) [SMA70-2](#) [SMA4011](#) [A231](#) [HMC-](#)
[AUH232](#) [LX5511LQ](#) [LX5511LQ-TR](#) [HMC7441-SX](#) [HMC-ALH310](#)