

1A SYNCHRONOUS BUCK SWITCHER WITH FET ON BOARD

Production Datasheet

Pb Free Product
DESCRIPTION

The NX4108-12 is a current mode PWM buck switcher with internal compensation and fixed 1.2V output voltage, can provide up to 1A output current with FET on board. It operates from 2.8V to 5.5V which is ideal for the application with single cell Li-Ion battery as well as other 3.3V input bus supply applications. Switching frequency is fixed 1MHz, small surface mount inductors and capacitors are allowed to use, make it good for portable applications.

NX4108-12 is available in 5-pin SOT23 package.

FEATURES

- 2.8 to 5.5V Input Voltage
- Fixed 1.2V Output Voltage
- 5-pin SOT23 Package
- 1MHz Fixed Frequency PWM Operation
- Internally-compensated Current Mode Controller
- Peak Current Limit with HICCUP Feature and Over Temperature Protection
- Prebias Start-up Operation
- Pb-free and RoHS Compliant

APPLICATIONS

- Li-Ion Battery Operated Portable System
- Cellular Phones
- Portable Applications
- USB Devices

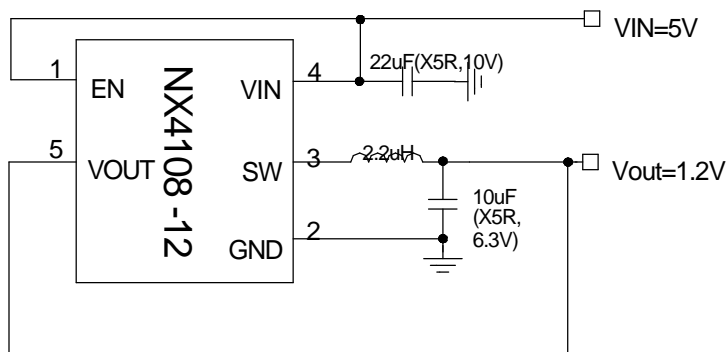
TYPICAL APPLICATION


Figure1 - Typical application of NX4108-12

ORDERING INFORMATION

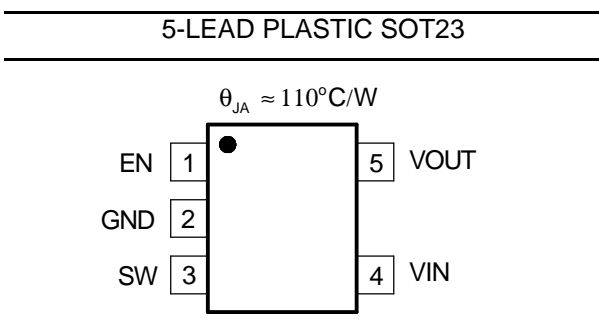
Device	Temperature	Package	Pb-Free
NX4108-12CZ1TR	-40°C to 85°C	SOT23-5L	Yes

ABSOLUTE MAXIMUM RATINGS

VIN to GND	-0.3V to 6V
SW,VOUT,EN to GND	-0.3V to VIN + 0.3V
ESD Susceptibility	1kV
Lead Temperature(Soldering,10sec.)	300°C
Storage Temperature Range	-55°C to 150°C
Operating Junction Temperature Range	-40°C to 150°C

CAUTION: Stresses above those listed in "ABSOLUTE MAXIMUM RATINGS", may cause permanent damage to the device. This is a stress only rating and operation of the device at these or any other conditions above those indicated in the operational sections of this specification is not implied.

PACKAGE INFORMATION



ELECTRICAL SPECIFICATIONS

$V_{IN}=3.5\text{V}$. Typical data refers to $T_A=25^{\circ}\text{C}$. Unless otherwise specified.

PARAMETER	SYM	Test Condition	Min	TYP	MAX	Units
V_{OUT} Voltage						
V _{OUT} Voltage	V _{OUT}		1.168	1.2	1.232	V
Line Regulation						
Line Regulation		VIN=3V to 5V,IOUT=10mA		2		mV
VIN UVLO						
VIN Rising Threshold			2.3	2.5	2.8	V
VIN Falling Threshold				2.3		V
Supply Voltage(VIN)						
VIN Input Voltage Range	V _{IN}		2.8		5.5	V
Shutdown Current	I _{shutdown}	EN=GND		1	5.0	uA
Quiescent Current	I _q	No Load, switching		15		mA
Oscillator (Rt)						
Frequency	F _S		900	1000	1300	kHz
Max Duty Cycle			78	85		%
Min ON time				100		nS
SS						
Soft Start time	T _{ss}			500		uS

PARAMETER	SYM	Test Condition	Min	TYP	MAX	Units
Current Limit						
Current Limit Threshold				1.8		A
Thermal Shutdown						
Thermal shutdown trip point				155		°C
Hysteresis				15		°C
Internal Switch						
Rdson of Control FET		VIN=5V		400		mohm
		VIN=3.3V		480		
Rdson of Synchronous FET		VIN=5V		300		mohm
		VIN=3.3V		360		
Enable						
En low Threshold voltage					0.4	V
En high Threshold voltage			2.0			V

PIN DESCRIPTIONS

PIN SYMBOL	PIN DESCRIPTION
SW	SW output. Junction of the internal high-side and low-side power MOSFETs, and output inductor.
GND	Ground Connection for Chip. Connect GND with large copper areas to the input and output supply returns, and negative terminals of the input and output capacitors.
VOUT	Sense output voltage .
VIN	Supply voltage input for switcher.
EN	Enable input. Set this pin to GND or less than 0.4V will shut down the regulator. Enable signal can not be high when VIN is low.

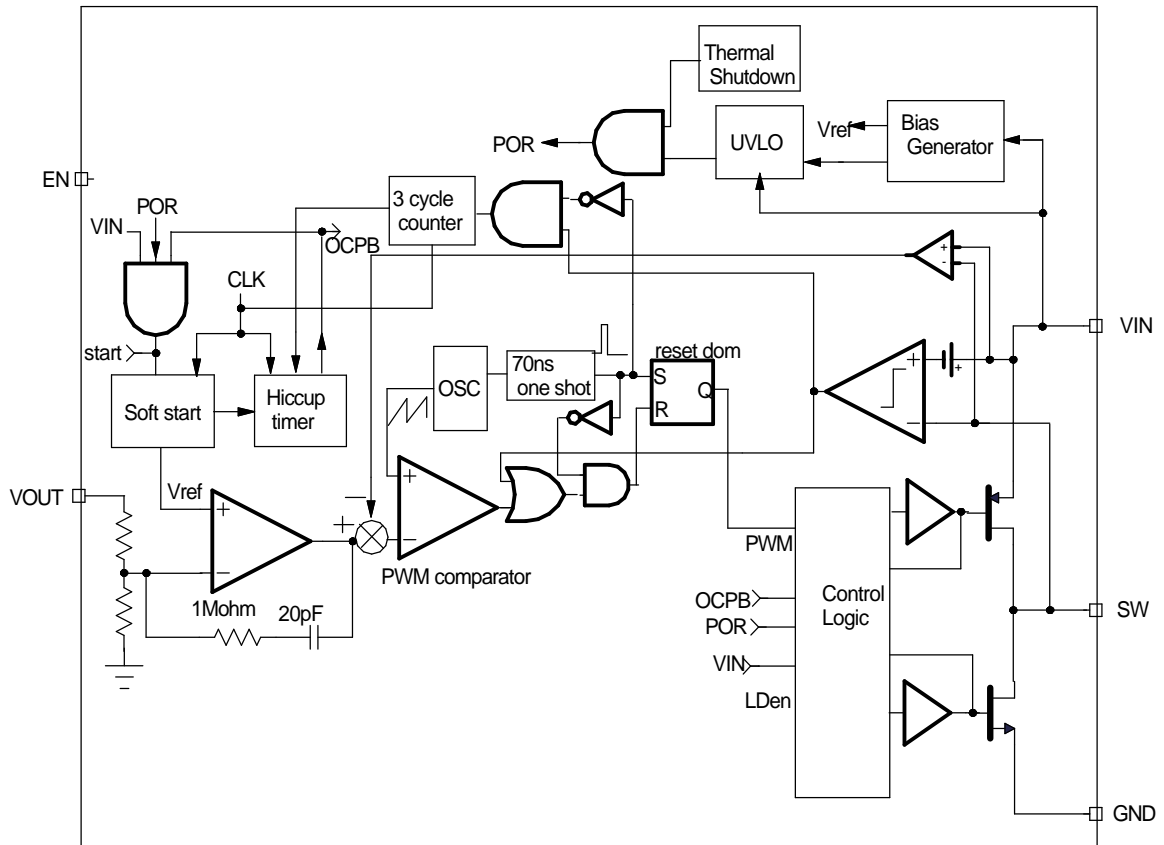
BLOCK DIAGRAM


Figure 2 - Simplified block diagram of the NX4108-12

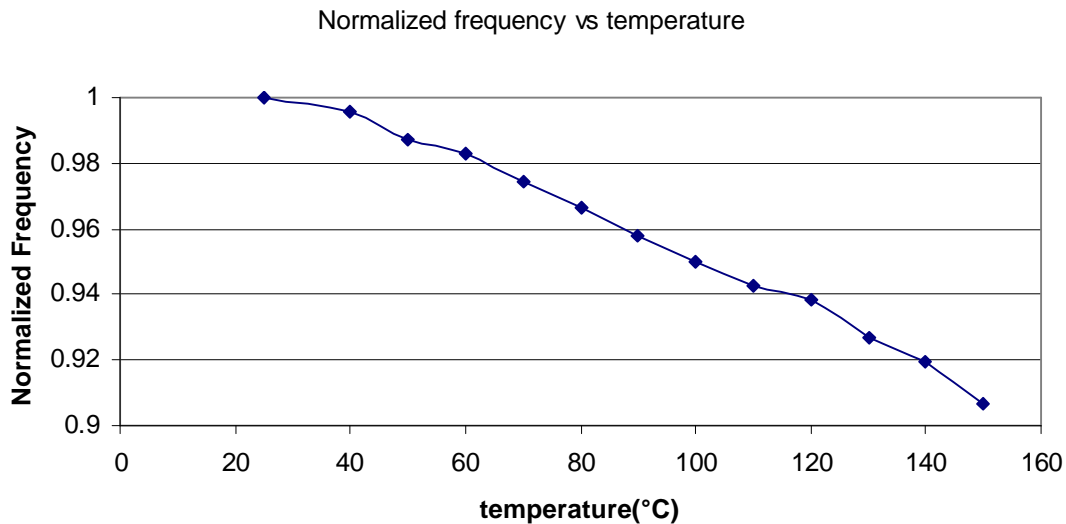
Typical Operating Characteristics

Fig.3- Normalized frequency vs temperature

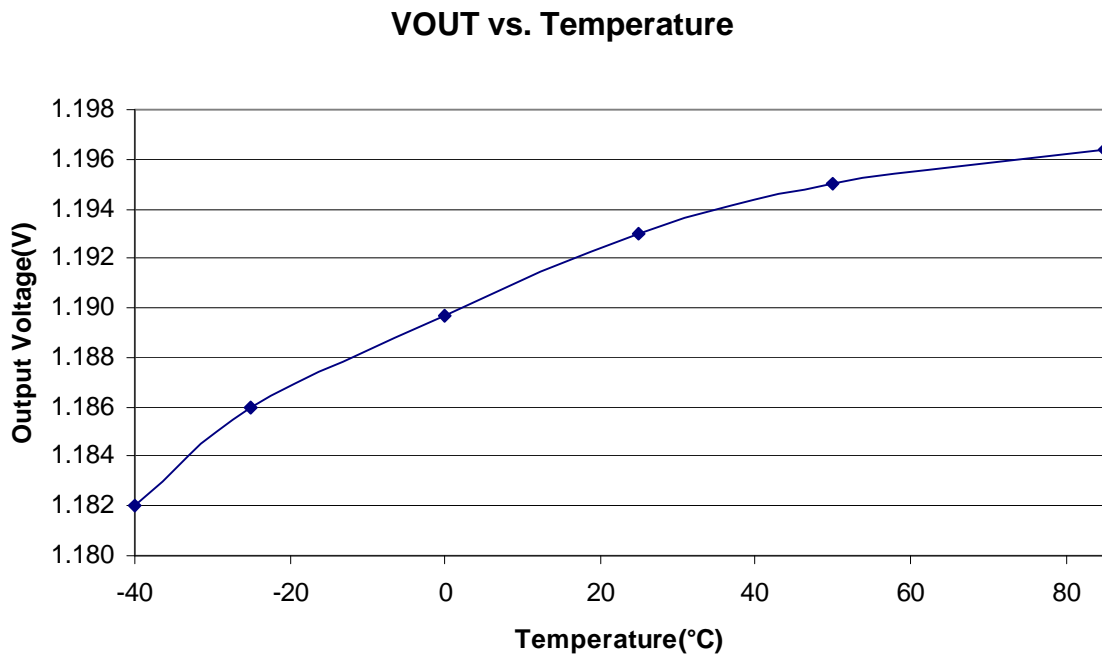


Figure 4 - Output voltage vs temperature(VIN=5V, NO LOAD)

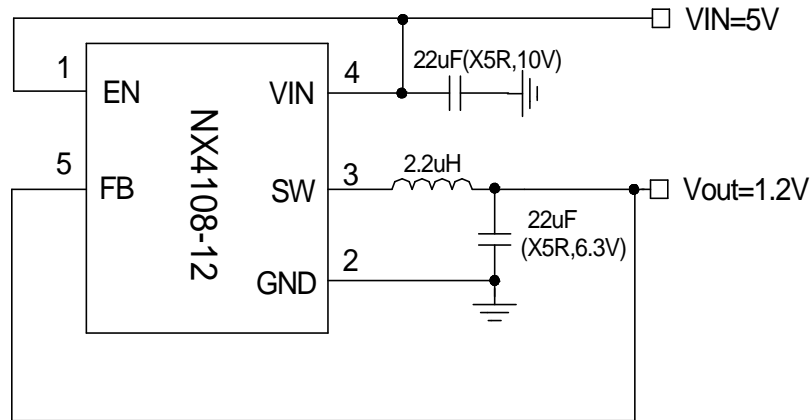
Typical Application


Figure 5 - Demo board schematic

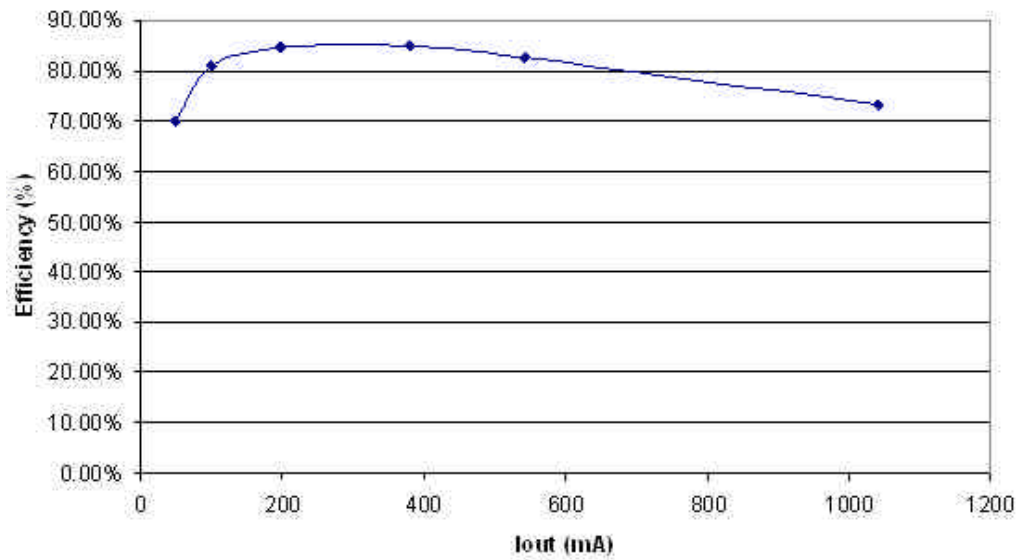


Figure 6 - Efficiency(VIN=5V)

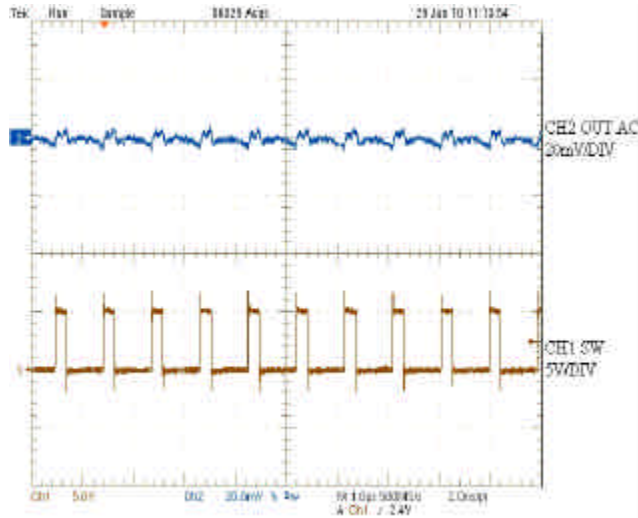
Typical Application Waveforms and Efficiency


Figure 7 - Output ripple

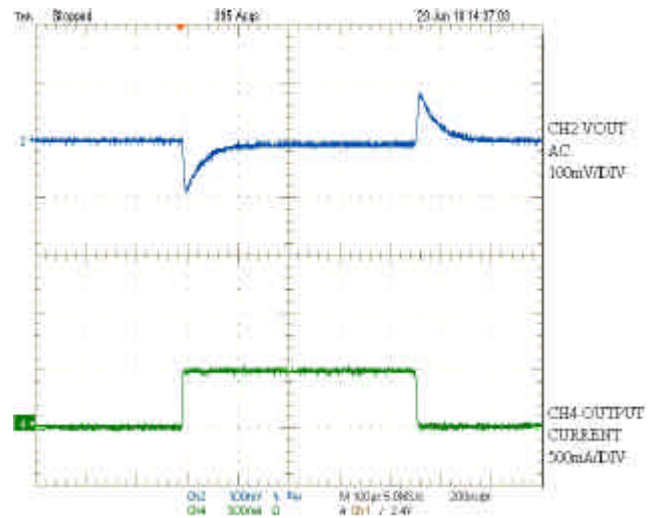


Figure 8 - Transient response

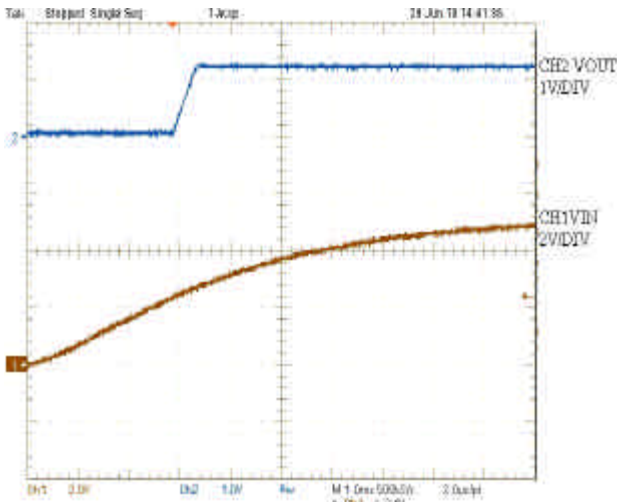


Figure 9 - Startup

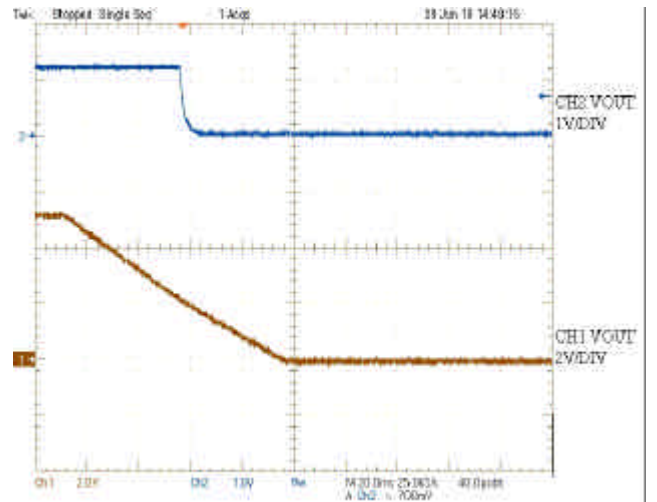


Figure 10 - Shutdown

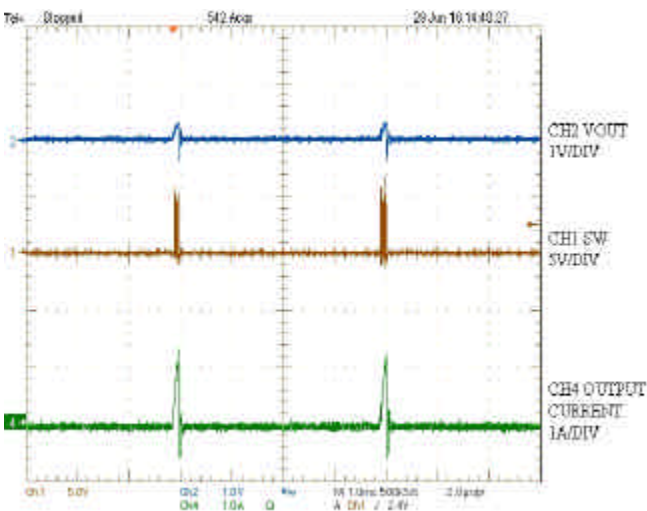
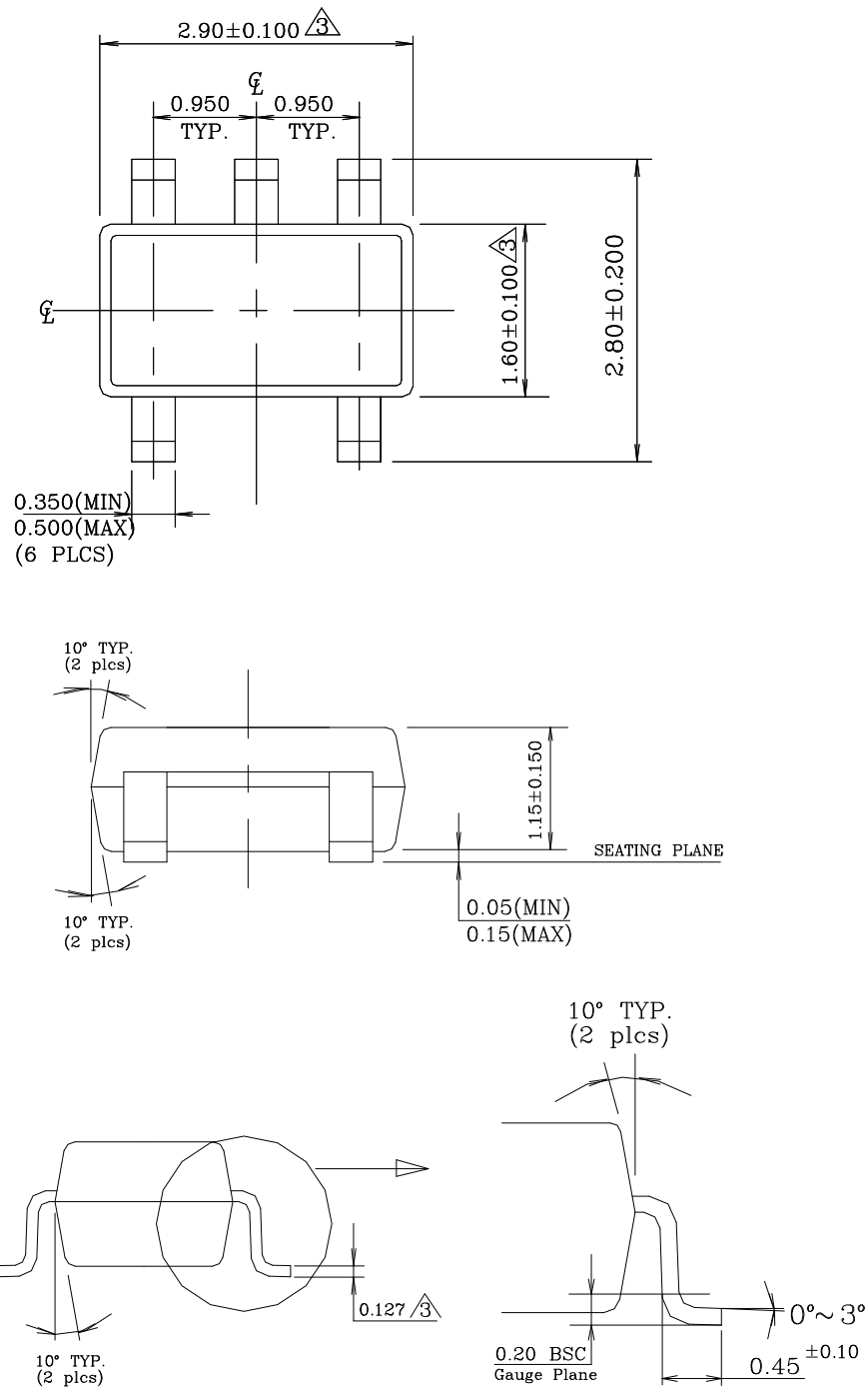


Figure 11 - Output Short

SOT23-5 Outline Dimensions

NOTE:

1. Dimensions and tolerances are as per ANSI Y14.5M, 1982.
2. Package surface to be matte finish VDI 11~13.

$\Delta 3$ Dimensions are exclusive of mold flash and gate burr.

X-ON Electronics

Largest Supplier of Electrical and Electronic Components

Click to view similar products for [Switching Voltage Regulators](#) category:

Click to view products by [Microsemi](#) manufacturer:

Other Similar products are found below :

[FAN53610AUC33X](#) [FAN53611AUC123X](#) [FAN48610BUC33X](#) [FAN48610BUC45X](#) [FAN48617UC50X](#) [R3](#) [430464BB](#) [MIC45116-1YMP-T1](#) [KE177614](#) [MAX809TTR](#) [NCV891234MW50R2G](#) [NCP81103MNTXG](#) [NCP81203PMNTXG](#) [NCP81208MNTXG](#) [NCP81109GMNTXG](#) [SCY1751FCCT1G](#) [NCP81109JMNTXG](#) [AP3409ADNTR-G1](#) [LTM8064IY](#) [LT8315EFE#TRPBF](#) [NCV1077CSTBT3G](#) [XCL207A123CR-G](#) [MPM54304GMN-0002](#) [MPM54304GMN-0003](#) [XDPE132G5CG000XUMA1](#) [DA9121-B0V76](#) [LTC3644IY#PBF](#) [MP8757GL-P](#) [MIC23356YFT-TR](#) [LD8116CGL](#) [HG2269M/TR](#) [OB2269](#) [XD3526](#) [U6215A](#) [U6215B](#) [U6620S](#) [LTC3803ES6#TR](#) [LTC3803ES6#TRM](#) [LTC3412IFE](#) [LT1425IS](#) [MAX25203BATJA/VY+](#) [MAX77874CEWM+](#) [XC9236D08CER-G](#) [ISL95338IRTZ](#) [MP3416GJ-P](#) [BD9S201NUX-CE2](#) [MP5461GC-Z](#) [MPQ4415AGQB-Z](#) [MPQ4590GS-Z](#) [MCP1603-330IMC](#)