CQFP to FBGA Adapter Sockets

Table of Contents

Introduction	1
CQFP to FBGA Adapter Sockets	1
CQFP to FBGA Adapter Socket Assembly Procedure	6
CQ352 to FG484 23x23 Adapter Socket Outline Drawing	11
CQ352 to FG896 Adapter Socket Outline Drawing	12
CQ256 to FG896 Adapter Socket Outline Drawing	13
CQ352 to FG896 Adapter Socket Alignment Pins	13
Reflow Profile	14
Interposer Insertion Limitations	14
High Frequency Signals	15
CQFP to FBGA Adapter Pin Mapping List	16
Prototyped Product, Adapter, and PCB Design Matrix	16
List of Changes	18

Introduction

RTAX™-S/SL devices are radiation-tolerant FPGAs that offer industry-leading advantages for designers of spaceflight systems. The RTAX-S/SL family is a derivative of the Axcelerator® family, with up to two million system gates. The RTAX-S/SL FPGA provides the designer with nearly 250K ASIC gates, with error detection and correction (EDAC) protected static RAM. Microsemi offers the RTAX-S/SL device in two package styles: the ceramic column grid array (CCGA) and ceramic quad flat pack (CQFP).

Microsemi has developed four low cost prototyping methods for RTAX-S/SL devices packaged in a CQFP or CCGA, using the Axcelerator family fine pitch ball grid array (FBGA) or ceramic land grid array (LGA) as a prototyping vehicle:

- CQFP to FBGA adapter socket
- CQFP to LGA adapter socket
- CCGA to FBGA adapter socket
- CCGA to LGA adapter socket

This document describes the adapter sockets for the CQFP and the procedure for assembling them.

Note: These adapters are intended for developing functional prototypes and are not designed for at-speed testing, especially for sensitive I/Os such as LVDS. The intention of the prototyping adapters is to provide functional validation; they may limit the performance of the FPGA.

CQFP to FBGA Adapter Sockets

The CQFP to FBGA adapter sockets have an FBGA configuration on the top and a CQFP configuration on the bottom. The adapter sockets enable customers to use a commercial Axcelerator FG package during prototyping, and then switch to an equivalent CQ256 or CQ352 package for production. There are four CQFP to FBGA adapter sockets available. Their ordering part numbers are listed in [Table 1 on page 2](#).

Table 1 • Adapter Socket Part Number

Adapter Socket	Ordering Part Number	Prototyped and Prototype Device
CQ352 to FG484 23x23	SK-AX250-CQ352RTFG484S	For prototyping RTAX250S/L-CQ352 or AX250-CQ352 using the AX250-FG484 package
CQ352 to FG896	SK-AX1-AX2-KITTOP and SK-AX1-CQ352-KITBTM	For prototyping RTAX1000S/L-CQ352 or AX1000-CQ352 using the AX1000-FG896 package
CQ352 to FG896	SK-AX1-AX2-KITTOP and SK-AX2-CQ352-KITBTM	For prototyping RTAX2000S/L-CQ352 or AX2000-CQ352 using the AX2000-FG896 package
CQ256 to FG896	SK-AX2-CQ256-KITTOP and SK-AX2-CQ256-KITBTM	For prototyping RTAX2000S/L-CQ256 or AX2000-CQ256 using the AX2000-FG896 package

Figure 1 shows the CQ352 to FG896 complete assembly kit. SK-A1-AX2-KITTOP contains a socket LID (3), interposer (4), and eight screws (5). SK-AX1-CQ352-KITBTM contains the items: ceramic adapter (1), which is a unique adapter for AX1000, socket housing (2), and eight screws (5). SK-AX2-CQ352-KITBTM contains the following items: ceramic adapter (1), which is unique for AX2000, socket housing (2), and eight screws plus two alignment pins (5). The alignment pins are optional pins to assist in the assembly of the adapter socket.

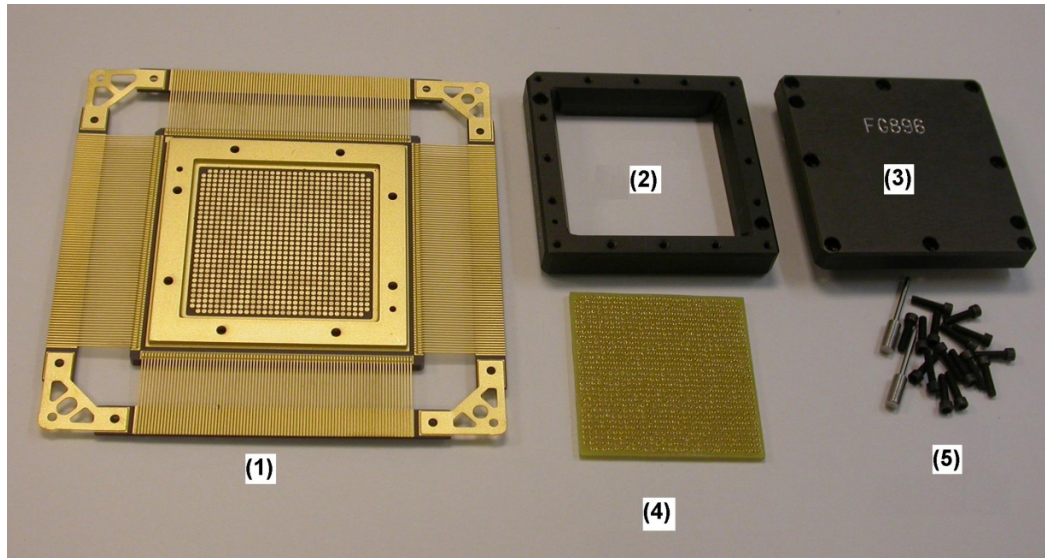

Figure 1 • Parts of CQ352 to FG896 Adapter Socket; (1) Ceramic Adapter, (2) Socket Housing, (3) Socket Lid, (4) Socket Interposer, (5) Fixing Screws and Alignment Pins

Figure 2 shows the CQ352 to FG484 complete assembly kit. SK-AX250-CQ352RTF484S contains a socket lid (3), interposer (4), and sixteen screws (5).

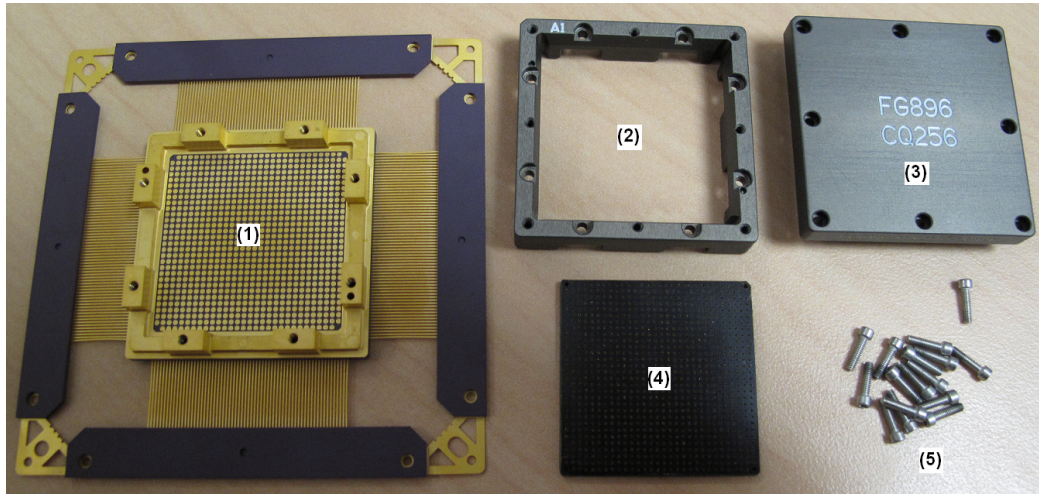

Figure 2 • Parts of CQ256 to FG896 Adapter Socket; (1) Ceramic Adapter, (2) Socket Housing, (3) Socket Lid, (4) Socket Interposer, (5) Fixing Screws

Figure 3 shows the CQ256 to FG896 complete assembly kit. SK-AX2-CQ256-KITTOP contains items socket LID (3), interposer(4), and eight screws from (5). The SK-AX2-CQ256-KITBTM contains the following items: ceramic adapter (1), which is unique for RT/AX2000, socket housing (2), and eight screws from (5).

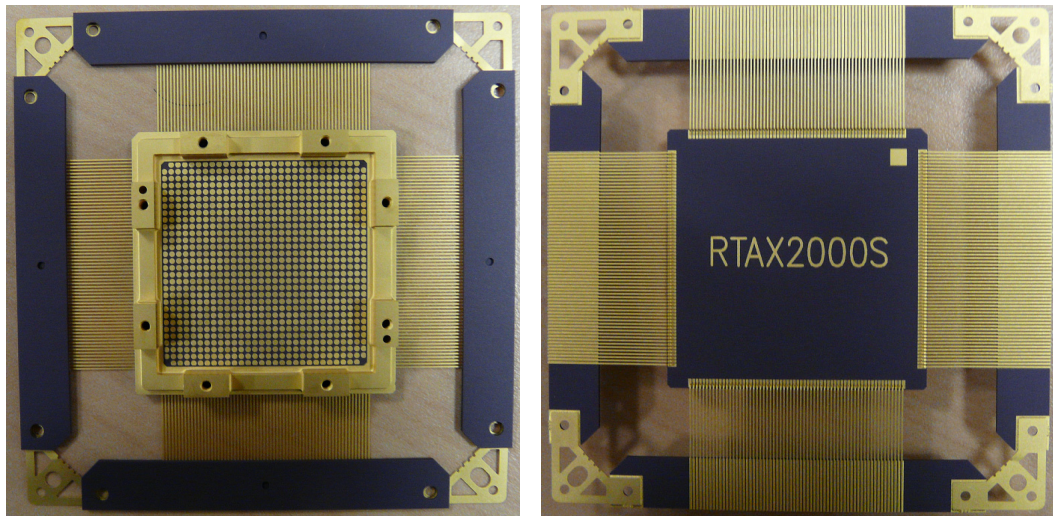

Figure 3 • RTAX2000S CQ256 to FG896 Ceramic Adapter, Top View and Bottom View and Orientation Drawings

Figure 4 shows the top view, and bottom view, and orientation view of the RTAX2000S CQ352 to FG896 adapter.

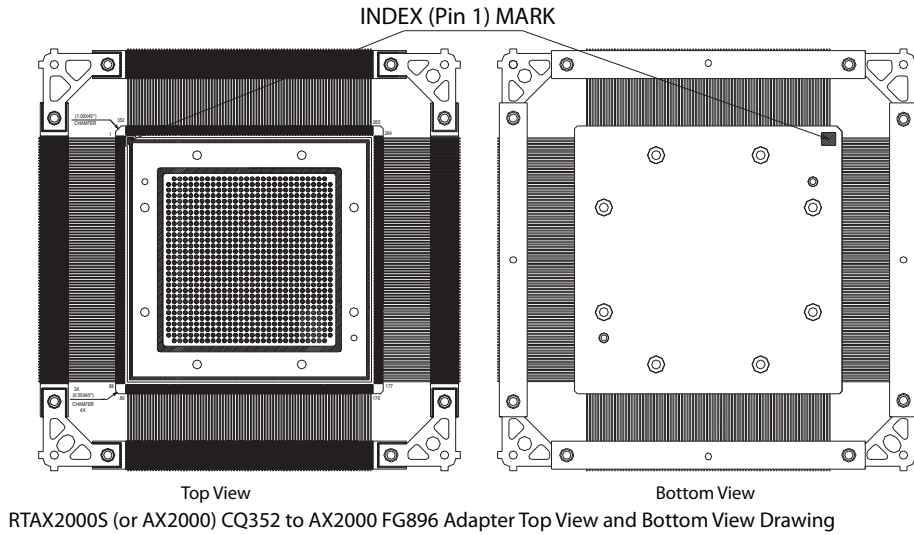

Figure 4 • RTAX2000S CQ352 to FG896 Adapter Top View, Bottom View and Orientation Drawing

Figure 5 shows the top view, bottom view, and orientation view of the RTAX1000S CQ352 to FG896 adapter.

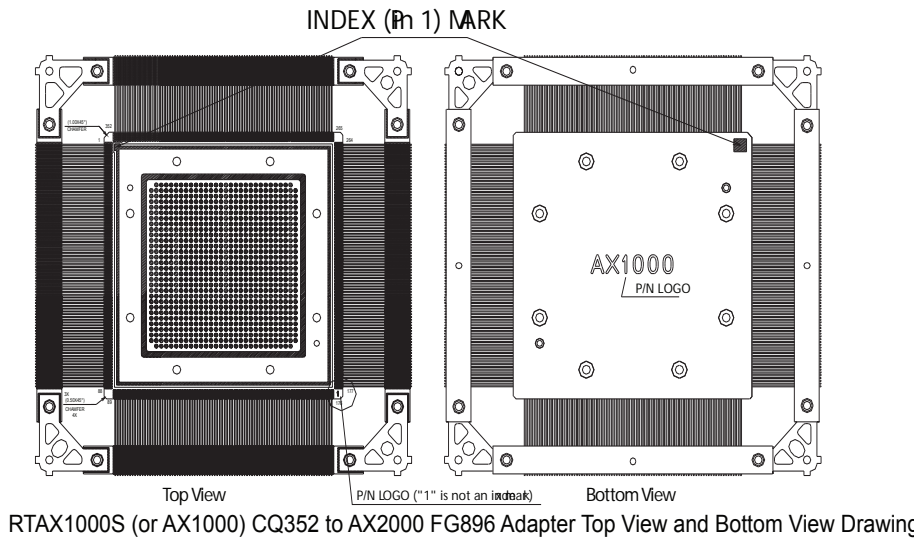
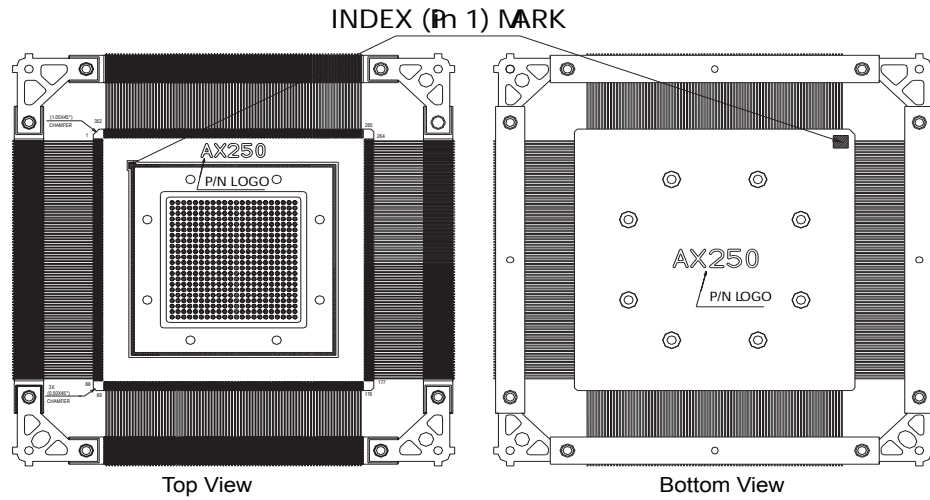

Figure 5 • RTAX1000S CQ352 to FG896 Adapter Top View, Bottom View and Orientation Drawing

Figure 6 shows the top view, bottom view, and orientation view of the RTAX250S CQ352 to FG484 23x23 adapter.



RTAX250S (or AX250) CQ352 to AX250 FG896 Adapter Top View and Bottom View Drawing

Figure 6 • RTAX250S CQ352 to FG484 Adapter Top View, Bottom View and Orientation Drawing

Figure 7 shows the top view, bottom view, and orientation view of the RTAX2000S CQ256 to FG896 adapter.

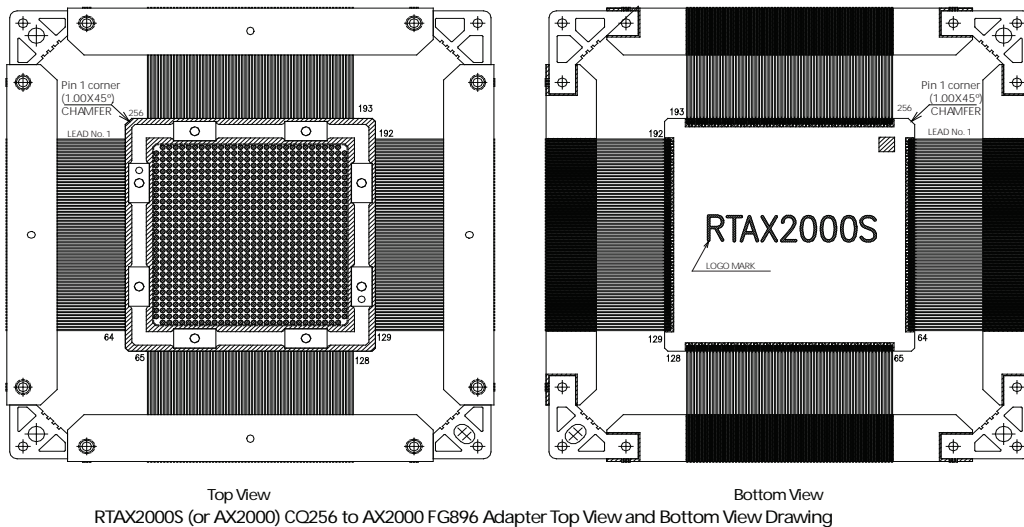

RTAX2000S (or AX2000) CQ256 to AX2000 FG896 Adapter Top View and Bottom View Drawing

Figure 7 • RTAX2000S CQ256 to FG896 Adapter Ceramic Adapter Top View and Bottom View

CQFP to FBGA Adapter Socket Assembly Procedure

Step 1

Trim and Form the CQFP Ceramic Adapter.

Notes:

1. Do NOT solder adapter to the circuit board until housing has been attached, as detailed in step 2 below.
2. The shape of the CQ256 to FG896 adapter leads after trim and form is different from those of the CQ352 to FG896 adapter and CQ352 to FG484 23x23. Refer to [Figure 8](#).

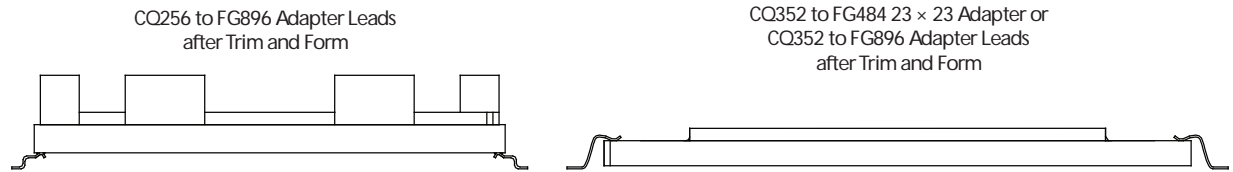

Figure 8 • CQ256 to FG896 Adapter Leads vs. CQ352 to FG896 Adapter or CQ352 to FG484 23x23 Adapter Leads after Trim and Form

[Figure 9](#) shows CQ352 to FG896 adapter trim and form.

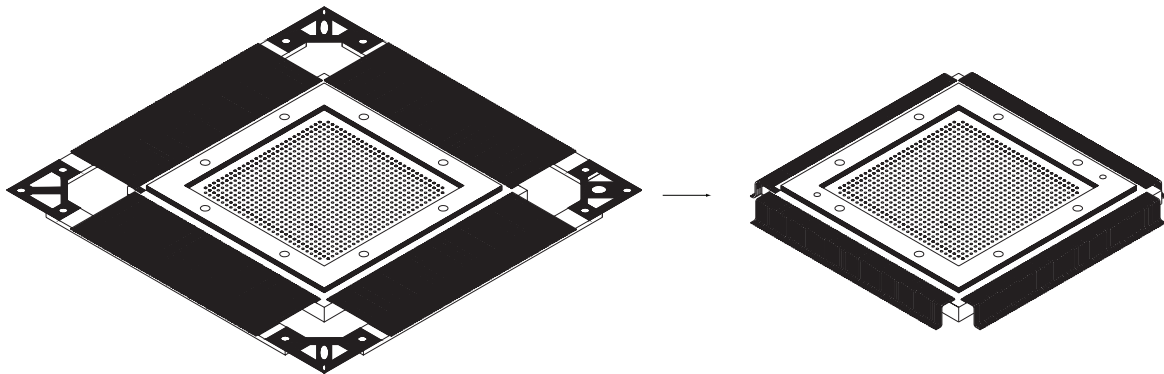

Figure 9 • CQ352 to FG896 Adapter View of Before and After Trimmed and Formed

[Figure 10](#) and [Figure 11](#) on page 7 show CQ256 to FG896 adapter trim and form.

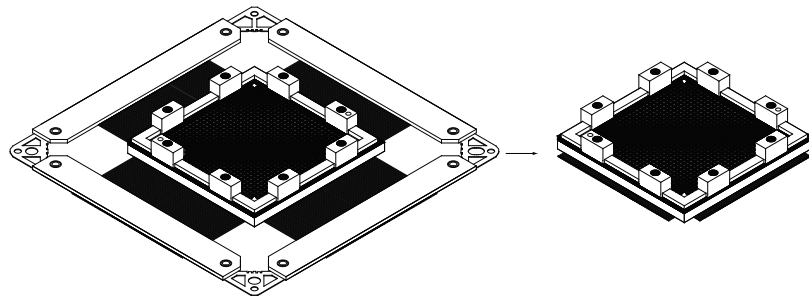

Figure 10 • CQ256 to FG896 Adapter View of Before and After Trimmed and Formed

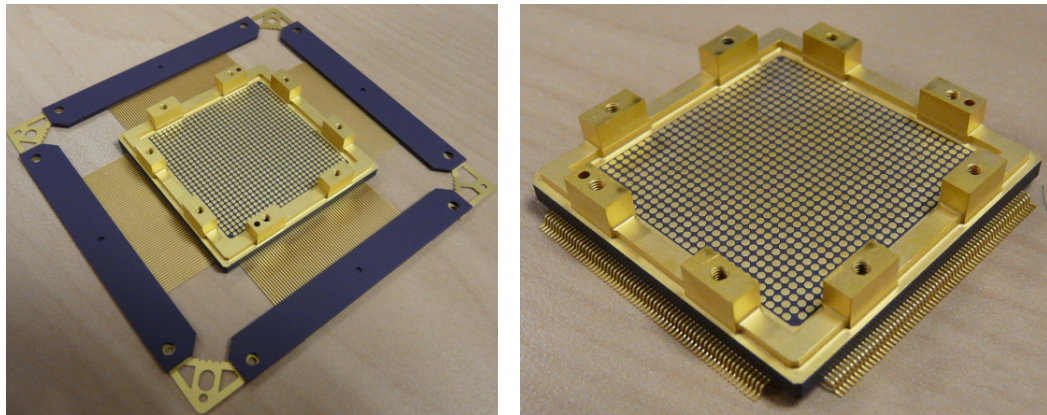

Figure 11 • CQ256 to FG896 Adapter View of Before and After Trimmed and Formed (photo)

Step 2

Assemble Socket Housing to Adapter (Torque Limit Screw Driver Not Required)

For the CQ352 to FG896 adapter, turn the ceramic adapter and socket housing upside down (Figure 12).

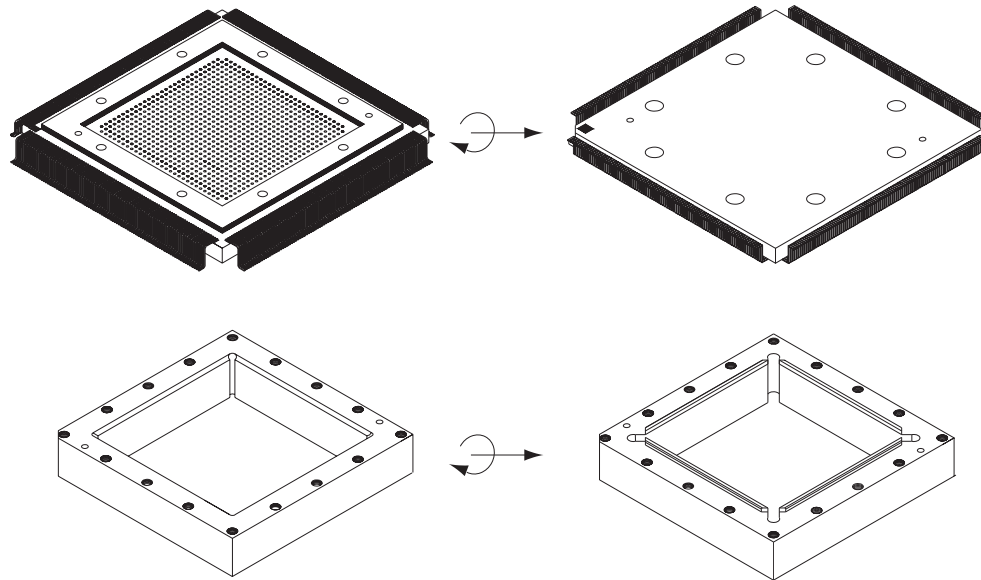

Figure 12 • Upside Down View of CQ352 to FG896 Ceramic Adapter and Socket Housing

Align the adapter A1 corner to the socket housing notch corner, and fasten the ceramic adapter to the socket housing with the eight screws provided (Figure 13).

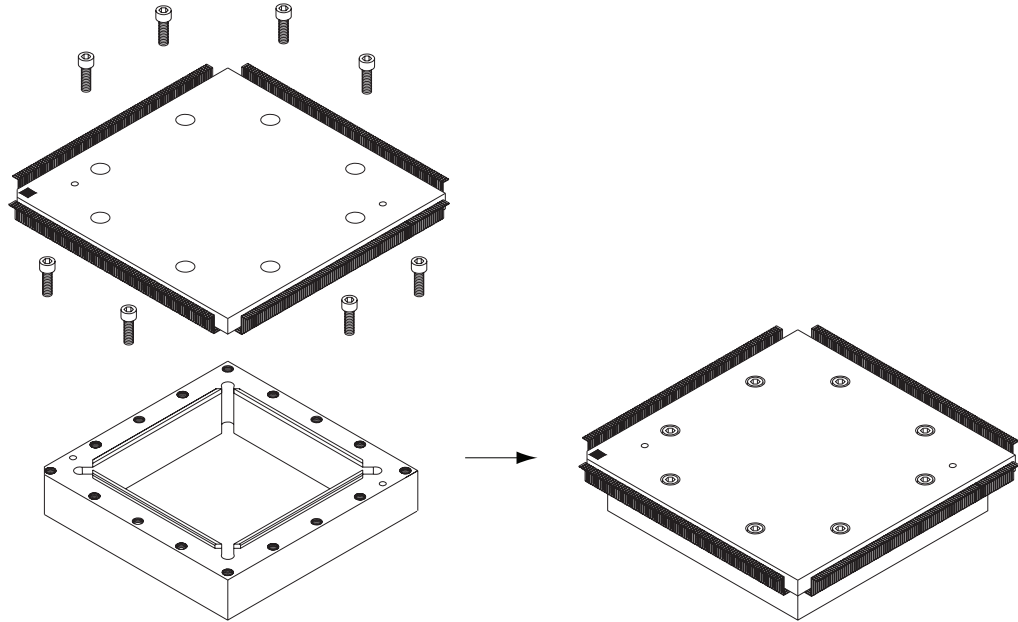

Figure 13 • Illustration of Joining the CQ352 to FG896 Adapter to the Socket Housing

Turn the assembly adapter over (Figure 14).

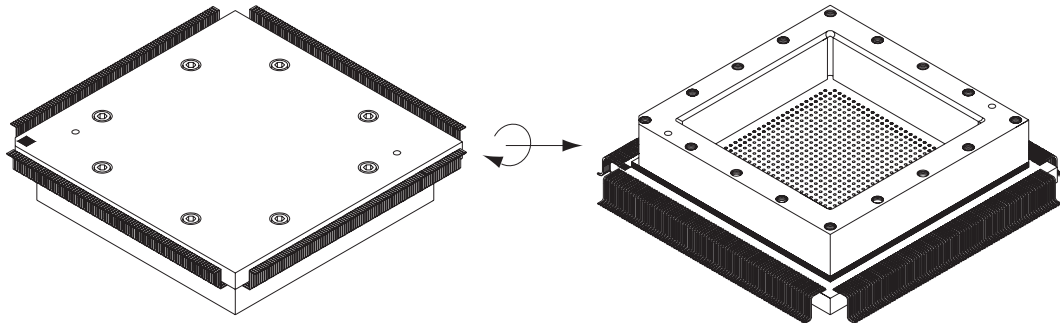

Figure 14 • View of Assembled CQ352 to FG896 Adapter Socket with Socket Housing

Note: The housing, eight screws, two alignment pins (usage is optional) plus the ceramic adapter form the KITBTM assembly.

For the CQ256 to FG896 adapter, step 2 is to assemble the socket housing on the ceramic adapter. Refer to [Figure 15](#).

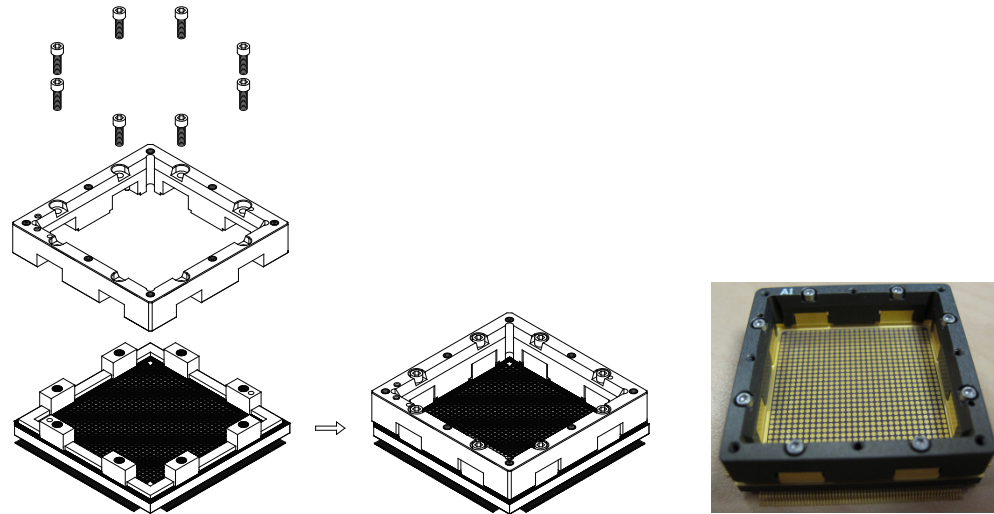

Figure 15 • View of Assembled CQ256 to FG896 Adapter with Socket Housing

Step 3

Reflow the Adapter to the PCB ([Figure 16](#)).

Note: Since reflow profiles depend heavily upon the size of the board and its components, perform reflow process optimization for better results.

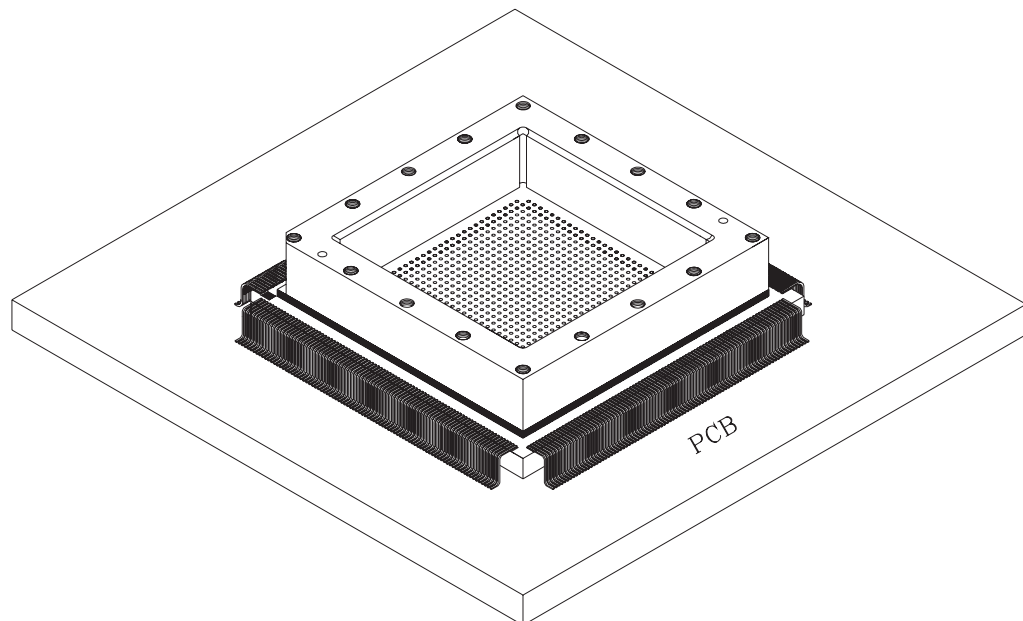

Figure 16 • Reflow the Adapter to PCB

Step 4

Place the Socket Interposer into the Adapter.

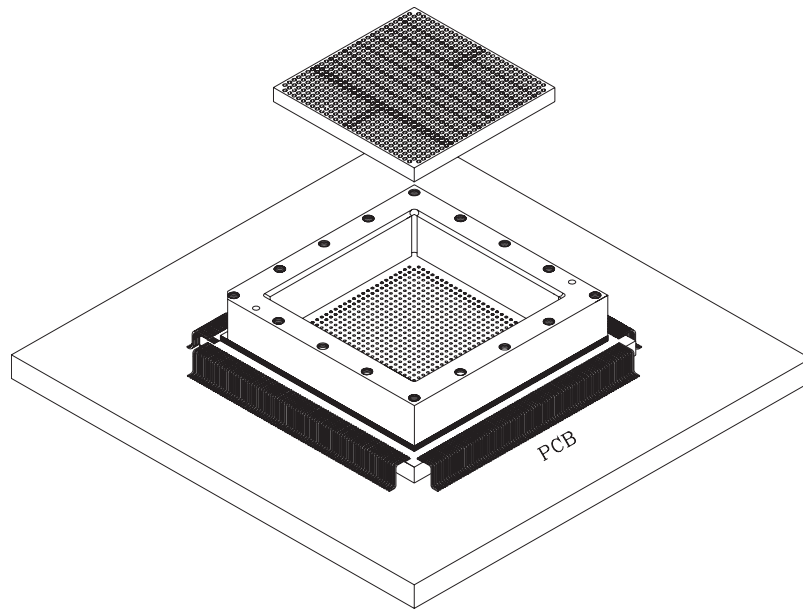

Figure 17 • Place the Socket Interposer into Adapter Assembly

Step 5

Place the FBGA Package into the Adapter.

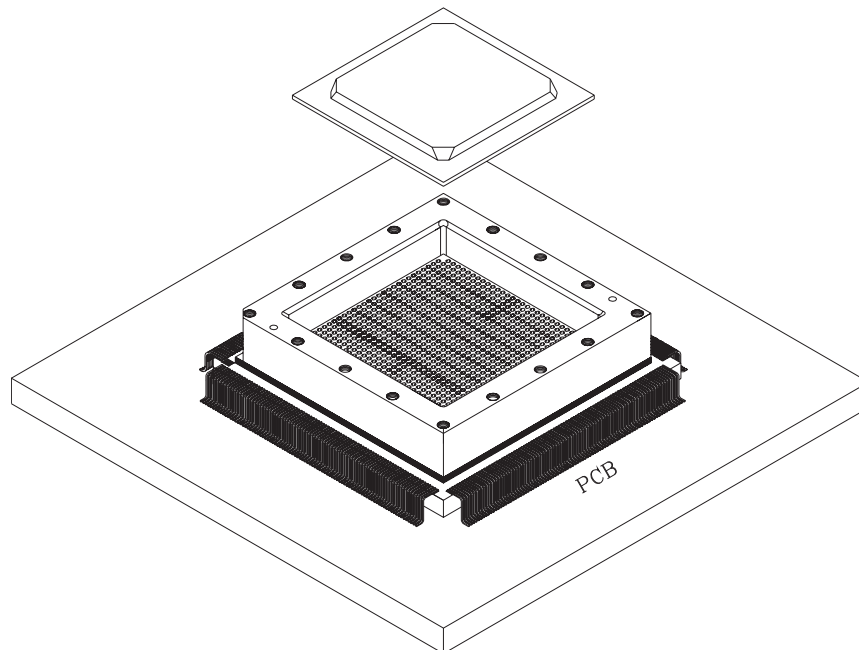

Figure 18 • Place FBGA Package into Adapter Assembly

Step 6

Place and tighten the socket lid on the socket housing with the remaining eight screws. A torque limit screw driver is not required.

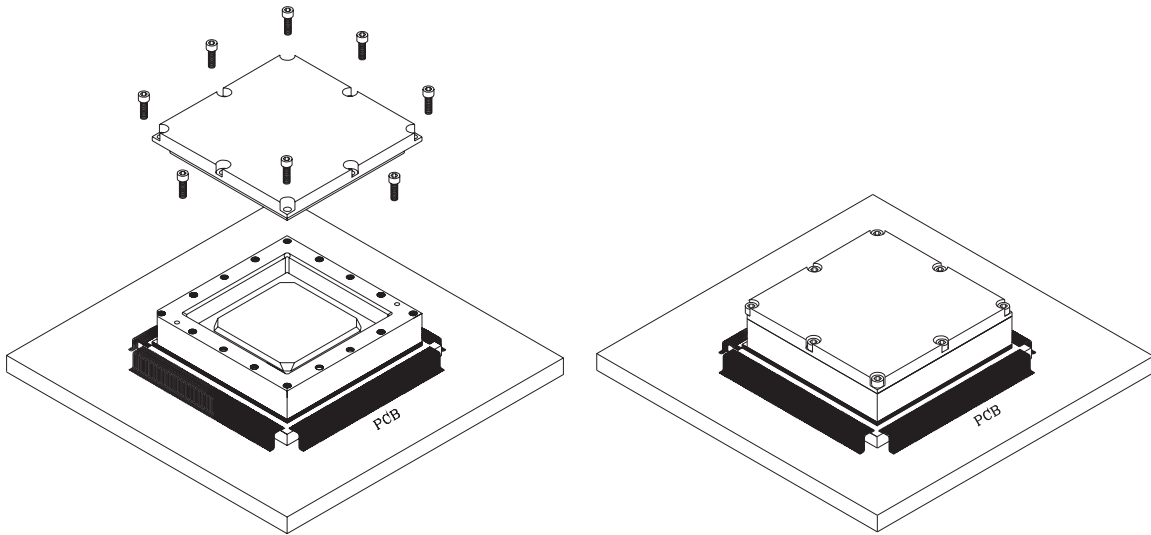

Figure 19 • Place and Tighten Socket Lid Using Eight Screws and Optional Alignment Pins

CQ352 to FG484 23x23 Adapter Socket Outline Drawing

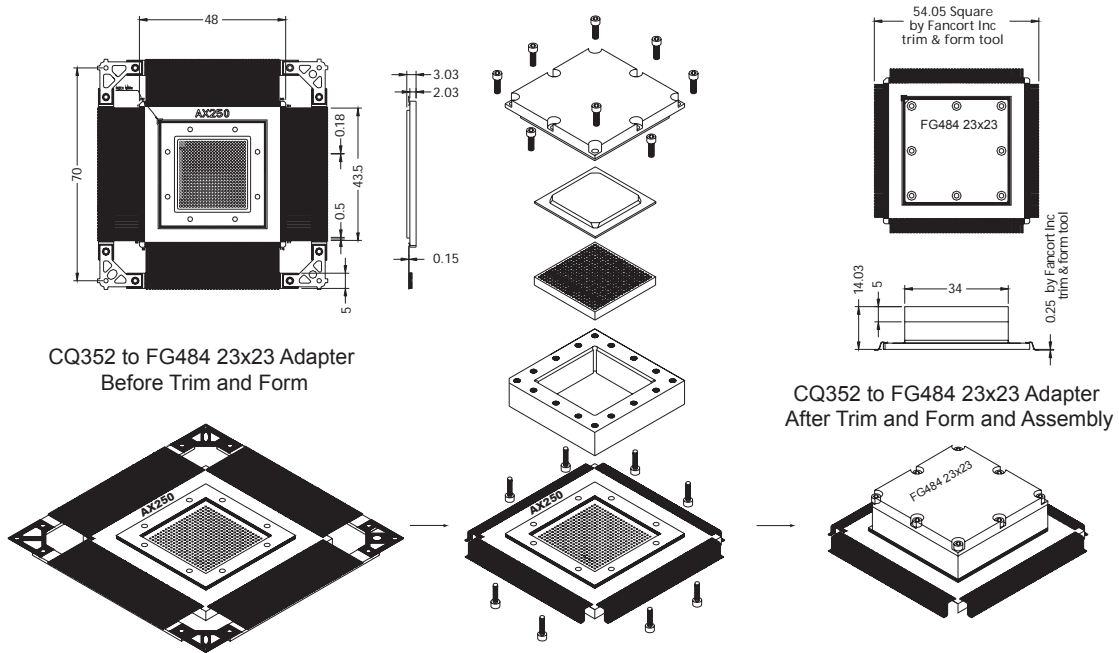

Figure 20 • CQ352 to FG484 (23x23) Adapter Socket Outline Drawing (unit: mm)

CQ352 to FG896 Adapter Socket Outline Drawing

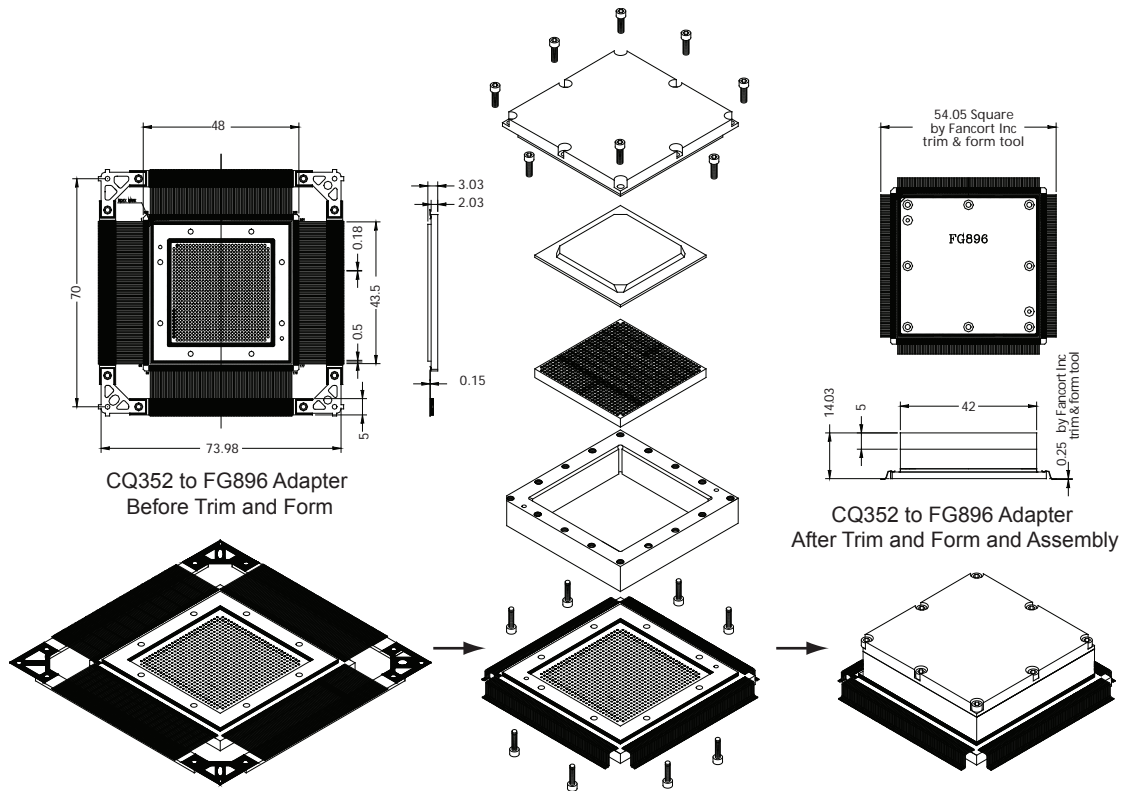

Figure 21 • CQ352 to FG896 Adapter Socket Outline Drawing (unit: mm)

CQ256 to FG896 Adapter Socket Outline Drawing

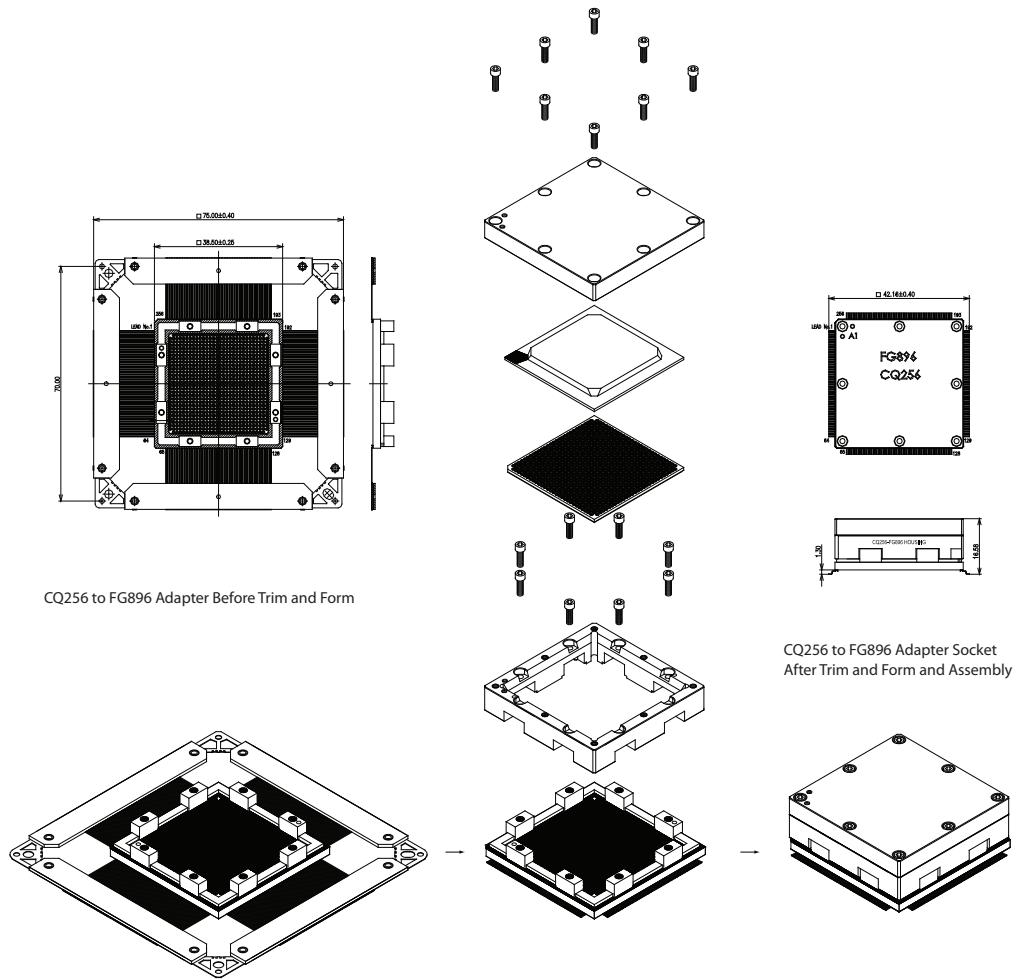

Figure 22 • CQ256 to FG896 Adapter Socket Outline Drawing (unit: mm)

CQ352 to FG896 Adapter Socket Alignment Pins

There are two optional alignment pins with the CQ352 to FG896 adapter for aligning the socket housing to the adapter. The same pins can be used to align the assembled adapter socket to the PCB. Alignment holes on the PCB are optional. Customers must decide whether or not to have alignment holes on a board.

Reflow Profile

Since the reflow profile depends upon the size of the board and other components, you need to perform additional fine tuning from the general profile shown in [Figure 23](#).

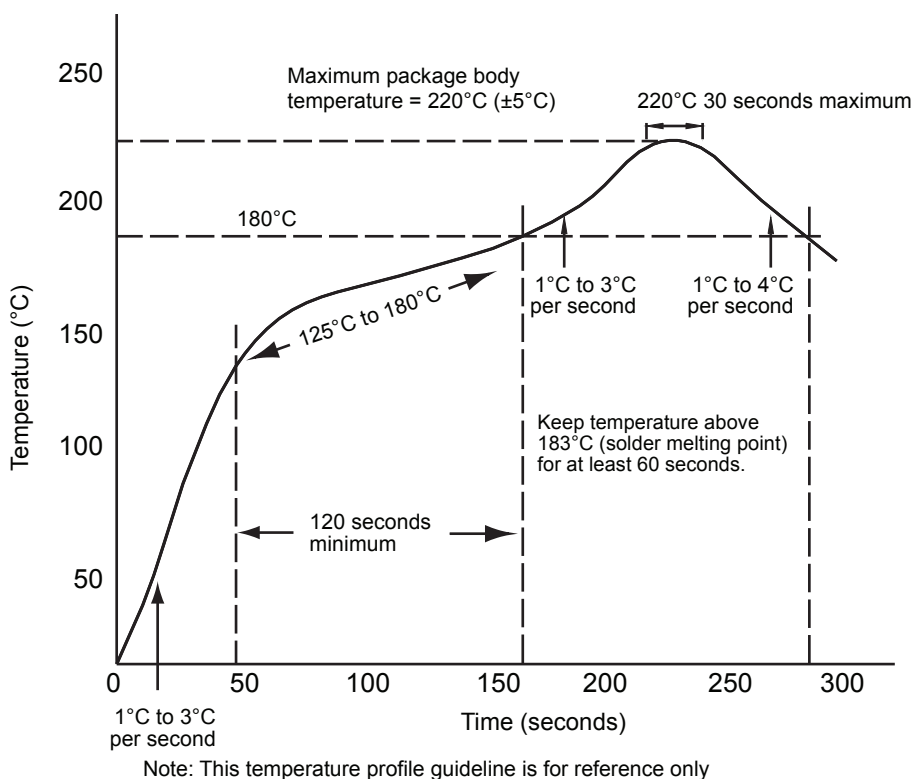

Figure 23 • Sample Temperature Profile for I/R or Convection Reflow

Interposer Insertion Limitations

The prototyping adapter sockets are designed to enable the validation and functional testing of the user FPGA designs on commercial devices before programming the design on the intended hermetic units. The interposer is typically used for a limited number of insertions (no more than 25 insertions) per user design/application. Additionally, the interposer is not intended for long term compression of the commercial prototype unit. The maximum duration for which the interposer should remain compressed is 10 days per insertion. The prototyping adapter sockets can only withstand the temperature range of -25°C to +125°C. In the event that the socket is used in ways that exceed the intended use model (examples are temperatures exceeding 125°C, high current, long mating duration exceeding 10 days, or a combination of all), there is a possibility of interposer damage or dislodging pins from the interposer, as shown in [Figure 24 on page 15](#).

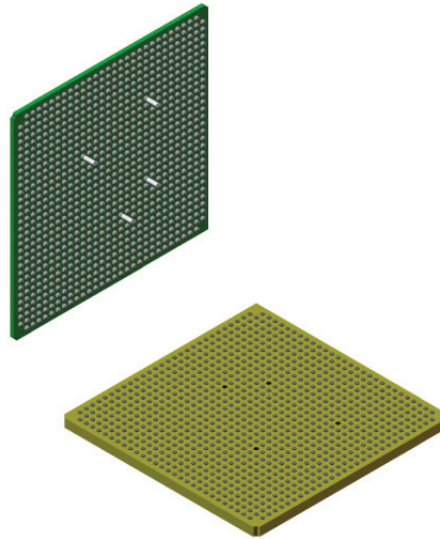

Figure 24 • Pin Dislodged from Interposer

Possible solutions for interposers with dislodged pins are listed below:

For five or fewer dislodged pins, fix them by putting the dislodged pins back into the interposer using tweezers.

Otherwise a damaged interposer should be replaced with a new interposer.

Lastly, when replacing a damaged interposer, note that the specific interposer for the prototyping adapter socket must be used. The interposer for the CQ352 to FG484 socket is different from the interposer used with the CQ352 to FG896 socket and also different from the interposer used with the CQ256 to FG896 socket.

High Frequency Signals

The adapter socket was built for functional prototyping only. It was not the intended to support at-speed testing, especially for high frequency signals such as LVDS. There is no specific series or parallel termination on the adapter board itself. To operate high frequency signals with the adapter socket, the series and parallel termination should be placed close to the I/O pins. The only possible location is on the main board, which is too distant from I/O pins and will also add significantly to the parasitic. If you need to implement LVDS or higher frequency signals, you must build a standalone board.

CQFP to FBGA Adapter Pin Mapping List

The CQFP to FBGA adapter is routed from the FBGA package to match the existing die pad available for the CQFP device being prototyped. [Table 2](#) includes information on where to download the pin mapping lists.

Table 2 • CQFP to FBGA Adapter Pin Mapping List

Adapter Socket	Ordering Part Number	Prototyped and Prototype Device	Adapter Pin Mapping List Document #
CQ352 to FG484 23x23	SK-AX250-CQ352RTFG484S	For prototyping RTAX250S/L-CQ352 or AX250-CQ352 using the AX250-FG484 package	Refer to the Prototyping Solutions section of the Microsemi SoC Products Group website: www.microsemi.com/soc/techdocs/package/default.aspx .
CQ352 to FG896	SK-AX1-AX2-KITTOP and SK-AX1-CQ352-KITBTM	For prototyping RTAX1000S/L-CQ352 or AX1000-CQ352 using the AX1000-FG896 package	
CQ352 to FG896	SK-AX1-AX2-KITTOP and SK-AX2-CQ352-KITBTM	For prototyping RTAX2000S/L-CQ352 or AX2000-CQ352 using the AX2000-FG896 package	

Prototyped Product, Adapter, and PCB Design Matrix

Designing the PCB for a specific product requires an understanding of which adapter socket will work. Each adapter socket is routed differently. The design is based on the Axcelerator device or its RadTolerant equivalent derivative being prototyped and the commercial Axcelerator FG package used for prototyping. [Table 3](#) shows the combinations that will work.

Table 3 • Prototyping Design Matrix

Prototyped Product	Adapter Part Number	Prototype Vehicle	PCB Design
AX250-CQ352	SK-AX250-CQ352RTFG484S	AX250-FG484 23x23	AX250-CQ352
AX1000-CQ352	SK-AX1-AX2-KITTOP and SK-AX1-CQ352-KITBTM	AX1000-FG896	AX1000-CQ352
AX2000-CQ352	SK-AX1-AX2-KITTOP and SK-AX2-CQ352-KITBTM	AX2000-FG896	AX2000-CQ352
RTAX250S-CQ352, RTAX250SL-CQ352	SK-AX250-CQ352RTFG484S	AX250-FG484 23x23	AX250-CQ352 ¹

Notes:

- The PCB designer should consider the eight pin pairs of the phase-locked loop (PLL) analog power supply (VCCPLA/VCOMPLA, VCCPLB/VCOMPLB, VCCPLC/VCOMPLC, VCCPLD/VCOMPLD, VCCPLE/VCOMPLE, VCCPLF/VCOMPLF, VCCPLG/VCOMPLG, and VCCPLH/VCOMPLH). They should be treated as follows:
 - VCCPLA/B/C/D/E/F/G/H —There are eight in each device. VCCPLA supports the PLL associated with global resource HCLKA, and VCCPLB supports the PLL associated with global resource HCLKB. These PLL analog power supply pins should be connected to 1.5 V whether or not the PLL is used. Refer to the [Axcelerator Family FPGAs and RTAX-S/SL and RTAX-DSP Radiation-Tolerant FPGAs datasheets](#) for pin assignment information.
 - VCOMPLA/B/C/D/E/F/G/H —These are compensation reference signals for the internal PLL. There are eight in each device. VCOMPLA supports the PLL associated with global resource HCLKA, and VCOMPLE supports the PLL associated with global resource HCLKE. The VCOMPLX pins should be left floating if the PLL is not being used. Refer to the [Axcelerator Family FPGAs and RTAX-S/SL and RTAX-DSP Radiation-Tolerant FPGAs datasheets](#) for pin assignment information.
- Since the Axcelerator and RTAX-S/L devices are exactly pin-compatible except for the PLL, which RTAX-S/L does not have, designing the PCB with VCCPL(X) pins connected to 1.5 V will not affect the function of the RTAX-S/L devices. Pins for VCOMPL(X) can be designed with land patterns only. These 16 PLL pins are not connected internally inside the RTAX-S packages.

Table 3 • Prototyping Design Matrix (continued)

Prototyped Product	Adapter Part Number	Prototype Vehicle	PCB Design
RTAX1000S-CQ352, RTAX1000SL-CQ352	SK-AX1-AX2-KITTOP and SK-AX1-CQ352-KITBTM	AX1000-FG896	AX1000-CQ352 ¹
RTAX2000S-CQ352, RTAX2000SL-CQ352	SK-AX1-AX2-KITTOP and SK-AX2-CQ352-KITBTM	AX2000-FG896	AX2000-CQ352 ¹
RTAX250S-CQ352, RTAX250SL-CQ352	SK-AX250-CQ352RTFG484S	AX250-FG484 23x23	RTAX250S-CQ352, RTAX250SL-CQ352 ^{1, 2}
RTAX1000S-CQ352, RTAX1000SL-CQ352	SK-AX1-AX2-KITTOP and SK-AX1-CQ352-KITBTM	AX1000-FG896	RTAX1000S-CQ352, RTAX1000SL-CQ352 ^{1, 2}
RTAX2000S-CQ352, RTAX2000SL-CQ352	SK-AX1-AX2-KITTOP and SK-AX2-CQ352-KITBTM	AX2000-FG896	RTAX2000S-CQ352, RTAX2000SL-CQ352 ^{1, 2}

Notes:

- The PCB designer should consider the eight pin pairs of the phase-locked loop (PLL) analog power supply (VCCPLA/VCOMPLA, VCCPLB/VCOMPLB, VCCPLC/VCOMPLC, VCCPLD/VCOMPLD, VCCPLE/VCOMPLE, VCCPLF/VCOMPLF, VCCPLG/VCOMPLG, and VCCPLH/VCOMPLH). They should be treated as follows:
 - VCCPLA/B/C/D/E/F/G/H —There are eight in each device. VCCPLA supports the PLL associated with global resource HCLKA, and VCCPLB supports the PLL associated with global resource HCLKB. These PLL analog power supply pins should be connected to 1.5 V whether or not the PLL is used. Refer to the [Axcelerator Family FPGAs](#) and [RTAX-S/SL and RTAX-DSP Radiation-Tolerant FPGAs](#) datasheets for pin assignment information.
 - VCOMPLA/B/C/D/E/F/G/H —These are compensation reference signals for the internal PLL. There are eight in each device. VCOMPLA supports the PLL associated with global resource HCLKA, and VCOMPLE supports the PLL associated with global resource HCLKE. The VCOMPLX pins should be left floating if the PLL is not being used. Refer to the [Axcelerator Family FPGAs](#) and [RTAX-S/SL and RTAX-DSP Radiation-Tolerant FPGAs](#) datasheets for pin assignment information.
- Since the Axcelerator and RTAX-S/L devices are exactly pin-compatible except for the PLL, which RTAX-S/L does not have, designing the PCB with VCCPL(X) pins connected to 1.5 V will not affect the function of the RTAX-S/L devices. Pins for VCOMPL(X) can be designed with land patterns only. These 16 PLL pins are not connected internally inside the RTAX-S packages.

List of Changes

The following table lists critical changes that were made in the current version of the chapter.

Revision*	Changes	Page
Revision 4 (November 2011)	A note was added to the "Introduction" section, clarifying that the CQFP to FBGA adapter sockets are intended for functional prototyping, not at-speed prototyping (SAR 33471).	1
	In Table 1, last row, the part number of the KITTOP was changed from SH-AX2-CQ256-KITTOP to SK-AX2-CQ256-KITTOP (SAR 29920).	2
	In Table 1, third row and third column, the description for CQ256 to FG896 prototyping adapter has been changed from "For prototyping RTAX2000S/L-CQ352 or AX2000-CQ256 using the AX2000-FG896 package" to "For prototyping RTAX2000S/L-CQ256 or AX2000-CQ256 using the AX2000-FG896 package" (SAR 30009).	2
	Figure 22 · CQ256 to FG896 Adapter Socket Outline Drawing (unit: mm) was improved in resolution to make the dimensions legible (SAR 25336).	13
	The "Interposer Insertion Limitations" section is new (SAR 32813).	14
	The "High Frequency Signals" section is new (SAR 30885).	15
	The part numbers in Table 2 · CQFP to FBGA Adapter Pin Mapping List and Table 3 · Prototyping Design Matrix were inadvertently reverted to obsolete part numbers in revision 4 of this document. This has been corrected and the correct, current part numbers have been restored (SAR 29920).	16
Revision 3 (August 2008)	The CQ256 to FG896 adapter was added, including instructions, drawings, photographs, and table entries throughout the document.	N/A
Revision 2	All tables were updated to include current part numbers for ordering.	N/A
	A note was added to "Step 1" to caution against soldering.	6
	"Step 3" was expanded.	9
	The Related Documents section was revised to add mechanical drawings and update the URL for the pin mapping lists.	18

*Note: *The revision number is located in the part number after the hyphen. The part number is displayed at the bottom of the last page of the document. The digits following the slash indicate the month and year of publication.*



Microsemi Corporate Headquarters
One Enterprise, Aliso Viejo CA 92656 USA
Within the USA: +1 (949) 380-6100
Sales: +1 (949) 380-6136
Fax: +1 (949) 215-4996

Microsemi Corporation (NASDAQ: MSCC) offers a comprehensive portfolio of semiconductor solutions for: aerospace, defense and security; enterprise and communications; and industrial and alternative energy markets. Products include high-performance, high-reliability analog and RF devices, mixed signal and RF integrated circuits, customizable SoCs, FPGAs, and complete subsystems. Microsemi is headquartered in Aliso Viejo, Calif. Learn more at www.microsemi.com.

© 2012 Microsemi Corporation. All rights reserved. Microsemi and the Microsemi logo are trademarks of Microsemi Corporation. All other trademarks and service marks are the property of their respective owners.

X-ON Electronics

Largest Supplier of Electrical and Electronic Components

Click to view similar products for [Sockets & Adapters](#) category:

Click to view products by [Microsemi](#) manufacturer:

Other Similar products are found below :

[6508-0-00-01-00-00-33-0](#) [AC164341](#) [AC164348](#) [1262](#) [22827](#) [AC164353](#) [TDGL015](#) [SA247](#) [SM64TQ-ACTEL-1](#) [70-0036](#) [DS91230+](#)
[SMPA-ISP-ACTEL-3-KIT](#) [16017](#) [KIT 70601-3](#) [SM132CQ-ACTEL](#) [IPC0181](#) [IPC0175](#) [IPC0165](#) [AC164397](#) [conga-Thin MITX/eDP to DP](#)
[Adapter](#) [ML-ADP-EVN](#) [ASA.01](#) [ASA.09](#) [ASA.12](#) [ASA.14](#) [TOOLSTICK990MPP](#) [MIKROE-425](#) [C305000ACP2](#) [110-83-320-41-605101](#)
[110-83-632-41-605101](#) [110-83-640-41-605101](#) [110-83-628-41-605101](#) [116-83-306-41-001101](#) [PA0003](#) [PA0007](#) [PA0009](#) [PA0035](#) [PA0085](#)
[PA0096](#) [IPC0079](#) [ATARD-DBGADPT](#) [80-000286](#) [ATSTK600-RC88](#) [ATSTK600-SC06](#) [ATSTK600-RC78](#) [SPC560PADPT64S](#) [AC164345](#)
[AC164342](#) [14-351000-11-RC](#) [966927-1](#)