

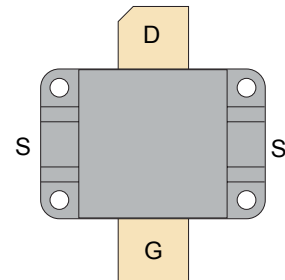

RF POWER VERTICAL MOSFET

The VRF154FL is a gold-metallized silicon n-channel RF power transistor designed for broadband commercial and military applications requiring high power and gain without compromising reliability, ruggedness, or inter-modulation distortion.



FEATURES

- Improved Ruggedness $V_{(BR)DSS} = 170V$
- Designed for 2 - 100MHz Operation
- 600W with 17dB Typical Gain @ 30MHz, 50V
- Excellent Stability & Low IMD
- Common Source Configuration
- Available in Matched Pairs
- 70:1 Load VSWR Capability at Specified Operating Conditions
- Nitride Passivated
- Economical Flangeless Package
- Refractory Gold Metallization
- High Voltage Replacement for MRF154
- RoHS Compliant 

Maximum Ratings

 All Ratings: $T_c = 25^\circ C$ unless otherwise specified

Symbol	Parameter	VRF154FL(MP)	Unit
V_{DSS}	Drain-Source Voltage	170	V
I_D	Continuous Drain Current @ $T_c = 25^\circ C$	60	A
V_{GS}	Gate-Source Voltage	± 40	V
P_D	Total Device dissipation @ $T_c = 25^\circ C$	1350	W
T_{STG}	Storage Temperature Range	-65 to 150	°C
T_J	Operating Junction Temperature Max	200	

Static Electrical Characteristics

Symbol	Parameter	Min	Typ	Max	Unit
$V_{(BR)DSS}$	Drain-Source Breakdown Voltage ($V_{GS} = 0V, I_D = 100mA$)	170	180		V
$V_{DS(ON)}$	On State Drain Voltage ($I_{D(ON)} = 40A, V_{GS} = 10V$)		3.7	5.7	
I_{DSS}	Zero Gate Voltage Drain Current ($V_{DS} = 100V, V_{GS} = 0V$)			4.0	mA
I_{GSS}	Gate-Source Leakage Current ($V_{DS} = \pm 20V, V_{GS} = 0V$)			4.0	μA
g_{fs}	Forward Transconductance ($V_{DS} = 10V, I_D = 40A$)	16			mhos
$V_{GS(TH)}$	Gate Threshold Voltage ($V_{DS} = 10V, I_D = 100mA$)	2.9	3.6	4.4	V

Thermal Characteristics

Symbol	Characteristic	Min	Typ	Max	Unit
$R_{\theta JC}$	Junction to Case Thermal Resistance			0.13	°C/W
$R_{\theta JHS}$	Junction to Sink Thermal Resistance (Use High Efficiency Thermal Joint Compound and Planar Heat Sink Surface.)		0.22		



CAUTION: These Devices are Sensitive to Electrostatic Discharge. Proper Handling Procedures Should Be Followed.

Dynamic Characteristics

VRF154FL(MP)

Symbol	Parameter	Test Conditions	Min	Typ	Max	Unit
C_{iss}	Input Capacitance	$V_{GS} = 0V$ $V_{DS} = 50V$ $f = 1MHz$		1750		pF
C_{oss}	Output Capacitance			775		
C_{rss}	Reverse Transfer Capacitance			135		

Functional Characteristics

Symbol	Parameter	Min	Typ	Max	Unit
G_{PS}	$f = 30MHz, V_{DD} = 50V, I_{DQ} = 800mA, P_{out} = 600W$		17		dB
η_D	$f = 30MHz, V_{DD} = 50V, I_{DQ} = 800mA, P_{out} = 600W_{PEP}$		45		%
IMD _(dB)	$f1 = 30MHz, f2 = 30.001MHz, V_{DD} = 50V, I_{DQ} = 800mA, P_{out} = 600W_{PEP}^1$		-25		dBc
ψ	$f = 30MHz, V_{DD} = 50V, I_{DQ} = 800mA, P_{out} = 600W$ CW 70:1 VSWR - All Phase Angles, 0.2mSec X 20% Duty Factor	No Degradation in Output Power			

1. To MIL-STD-1311 Version A, test method 2204B, Two Tone, Reference Each Tone

Microsemi reserves the right to change, without notice, the specifications and information contained herein.

Typical Performance Curves

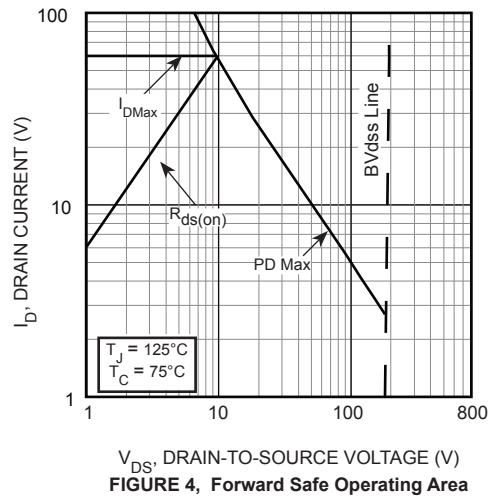
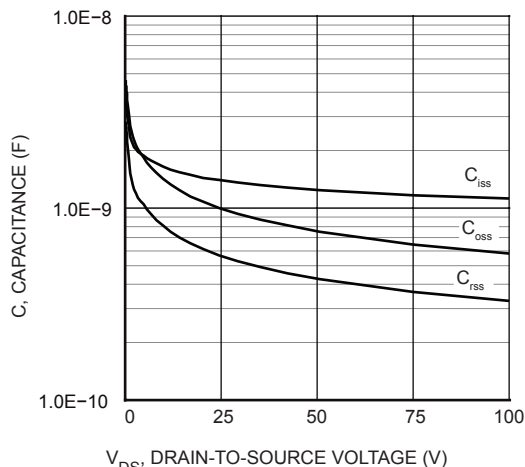
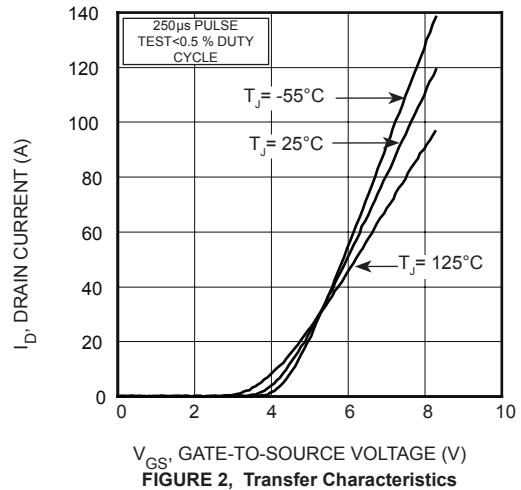
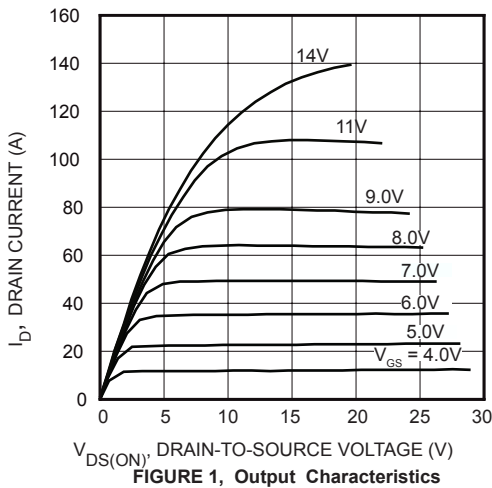

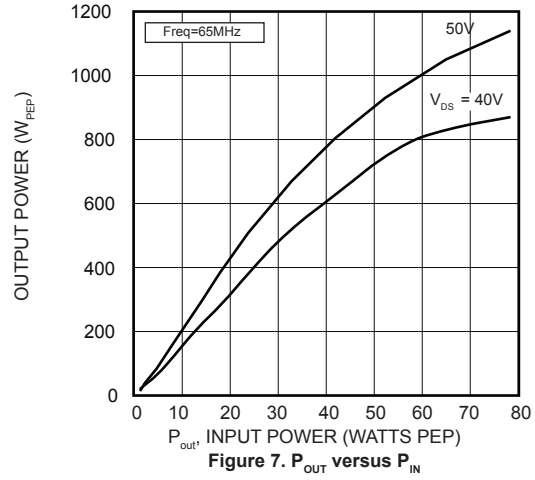
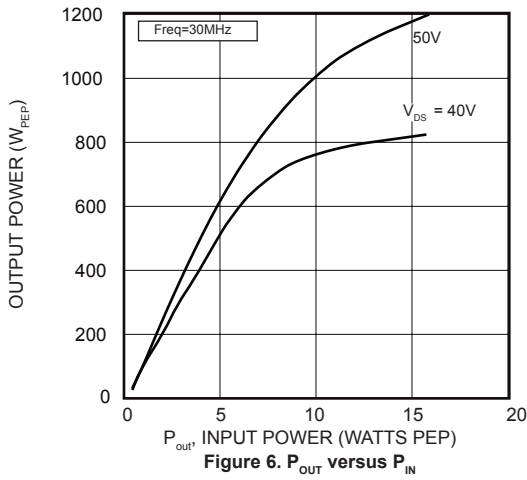
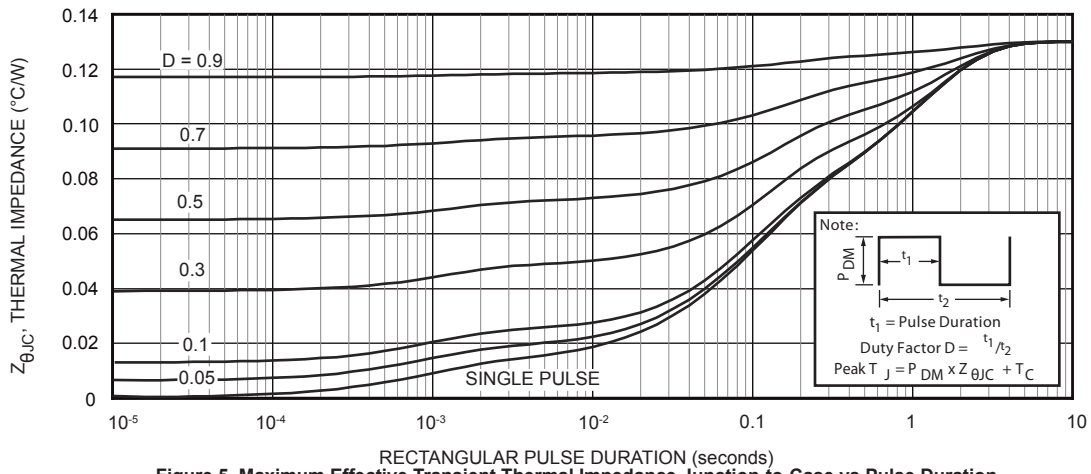

30MHz Test Circuit

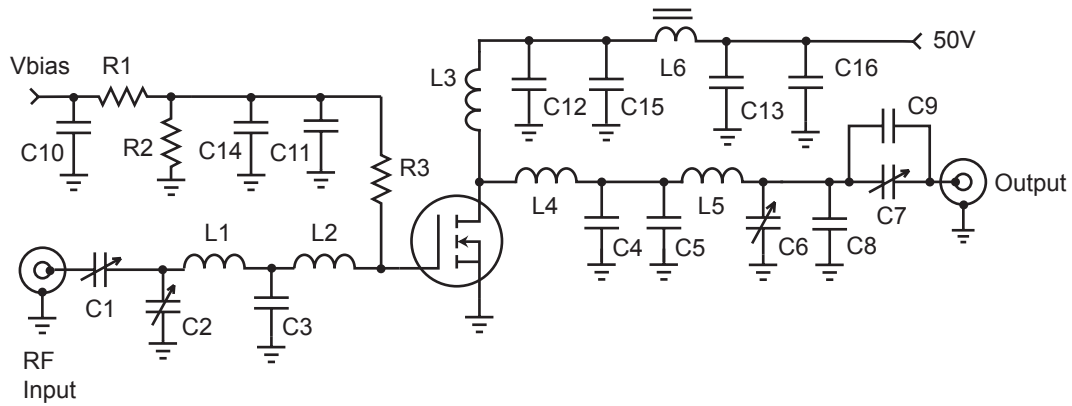

- | | |
|--------------------------------------|---------------------------------------|
| C1, C2, C6, C7 ARCO 465 mica trimmer | L1 110nH 4t #22 0.312"d .30"l |
| C3 1800pF ATC700B ceramic | L2 29nH 2t #22 .188" dia .10" l |
| C4 680pF metal clad 500V mica | L3 0.3uH - 6t #16 enam. .5" dia. |
| C5 390pF metal clad 500V mica | L4 22nH - 1t #16 enam. .375" dia. |
| C8 100pF ATC 700E ceramic | L5 117nH - 3t #16 enam. .5" dia. .3"l |
| C9 120pF ATC 700E ceramic | L6 1t #16 on 2x 267300081 .5" bead |
| C10 - C13 .01uF 100V ceramic SMT | R1-R2 1kΩ 1/4W |
| C14 - C16 .1uF 100V ceramic SMT | R3 10Ω 1/4W |

2-50MHz 1kW Wideband Amplifier

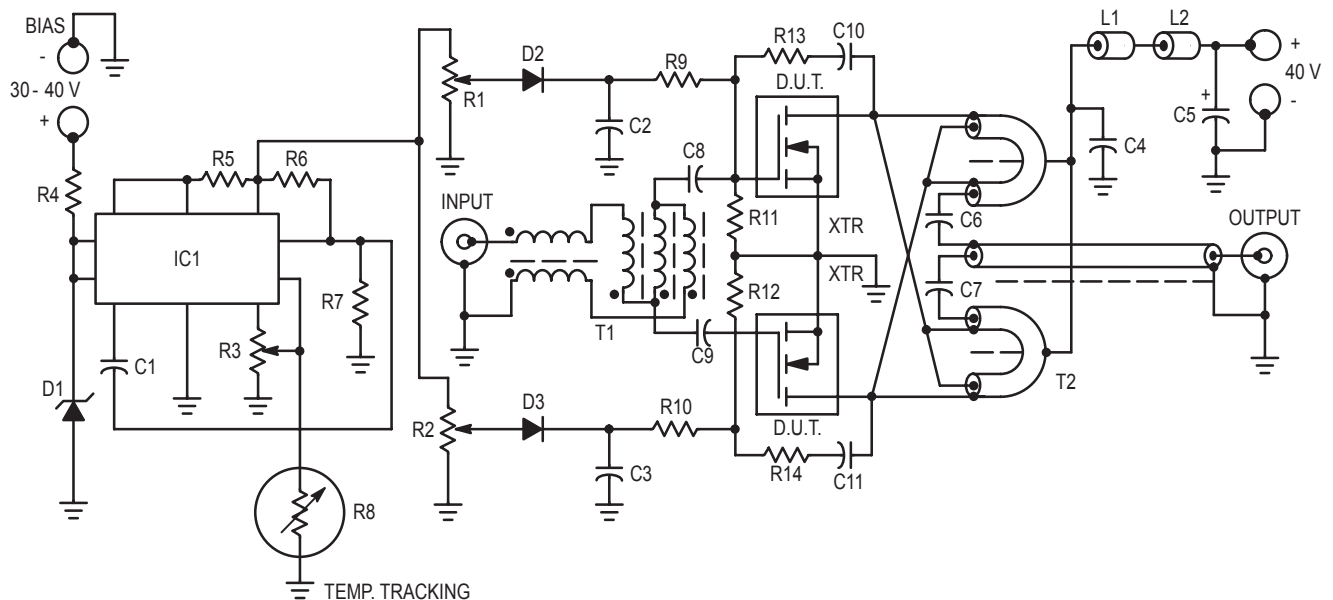

- | | |
|---|---|
| C1 - 1000pF Ceramic | R7 - 10k |
| C2, C3, C4, C8, C9, C10, C11 -0.1uF Ceramic | R8 - Thermistor, 10k (25°C), 2.5k (75°C) |
| C5 - 10uF / 100 V Electrolytic | R9, R10 - 100 Ohms |
| C6, C7 - 0.1uF Ceramic, (ATC 200/823 or Equivalent) | R11, R12 - 1.0k |
| D1 - 28V Zener, 1N5362 or Equivalent | R13, R14 - 50Ω, 2 x 100Ω 2W Carbon in Parallel |
| D3 - 1N4148 | T1 - 9:1 Transformer, Trifilar and Balun Wound on Separate Fair-Rite Products Corp. Balun Cores #286100012, 5 Turns Each. |
| IC1 - MC1723 | T2 - 1:9 Transformer Balun 50 Ohm CO-AX Cable RG-188, Low Impedance Lines W.L. Gore 16 Ohms CO-AX Type CXN 1837. Each Winding Threaded Through Two Fair-Rite Products Corp. #2661540001 Ferrite Sleeves (6 Each). |
| L1, L2 - Fair-Rite Products Corp. Ferrite Beads #2673000801 | XTR - VRF154 |
| R1, R2, R3 - 10k Trimpot | |
| R4 - 1.0 k / 1.0W | |
| R5 - 10 Ohms | |
| R6 - 2.0k | |

Adding MP at the end of P/N specifies a matched pair where $V_{GS(TH)}$ is matched between the two parts. V_{TH} values are marked on the devices per the following table.

Code	Vth Range	Code 2	Vth Range
A	2.900 - 2.975	M	3.650 - 3.725
B	2.975 - 3.050	N	3.725 - 3.800
C	3.050 - 3.125	P	3.800 - 3.875
D	3.125 - 3.200	R	3.875 - 3.950
E	3.200 - 3.275	S	3.950 - 4.025
F	3.275 - 3.350	T	4.025 - 4.100
G	3.350 - 3.425	W	4.100 - 4.175
H	3.425 - 3.500	X	4.175 - 4.250
J	3.500 - 3.575	Y	4.250 - 4.325
K	3.575 - 3.650	Z	4.325 - 4.400

V_{TH} values are based on Microsemi measurements at datasheet conditions with an accuracy of 1.0%.

Thermal Considerations and Package Mounting:

The rated 1350W power dissipation is only available when the package mounting surface is at 25°C and the junction temperature is 200 °C. The thermal resistance between junctions and case mounting surface is 0.13°C/W. When installed, an additional thermal impedance of 0.09°C/W between the package base and the mounting surface is smooth and flat. Thermal joint compound must be used to reduce the effects of small surface irregularities. The heatsink should incorporate a copper heat spreader to obtain best results.

The lid maintains the required mounting pressure while allowing for thermal expansion of both the device and the heat sink. Four 4-40 (M3) screws provide the minimum 125 lb. required mounting force. T=4-6 in-lb. Please refer to App Note 1810 "Mounting Instructions for Flangeless Packages."

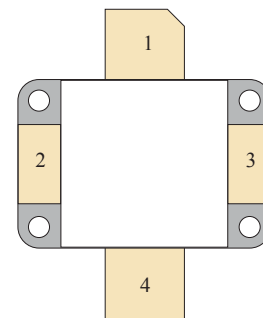
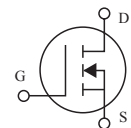
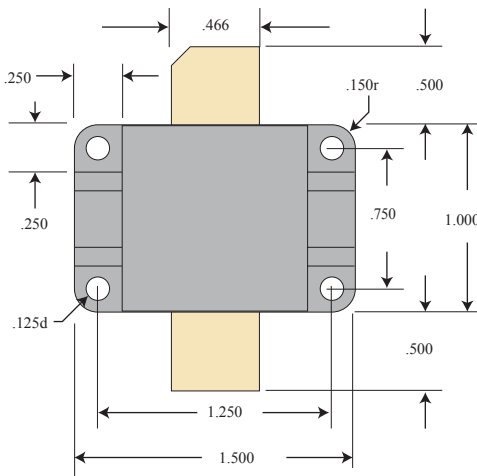

PIN 1 - DRAIN
 PIN 2 - SOURCE
 PIN 3 - SOURCE
 PIN 4 - GATE

HAZARDOUS MATERIAL WARNING

The ceramic portion of the device between leads and mounting flange is beryllium oxide. Beryllium oxide dust is highly toxic when inhaled. Care must be taken during handling and mounting to avoid damage to this area. These devices must never be thrown away with general industrial or domestic waste. BeO substrate weight: 1.934g. Percentage of total module weight which is BeO: 20%.

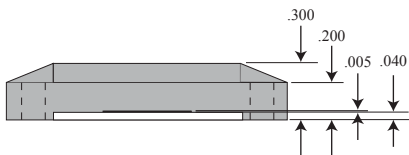



Microsemi Headquarters
One Enterprise, Aliso Viejo,
CA 92656 USA

Within the USA: +1 (800) 713-4113
Outside the USA: +1 (949) 380-6100
Sales: +1 (949) 380-6136
Fax: +1 (949) 215-4996
Email: sales.support@microsemi.com
www.microsemi.com

© 2020 Microsemi. All rights reserved. Microsemi and the Microsemi logo are trademarks of Microsemi Corporation. All other trademarks and service marks are the property of their respective owners.

Microsemi makes no warranty, representation, or guarantee regarding the information contained herein or the suitability of its products and services for any particular purpose, nor does Microsemi assume any liability whatsoever arising out of the application or use of any product or circuit. The products sold hereunder and any other products sold by Microsemi have been subject to limited testing and should not be used in conjunction with mission-critical equipment or applications. Any performance specifications are believed to be reliable but are not verified, and Buyer must conduct and complete all performance and other testing of the products, alone and together with, or installed in, any end-products. Buyer shall not rely on any data and performance specifications or parameters provided by Microsemi. It is the Buyer's responsibility to independently determine suitability of any products and to test and verify the same. The information provided by Microsemi hereunder is provided "as is, where is" and with all faults, and the entire risk associated with such information is entirely with the Buyer. Microsemi does not grant, explicitly or implicitly, to any party any patent rights, licenses, or any other IP rights, whether with regard to such information itself or anything described by such information. Information provided in this document is proprietary to Microsemi, and Microsemi reserves the right to make any changes to the information in this document or to any products and services at any time without notice.

Microsemi, a wholly owned subsidiary of Microchip Technology Inc. (Nasdaq: MCHP), offers a comprehensive portfolio of semiconductor and system solutions for aerospace & defense, communications, data center and industrial markets. Products include high-performance and radiation-hardened analog mixed-signal integrated circuits, FPGAs, SoCs and ASICs; power management products; timing and synchronization devices and precise time solutions, setting the world's standard for time; voice processing devices; RF solutions; discrete components; enterprise storage and communication solutions; security technologies and scalable anti-tamper products; Ethernet solutions; Power-over-Ethernet ICs and midspans; as well as custom design capabilities and services. Microsemi is headquartered in Aliso Viejo, California, and has approximately 4,800 employees globally. Learn more at www.microsemi.com.

X-ON Electronics

Largest Supplier of Electrical and Electronic Components

Click to view similar products for [RF MOSFET Transistors](#) category:

Click to view products by [Microsemi](#) manufacturer:

Other Similar products are found below :

[MRF492](#) [MRFE8VP8600HR5](#) [ARF1511](#) [ARF465BG](#) [BF 2030 E6814](#) [BLF861A](#) [DU1215S](#) [DU28200M](#) [UF28100M](#) [DU2820S](#) [MRF426](#)
[ARF468AG](#) [ARF468BG](#) [MAPHST0045](#) [DU2860U](#) [MRFE6VP5300NR1](#) [BF2040E6814HTSA1](#) [LET9060S](#) [MRF136Y](#) [BF999E6327HTSA1](#)
[SD2931-12MR](#) [BF998E6327HTSA1](#) [AFT05MS006NT1](#) [MRF141](#) [MRF171](#) [MRF172](#) [MRF174](#) [SD2942](#) [QPD1020SR](#) [BF 1005S E6327](#)
[MRF134](#) [MRF136](#) [MRF137](#) [MRF141G](#) [MRF151A](#) [MRF151G](#) [MRF157](#) [MRF158](#) [MRF160](#) [MRF166C](#) [MRF171A](#) [MRF177](#) [UF2840G](#)
[TGF3021-SM](#) [ARF1510](#) [ARF448BG](#) [ARF449AG](#) [ARF466BG](#) [VRF150](#) [VRF3933](#)