

VSC7112

Two-lane PCI Express 3.0 Redriver with Adaptive EQ

Microsemi's PCIe redriver delivers excellent performance with flexible lane configuration for Gen 1/2/3 applications in a very small footprint.

VSC7112 is a high-performance, two-lane (quad-channel) asynchronous buffer that simplifies high-speed signal path designs (up to 8.5 Gbps) by providing Microsemi's industry-proven adaptive input equalization and output pre-emphasis. The device optimizes energy efficiency with innovative Green modes that reduce power consumption at lower data rates. Additional power savings can be achieved by deactivating unused channels and configuring the best output level settings for an application.

The VSC7112 device offers programmable, static, and adaptive equalization settings to provide a comprehensive solution for countering signal degradation over a wide variety of transmission cabling and interconnect paths. The small package and two-lane configuration make the device an excellent fit for a wide variety of PCIe server applications challenged with long traces, cables and connectors, as well as NVMe solid-state drives (SSDs).

Loss of signal (LOS) detectors with programmable thresholds are included on every input port. Each channel includes PCIe Gen 1/2/3 receiver detection and state machines. The VSC7112 can be configured for pass-through 4-channel buffer, dual 2 × 2 matrix, dual 1:2 duocast, or dual 2:1 selector configurations.

Highlights

- Up to 8.5 Gbps asynchronous operation
- Energy-efficient Green modes
- Adaptive equalization
- Ability to configure lanes as 4-channel buffer, 2x2 matrix, dual 1:2 duocast, or dual 2:1 selector

Applications

- PCIe Gen 1/2/3
- NVMe SSDs
- 1.5G, 3G, and 6G SAS/SATA

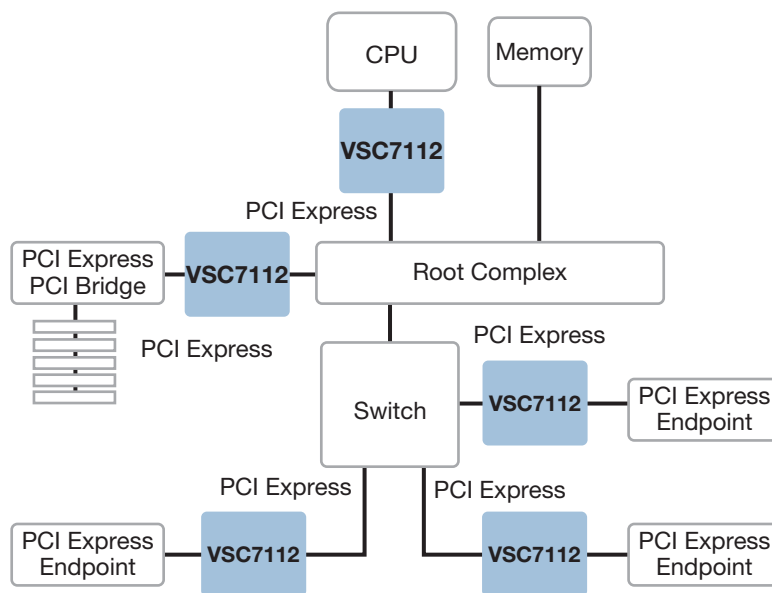

VSC7112

Two-lane PCI Express 3.0 Redriver with Adaptive EQ

Flexible Architecture

- Automatic (Adaptive) input equalization
- 0 Gbps to 8.5 Gbps asynchronous operation
- 4-channel buffer, dual 2 × 2 matrix, dual 1:2 duocast, or dual 2:1 selector configurations

Best-in-Class EQ

- Input EQ up to 30 dB
- Transmit pre-emphasis up to 10 dB
- Output up to 1600 mV differential peak-to-peak
- Input sensitivity 100 mV differential peak-to-peak

Power-Scaling Mode

- Power savings when running below 6.5 Gbps

Storage and Server Protocols

- PCIe Gen 1/2/3 receiver detection and state machines
- SAS/SATA-compatible loss of signal (LOS) detection and out-of-band (OOB) forwarding

Key Specifications

- 2.5 V power supply
- 160 mW typical power consumption per channel in full-power mode, 120 mW per channel in Green mode
- 32-pin, 5 mm × 5 mm QFN package

Related Products

Visit www.microsemi.com for information about these related products:

- Crosspoint Switches
- PCI Express Switches

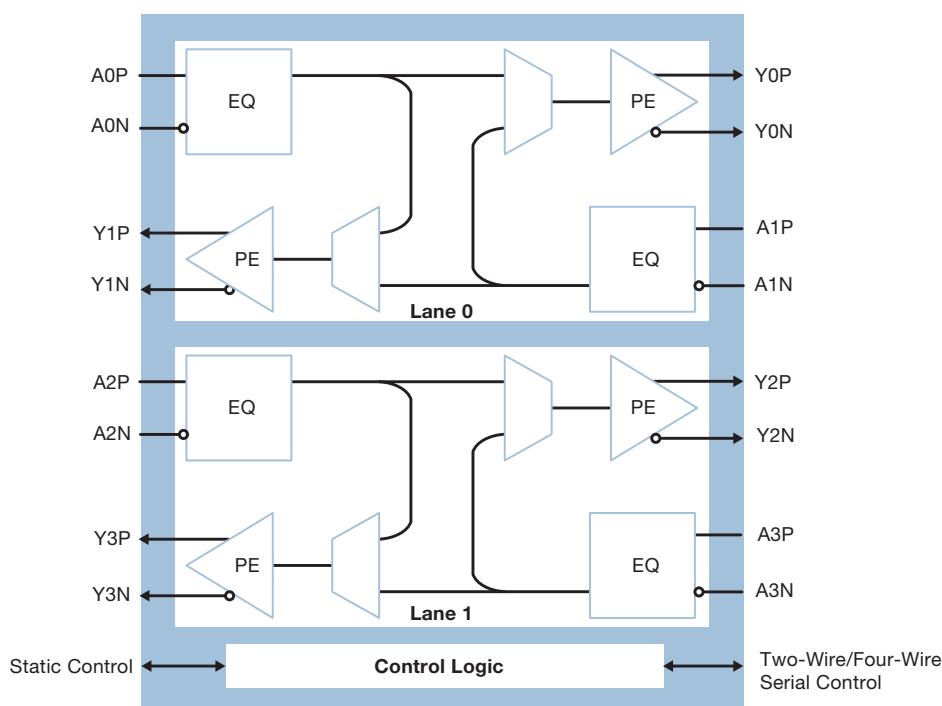

X-ON Electronics

Largest Supplier of Electrical and Electronic Components

Click to view similar products for [Equalisers](#) category:

Click to view products by [Microsemi](#) manufacturer:

Other Similar products are found below :

[M22554G-12](#) [M21424G-13](#) [PTN3944EWY](#) [M21518G-13](#) [EQCO30T5.2](#) [AD8195ACPZ-R7](#) [AD8192ACPZ-RL7](#) [AD8124ACPZ](#)
[AD8128ACPZ-R2](#) [AD8192ACPZ](#) [AD8194ACPZ](#) [AD8195ACPZ](#) [AD8197AASTZ](#) [ADV3002BSTZ](#) [ADV3003ACPZ](#) [ADV3003ACPZ-R7](#)
[GS1524-CKDE3](#) [MAX3814CHJ+T](#) [MAX3802UTK+D](#) [MAX3980UTH+](#) [MAX3815CCM+TD](#) [EQCO30R5.D](#) [MAX3814CHJ+](#)
[EQCO125T40C1T-I/8EX](#) [GS3440-INTE3](#) [MAX3984UTE+](#) [GS2964-INE3](#) [GS6042-INE3](#) [GS2974ACNE3](#) [GS2984-INE3](#) [GS3440-INE3](#)
[GS2993-INE3](#) [SN75LVPE802RTJT](#) [NB7VQ1006MMNG](#) [QPC7334SR](#) [QPC7335SR](#) [ISL54102ACQZ](#) [GS12141-INE3](#) [GS12341-INE3](#)
[GS12190-INE3](#) [GS3590-INE3](#) [VSC7224XJV-02](#) [LMH0044SQE/NOPB](#) [LMH0074SQE/NOPB](#) [DS30EA101SQ/NOPB](#) [LMH0344SQE/NOPB](#)
[LMH0344SQ/NOPB](#) [LMH0384SQE/NOPB](#) [LMH0384SQ/NOPB](#) [LMH0394SQ/NOPB](#)