

# VSC7224, VSC7224-01, and VSC7224-02

## 4-Channel Multirate Adaptive Retimer

Microsemi's EQNOX™ family of advanced unidirectional adaptive retimers equalize deteriorated input signals while dissipating the lowest possible power.

The VSC7224 devices are 4-channel unidirectional adaptive channel extenders with CDR. They incorporate analog and digital equalization, clock and data recovery, and output de-emphasis. VSC7224 supports data rates up to 12.5 Gbps. VSC7224-01 supports data rates up to 11.5 Gbps. VSC7224-02 supports data rates up to 10.3 Gbps.

The VSC7224 devices are simple-to-use copper media receivers and drivers that provide electrical compensation to cable, copper, and backplane environments to increase system margin and media driving distances. Target applications include Ethernet, Fibre Channel, Infiniband, CPRI, OTN, and many others, accomodating a wide collection of both standard and proprietary protocols. They equalize greater than 40 inches of FR-4 at 10 Gbps and greater than 10 m of 24AWG of copper direct-attached cable at 10 Gbps.

The VSC7224 devices can be used either on their own or with an external microcontroller to control, monitor, and enhance system performance.

The VSC7224 devices feature Microsemi's proprietary FlexEQ™ technology to equalize deteriorated input signals while dissipating the lowest possible power. A low-cost 25 MHz crystal, along with on-chip frequency synthesizers, allows for CDR operation at any data rate. Its three-tap FIR output driver architecture enables up to 18 dB of de-emphasis.

The VSC7224 devices include Microsemi's patented VScope input signal monitoring integrated circuit signal monitoring and waveform viewing technology.

### Highlights

- World-class adaptive equalization
- Up to 12.5 Gbps operation
- 18 dB programmable output de-emphasis
- Retimer and redriver modes
- Built-in VScope™
- On-chip frequency synthesizers

### Applications

- Line, backplane, and copper cable driver, receiver, and retimer
- PCB signal enhancement
- Optical module retimer and receiver

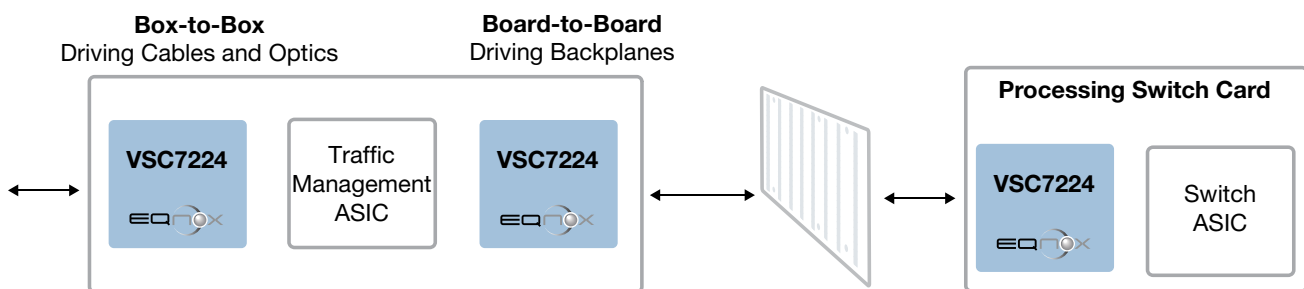

# VSC7224, VSC7224-01, and VSC7224-02

## 4-Channel Multirate Adaptive Retimer

### Key Benefits

- Simple-to-use device
- Low module and system power consumption
- Fully adaptive analog and digital equalization
- Wide range of data rate operation with 25 MHz crystal and built-in frequency synthesizers
- LOS detection
- Built-in VScope input signal monitoring integrated circuit eye diagram monitoring

### Architecture

- Two-wire serial port for optional microcontroller and VScope input signal monitoring integrated circuit
- Pin-strap option for operation without microcontroller
- World-class adaptive equalization: 28 dB input equalization, Four-tap decision feedback equalizer (DFE)
- Built-in diagnostics
- Two-wire serial interface

### Key Specifications

- 1.2 V single power supply
- 180 mW per channel power consumption (retimer)
- 110 mW per channel power consumption (re-driver)
- Compact 5 mm × 9 mm QFN package

### Related Products

Visit [www.microsemi.com](http://www.microsemi.com) for information about these related products:

- VSC7111 quad signal conditioner with up to 11.5 Gbps asynchronous operation
- VSC7227 twelve-channel multirate adaptive retimer with up to 15.5 Gbps operation

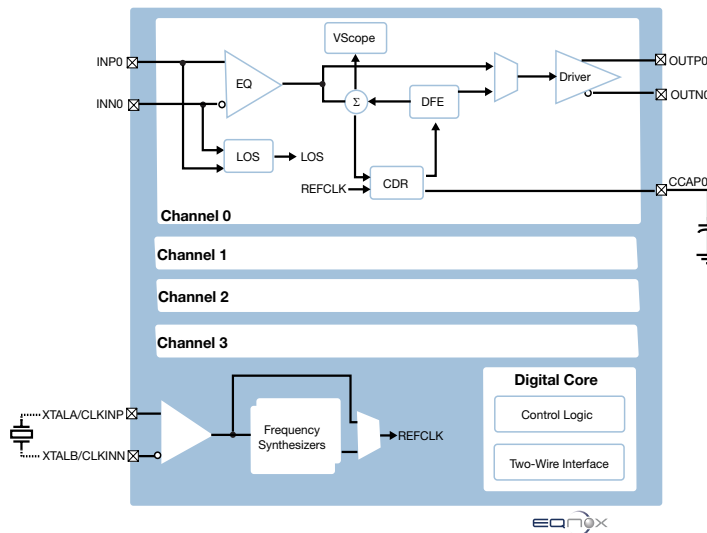

#### Microsemi Headquarters

One Enterprise, Aliso Viejo, CA 92656 USA  
 Within the USA: +1 (800) 713-4113  
 Outside the USA: +1 (949) 380-6100  
 Sales: +1 (949) 380-6136  
 Fax: +1 (949) 215-4996  
 email: [sales.support@microsemi.com](mailto:sales.support@microsemi.com)  
[www.microsemi.com](http://www.microsemi.com)

## X-ON Electronics

Largest Supplier of Electrical and Electronic Components

*Click to view similar products for [Equalisers](#) category:*

*Click to view products by [Microsemi](#) manufacturer:*

Other Similar products are found below :

[M22554G-12](#) [M21424G-13](#) [PTN3944EWY](#) [M21518G-13](#) [EQCO30T5.2](#) [AD8195ACPZ-R7](#) [AD8192ACPZ-RL7](#) [AD8124ACPZ](#)  
[AD8128ACPZ-R2](#) [AD8192ACPZ](#) [AD8194ACPZ](#) [AD8195ACPZ](#) [AD8197AASTZ](#) [ADV3002BSTZ](#) [ADV3003ACPZ](#) [ADV3003ACPZ-R7](#)  
[GS1524-CKDE3](#) [MAX3814CHJ+T](#) [MAX3802UTK+D](#) [MAX3980UTH+](#) [MAX3804ETE+](#) [MAX3787AWL+T](#) [MAX3815ACCM+](#)  
[MAX3815CCM+TD](#) [EQCO30R5.D](#) [MAX3814CHJ+](#) [EQCO125T40C1T-I/8EX](#) [GS3440-INTE3](#) [MAX3984UTE+](#) [MAX3982UTE+](#) [GS2964-](#)  
[INE3](#) [GS6042-INE3](#) [GS2974ACNE3](#) [GS2984-INE3](#) [GS3440-INE3](#) [GS2993-INE3](#) [SN75LVPE802RTJT](#) [NB7VQ1006MMNG](#) [QPC7334SR](#)  
[QPC7335SR](#) [ISL54102ACQZ](#) [VSC7111XJW](#) [GS12141-INE3](#) [GS12341-INE3](#) [GS12190-INE3](#) [GS3590-INE3](#) [VSC7224XJV-02](#)  
[LMH0044SQE/NOPB](#) [LMH0074SQE/NOPB](#) [DS30EA101SQ/NOPB](#)