

RECORD OF REVISION

Version	Revised Date	Page	Content
V1.0	2018/12/20	--	First Issued

TABLE OF CONTENTS

No.	Content	Page
	HDMI TFT Module Specification	1
	TABLE OF CONTENTS	3
1.	GENERAL DESCRIPTION	4
2.	MECHANICAL SPECIFICATION	5
3.	PIN DESCRIPTION	6
4.	ABSOLUTE MAXIMUM RATINGS	8
5.	BLOCK DIAGRAM	9
6.	ELECTRICAL CHARACTERISTICS	10
7.	OPTICAL CHARACTERISTICS	11
8.	RELIABILITY.....	14
9.	PRECAUTION RELATING PRODUCT HANDLING	20

1. GENERAL DESCRIPTION

1.1 Description

HA-215HVEE0GA0-A is a 21.5 (16:10) inch diagonally measured active display with high resolution 1920x1080 display. This model is composed of a TFT LCD panel, backlight system and HDMI included Stereo D/A Converter . It is designed to make Raspberry Pi usage easy. You can simply use this TFT display with your Raspberry Pi, or also you can use this as computer display with any device which has HDMI output. This 21.5" TFT model comes in 1920x1080 resolution that would be great for embedded computing usage too.

1.2 Features:

No.	Item	Specification	Unit
1	Panel Size	21.5"	Inch
2	Number of Pixels	1920 (W) x RGB x 1080 (H)	Pixels
3	Active Area	476.064 (W) x 267.786 (H)	mm
4	Pixel Pitch	0.24795 (W) x 0.24795 (H)	mm
5	Outline Dimension	495.6 (W) x 292.2 (H) x 27.4 (T)	mm
6	Number of Colors	16.7M	- -
7	Display Mode	Normally Black	- -
8	View Direction	Free direction	- -
9	Display Format	RGB vertical stripe	- -
10	Surface Treatment	Anti-Glare (3H)	- -
11	Contrast Ratio	3000 (Typ.)	- -
12	Luminance (cd/m ²)	250 (Typ.)	cd/m ²
13	Video Input Interface	HDMI (Compliance HDMI V1.4 and include HDCP decryption)	- -
14	Audio Output Interface	Analog Output	- -
15	Backlight	White LED	- -
16	Operation Temperature	0 ~ 50	°C
17	Storage Temperature	-20 ~ 60	°C
18	Weight	1830	g

3. PIN DESCRIPTION

3.1 Power Input(DC1) [DC JACK:SCD480CCS000B00GE or compatible]

Pin No.	Symbol	I/O	Function	Note
1	12V	P	Power Supply +12V	12.0V 
2	GND	P	Ground	

3.2 Power Input(DC2) [WAFER P2.0mm: 2001S-04-RTE or compatible]

Pin No.	Symbol	I/O	Function	Note
1	DC 12V	P	Power Supply +12V	
2	DC 12V	P	Power Supply +12V	
3	GND	P	Ground	
4	GND	P	Ground	

3.3 Power Input(DC3) [Eurostyle TERMINAL: VI0201520000GE or compatible]

Pin No.	Symbol	I/O	Function	Note
1	GND	P	Ground	
2	12V	P	Power Supply +12V	

3.4 Back-light Control(LED CONTROL) [WAFER P2.0mm:2001S-03-RTE or compatible]

Pin No.	Symbol	I/O	Function	Note
1	GND	P	Ground	
2	PWM	I	Back-light Dimming control (internal pull up to 3.3V)	*1
3	NC	I	No connection. (internal control)	

*1: When PWM not connected, back-light default is typical brightness.

3.5 Audio line out(LINE OUT 2) [WAFER P2.0mm:2001S-03-RTE or compatible]

Pin No.	Symbol	I/O	Function	Note
1	R_CH	A	HDMI Audio:Right Channel Analog Output	
2	GND	P	Ground	
3	L_CH	A	HDMI Audio:Left Channel Analog Output	

3.6 Standard 3.5mm Phone Jack (LINE OUT 1) [PHONE JACK:ST-301E or compatible]

HDMI Audio Analog Output

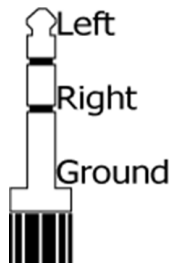

3.7 HDMI [HDMI A TYPE:PHD0911A2301E or compatible]

Pin No.	Symbol	I/O	Function	Note
1	TMDS 2+	I	TMDS Data2+	
2	GND	P	TMDS Data2 Shield	
3	TMDS 2-	I	TMDS Data2-	
4	TMDS 1+	I	TMDS Data1+	
5	GND	P	TMDS Data1 Shield	
6	TMDS 1-	I	TMDS Data1-	
7	TMDS 0+	I	TMDS Data0+	
8	GND	P	TMDS Data0 Shield	
9	TMDS 0-	I	TMDS Data0-	
10	TMDS CLK+	I	TMDS Clock+	
11	GND	P	TMDS Clock Shield	
12	TMDS CLK-	I	TMDS Clock-	
13	CEC	I	CEC	
14	N.C.	-	N.C.	
15	DDC_SCL	I	IIC SCL to EDID ROM	
16	DDC_SDA	I/O	IIC SDA to EDID ROM	
17	GND	P	DDC/CEC Ground	
18	HD_5V	P	+5V Power	
19	HPD	O	Hot Plug Detect	

3.8 DC OUTPUT (USB)

[USB TYPE-A: USAF-04*N-1BR605 or compatible]

Pin No.	Symbol	I/O	Function	Note
1	DC OUT	P	DC 5V OUTPUT	Max. 2A
2	NC	-	No connection.	
3	NC	-	No connection.	
4	GND	P	Ground	

4. ABSOLUTE MAXIMUM RATINGS

4.1 Electrical Absolute Rating

4.1.1 HDMI TFT LCD Module

Item	Symbol	Values		Unit	Note
		Min	Max.		
Power supply voltage	12V	TBD	14	V	

4.1.2 Environment Absolute Rating

Item	Symbol	Values			Unit	Note
		Min	Typ	Max.		
Operating Temperature	Top	0	-	50	°C	Ambient temperature
Storage Temperature	Tst	-20	-	60	°C	

5. BLOCK DIAGRAM

5.1 TFT LCD Module

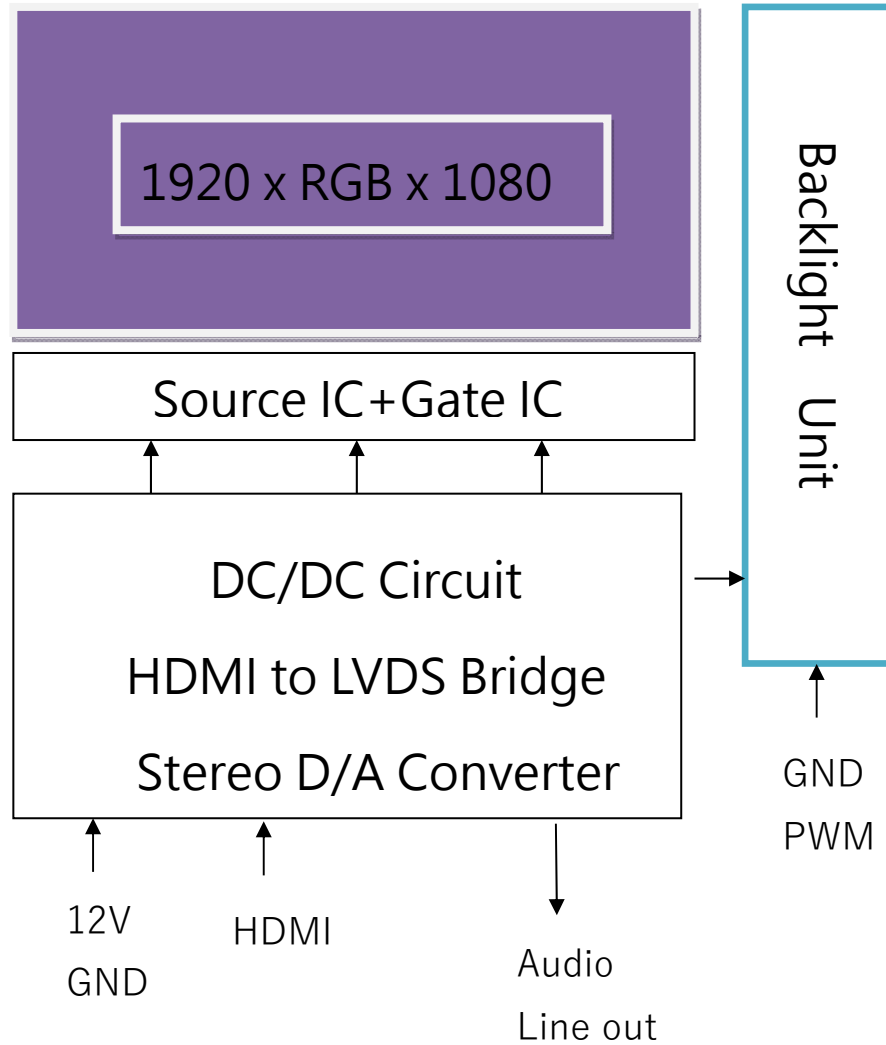

6. ELECTRICAL CHARACTERISTICS

6.1 HDMI TFT LCD Module

Item	Symbol	Values			Unit	Note
		Min	Typ.	Max.		
Supply Voltage	12V	TBD	12	13	V	
PWM frequency		100	-	10K	Hz	
PWM Duty		17	-	100	%	<17%=OFF
PWM Dimming Voltage	V _{PWM-IH}	3.3	-	8	V	
	V _{PWM-IL}	-	0.3	-	V	
LED Enable Control Voltage	V _{LED_EN-IH}	3.3	-	12	V	
	V _{LED_EN-IL}	-	-	0.5	V	
Supply Current	ICC(12V)	-	1280	1350	mA	Excluding USB DC OUTPUT
		-	2300	2400	mA	Including USB DC OUTPUT 5V,2A
LED life time		40000	-	-	Hr	(1)

Note 1:

The “LED life time” is defined as the module brightness decrease to 50% original brightness that the ambient temperature is 25°C 60% RH.

7. OPTICAL CHARACTERISTICS

Item	Symbol	Condition	Min.	Typ.	Max.	Unit
Brightness	--	Note1, Note 3, ($\theta = 0^\circ$; Normal Viewing Angle)	200	250	--	cd/m ²
Uniformity	B-uni		70	--	--	%
Contrast Ratio	CR		2000	3000	--	--
Response Time	Tr		--	20	25	ms
	Tf	--	5	10	ms	
Color Chromaticity	White	Wx	0.263	0.313	0.363	--
		Wy	0.279	0.329	0.379	--
View angle	Horizontal	θ_{x+}	80	89	--	
		θ_{x-}	80	89	--	
	Vertical	θ_{Y+}	80	89	--	
		θ_{Y-}	80	89	--	

Note : The following optical specifications shall be measured in a darkroom or equivalent state (ambient luminance ≤ 1 lux, and at room temperature). The operation temperature is $25^\circ\text{C} \pm 2^\circ\text{C}$. The measurement method is shown in Note1.

Note1: The method of optical measurement:

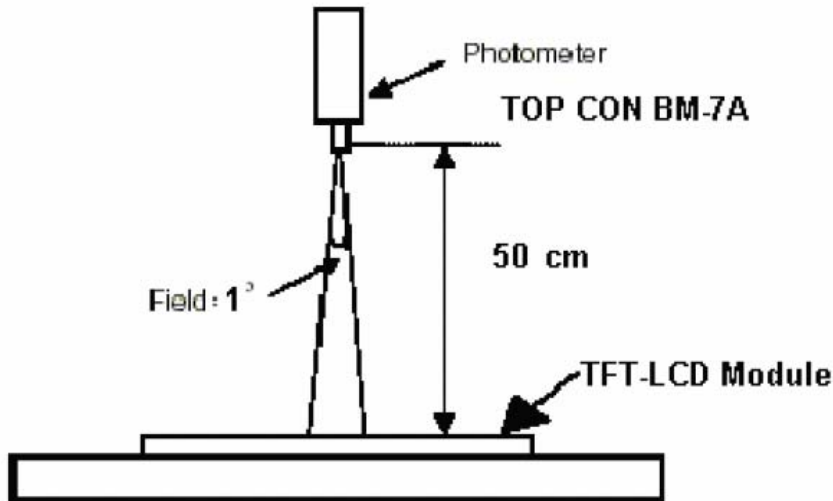

Note2: Measured at the center area of the panel and at the viewing angle of the $\theta_x = \theta_y = 0^\circ$

Note3: Definition of Contrast Ratio (CR):

CR = Luminance with all pixels in white state \div Luminance with all pixels in Black state

Note 4: Definition of Viewing Angle:

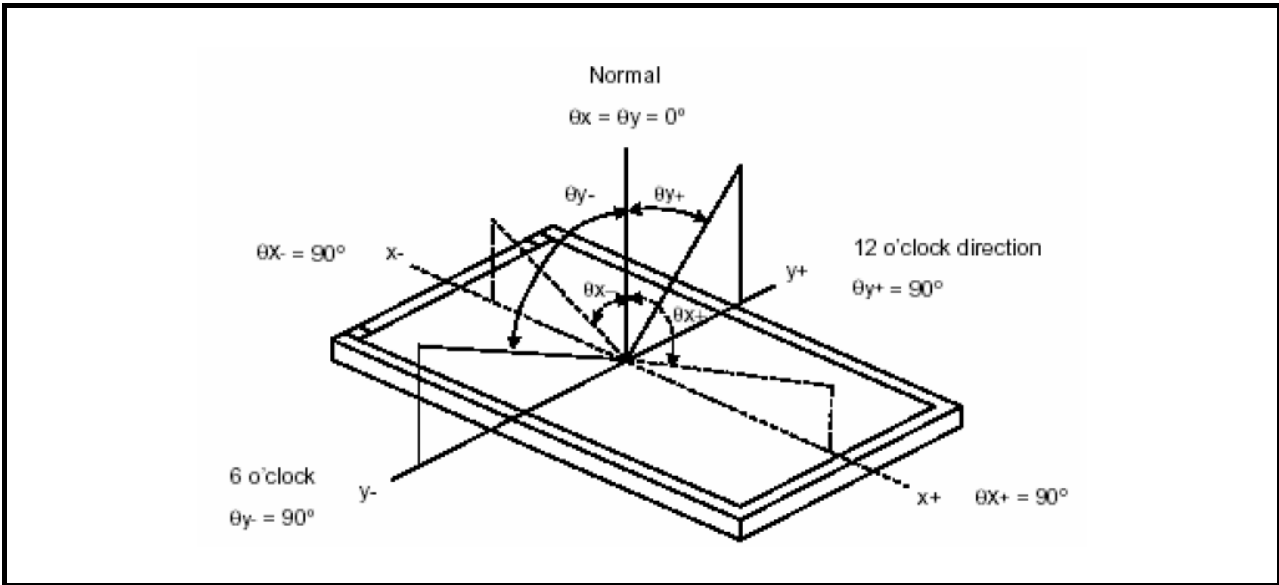

Note 5: Definition of Brightness Uniformity (B-uni):

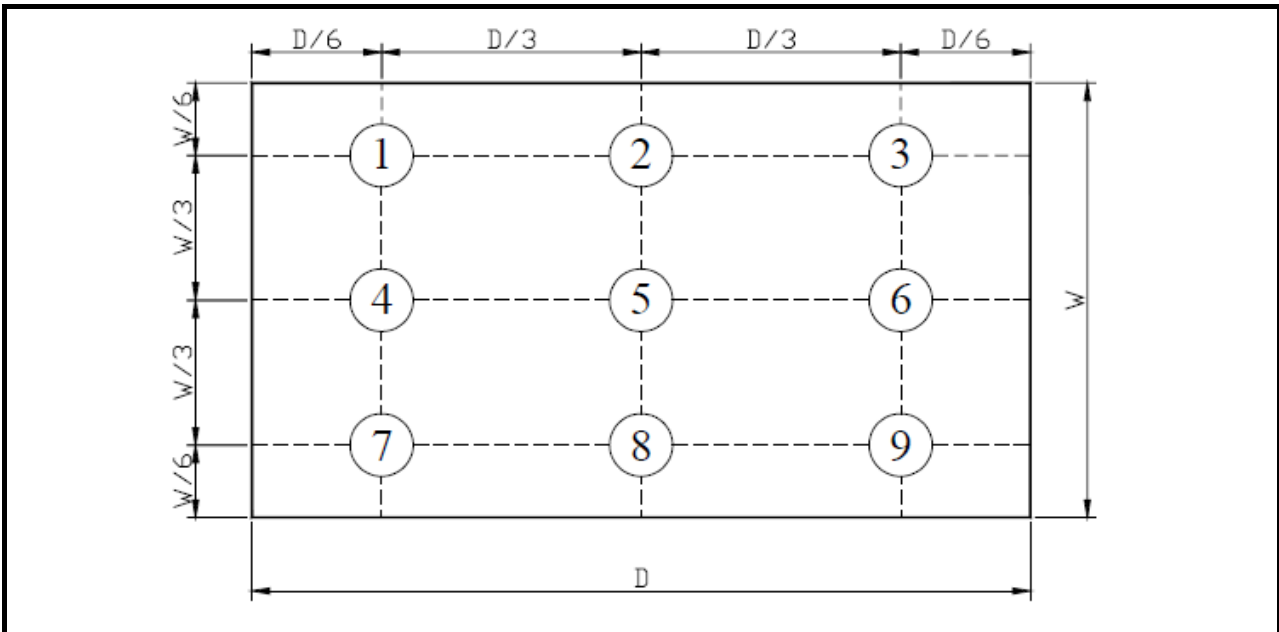

$B\text{-uni} = (\text{Minimum luminance of 9 points} \div \text{Maximum luminance of 9 points}) \times 100\%$

Note 6: Definition of Response Time:

The Response Time is set initially by defining the “Rising Time (Tr)” and the “Falling Time (Tf)” respectively. Tr and Tf are defined as following figure

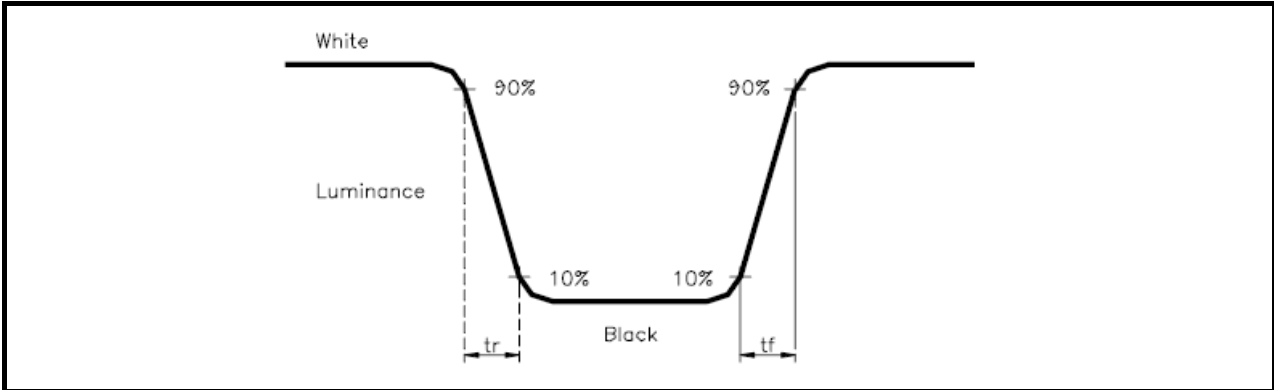

Note 7: Definition of Chromaticity:

The color coordinates (Wx,Wy), (Rx,Ry), (Gx,Gy), and (Bx,By) are obtained with all pixels in the viewing field at white, red, green, and blue states, respectively.

8. RELIABILITY

8.1 Test Condition

8.1.1 Temperature and Humidity(Ambient Temperature)

Temperature : $25 \pm 5^{\circ}\text{C}$

Humidity : $65 \pm 5\%$

8.1.2 Operation

Unless specified otherwise, test will be conducted under function state.

8.1.3 Container

Unless specified otherwise, vibration test will be conducted to the product itself without putting it in a container.

8.1.4 Test Frequency

In case of related to deterioration such as shock test. It will be conducted only once.

8.2 TESTS

No.	ITEM	CONDITION CRITERION
1	High Temperature Storage	60°C, 240 hrs
2	Low Temperature Storage	-20°C, 240 hrs
3	High Temperature Operating	50°C, 240 hrs
4	Low Temperature Operating	0°C, 240 hrs
5	High Temperature/Humidity Non-Operating	50°C, 80%RH, 240 hrs
6	Temperature Shock Non-Operating	-20°C \leftrightarrow 60°C (0.5hr each), 100 cycles
7	Vibration Test Non-Operating	Acceleration: 1.5 G Wave:sine Frequency: 10 - 300 Hz Sweep: 30 Minutes each Axis (X, Y, Z)
8	Electro-static Discharge	Contact Discharge: $\pm 8\text{KV}$,150pF(330 Ω) Air Discharge: $\pm 15\text{KV}$, 150pF(330 Ω)

Note1: The test sample have recovery time for 24 hours at room temperature before the function check. In the standard conditions, there is no any touch panel function NG issue occurred.

8.3 JUDGMENT STANDARD

The judgment of the above test should be made as follow:

Pass: Normal display image with no obvious non-uniformity and no line defect. Partial transformation of the module parts should be ignored.

Fail: No display image, obvious non-uniformity, or line defects.

8.4 INCOMING INSPECTION STANDARDS

Items		Acceptable count
Bright dot	Random	$N \leq 2$
	2 dots adjacent	$N \leq 1$
	3 dots adjacent or more	$N \leq 0$
Dark dot	Random	$N \leq 5$
	2 dots adjacent	$N \leq 2$
	3 dots adjacent or more	$N \leq 1$
Distance	Minimum Distance Between Bright dots	$L \geq 15\text{mm}$
	Minimum Distance Between Dark dots	$L \geq 15\text{mm}$
Total bright and dark dot		$N \leq 5$
Foreign Black/White/Bright Spot		$0.15 < D \leq 0.5 \text{ mm}, N \leq 4$
Foreign Black/White/Bright Lint		$0.05 < W \leq 0.1 \text{ mm}, 0.5 < L \leq 5.0 \text{ mm}, N \leq 4$
Display failure (V-line/H-line/Cross line etc.)		Not allowable
Mura	Not visible through 6% ND filter in 50% Gray pattern or judge by equivalent limit sample if necessary	

Inspection Item	Criteria and Description	Defect type
Vertical line	Signal input, vertical line off or irregular V-line appears	major
Horizontal line	Signal input, horizontal line off or irregular H-line appears	major
Cross line	Pattern signal input, a correct display is not obtained	major
No display	Signal input, display is dead	major
Irregular display	Pattern signal input, a correct display is not obtained	major
Dots defect	Exceed specified standards	minor
Scratch and Dent on polarizer	Exceed specified standards	minor
Foreign material	Exceed specified standards	minor
External Appearance	Rust, deformation, irregular plating, coating missing etc. A appearance defect that do not affect function or performance	minor
Bezel claw	Bezel claw missing or not bent	major
Polarizer bubble	Exceed specified standards	minor

Note1:

- (a) The definition of dot: The size of a defective dot over 1/2 of whole dot is regarded as one defective dot.
- (b) Bright dot: Dots appear bright and unchanged in size in which module is displaying under black pattern.
- (c) Dark dot: Dots appear dark and unchanged in size in which module is displaying under pure red, green , blue picture.
- (d) 2 dot adjacent = 1pair = 2 dots

Picture:



2 dot adjacent 2 dot adjacent 2 dot adjacent (vertical) 2 dot adjacent (slant)

- * Slight and tiny bright pixel defect are defined as the defective area is not greater than 50% of the dot area. They should be ignored.
- ** Press dot should be seen out of external pressure and dot area must greater than 50% of the dot area. If the press dot can disappear out of external pressure, it should be ignored.

Note2:

Item	Contents	
Screw	Parts mounting, incomplete assembly, deformation, oxidized, crooked or rusty is not permitted.	
Light Bar	FFC Break-off 、Connector Break-off / Burn-off is not permitted	
Metal frame (Bezel)	Scratch	*Noticeable scratch and exfoliation coating are not permitted. *The oxidized metal is not permitted.
	Incomplete assembly is not permitted.	
Backlight	Scratch	The scratch which may causes a problem in practical use is not permitted.
	Break-off	Breaking off is not permitted.
	Crack	The crack is not permitted.
Stain on Polarizer	The stain which can't be wiped off is not permitted.	
Tape/Label	Incorrect position, missed label is not permitted.	
Connector	Assembly NG or Function Fail caused by deformation is not permitted.	
Outline size	Spec. out is not permitted.	
Polarizer Scratches	$0.05 < W \leq 0.1 \text{ mm}, 0.5 < L \leq 10.0 \text{ mm}, N \leq 4$	
Dent/Air Bubble	Avg. $0.15 < D \leq 0.5 \text{ mm}, N \leq 4$	

Note : If any special defect is not included in the above table, this defect should be judged by INX/ODM /Brand customer discussion.

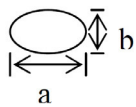

$$D=(a+b)/2$$

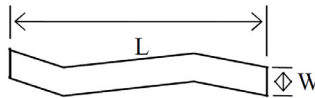

W: width, L : length

8.5 Classification of defects

Defects are classified two types, major defect and minor defect according to the defect. And, the definition of defects is classified as below.

8.5.1 Major defect

Any defect may result in functional failure, or reduce the usability of product for its purpose. For example, electrical failure, deformation and etc..

8.5.2 Minor defect

A defect that is not to reduce the usability of product for its intended purpose and un-uniformity, dot defect and etc..

The criteria on major and/or minor judgement will be according with the classification of defects.

8.6 Inspection conditions

The environmental condition and visual inspection shall be conducted as below.

8.6.1 Ambient temperature : 15~25°C

8.6.2 Humidity: 25~75%RH

8.6.3 Panel visual inspection on the operation condition for cosmetic shall be conducted at the distance

35±5 cm or more between the LCD module and eyes of inspector.

8.6.4 The viewing angle:

±15 degree to the front surface of display panel in vertical direction.

±45 degree to the front surface of display panel in horizontal direction.

8.6.5 Ambient Illumination:

Ambient Illumination: 400 ~ 600 Lux for external appearance inspection

Ambient Illumination: 100 ~ 200 Lux for light on inspection

8.6.6 Using method for ND Filter

When using ND Filter for judging Mura, placing ND Filter near Mura defect and get close to the surface of LCD Panel (its distance shall be 3~5cm between the surface of panel and ND Filter.) for 2~3sec. Don't touch the surface of polarizer to avoid scratching polarizer, and then move to the Defect position to judge mura by view angle 90 degree (The viewing angle shall be 90 degree to the right top of Mura defect with panel.)

9. PRECAUTION RELATING PRODUCT HANDLING

9.1 SAFETY

- 9.1.1 If the LCD panel breaks , be careful not to get the liquid crystal to touch your skin.**
- 9.1.2 If the liquid crystal touches your skin or clothes , please wash it off immediately by using soap and water.**

9.2 HANDLING

- 9.2.1 Avoid any strong mechanical shock which can break the glass.**
- 9.2.2 Avoid static electricity which can damage the CMOS LSI—When working with the module, be sure to ground your body and any electrical equipment you may be using.**
- 9.2.3 Do not remove the panel or frame from the module.**
- 9.2.4 The polarizing plate of the display is very fragile. So , please handle it very carefully, Do not touch, push or rub the exposed polarizing with anything harder than an HB pencil lead (glass , tweezers , etc.)**
- 9.2.5 Do not wipe the polarizing plate with a dry cloth, as it may easily scratch the surface of plate.**
- 9.2.6 Do not touch the display area with bare hands , this will stain the display area.**
- 9.2.7 Do not use ketonics solvent & aromatic solvent. Use with a soft cloth soaked with a cleaning naphtha solvent.**
- 9.2.8 To control temperature and time of soldering is $280 \pm 10^{\circ}\text{C}$ and 3-5 sec.**
- 9.2.9 To avoid liquid (include organic solvent) stained on LCM.**

9.3 STORAGE

- 9.3.1 Store the panel or module in a dark place where the temperature is $25^{\circ}\text{C} \pm 5^{\circ}\text{C}$ and the humidity is below 65% RH.**
- 9.3.2 Do not place the module near organics solvents or corrosive gases.**
- 9.3.3 Do not crush, shake, or jolt the module.**

X-ON Electronics

Largest Supplier of Electrical and Electronic Components

Click to view similar products for [TFT Displays & Accessories category](#):

Click to view products by [Microtips manufacturer](#):

Other Similar products are found below :

[HDA430T-3G1H](#) [NB7W-KBA04](#) [NB5Q-ATT01](#) [NB5Q-KBA04](#) [NB-CN001](#) [OAI-80038AA-2008-A](#) [315-U004B15300](#) [T-55619GD065J-LW-ABN](#) [TCG104SVLPEANN-AN30](#) [NL6448BC33-70](#) [NL6448BC20-30D](#) [NL10276BC16-06](#) [NL192108AC10-01D](#) [NL8060BC26-35BA](#) [NL8060BC31-50F](#) [TM070DDHG03-40](#) [PTPW16-070WV1S02](#) [PTPW17-070WV1S02](#) [PTPW16-084SV1S02](#) [MTD0300ECP06DF-1](#) [DEM 320240T VMX-PW-N \(A-TOUCH\)](#) [DEM 480128B TMH-PW-N \(A-TOUCH\)](#) [DEM 480272P VMX-PW-N \(C-TOUCH\)](#) [DEM 480272Q VMX-PW-N \(A-TOUCH\)](#) [DEM 480272Q VMX-PW-N \(C-TOUCH\)](#) [DEM 640480E TMH-PW-N \(A-TOUCH\)](#) [DEM 800480K1 TMH-PW-N \(A-TOUCH\)](#) [DEM 800480K1 TMH-PW-N \(C-TOUCH\)](#) [DEM 800480K2 TMH-PW-N \(A-TOUCH\)](#) [DEM 800480K3 TMH-PW-N \(C-TOUCH\)](#) [DEM 800480K4 TMH-PW-N \(A-TOUCH\)](#) [DEM 800480K4 TMH-PW-N \(C-TOUCH\)](#) [4DLCD-35480320-CTP-IPS](#) [4DLCD-35480320-IPS](#) [4DLCD-35480320-RTP-IPS](#) [4DLCD-50800480-CTP-IPS](#) [RFA6400E-AWH-DNG](#) [RFA6400E-AWH-MNN](#) [RFE430V-AZW-DNS](#) [RFF70VA2-1IW-DHS](#) [RFH700A8-AYH-MNN](#) [RFK101VF-1YH-LHG](#) [RFS390C-AIW-DNN](#) [RFS390C-AIW-DNS](#) [RFS52VA-1ZH-DHN](#) [SM-RVT101HVHFWCA0](#) [SM-RVT101HVHFWN00](#) [SM-RVT101HVHNWCA0](#) [SM-RVT101HVHNWN00](#) [SM-RVT101HVLFWCA0](#)