

The logo features a stylized graphic of three slanted bars in red, green, and blue.

Microtips

TECHNOLOGY

Model No: MTÖF€I €SZŠ

TEL: 1-888-499-TIPS (8477)

FAX: (407) 273-0771

E-MAIL: mtusainfo@microtipsusa.com

WEB: www.microtipsusa.com

Record of Revision

Date	Revision No.	Summary
2017-04-05	1.0	Rev 1.0 was issued

1. Scope

This data sheet is to introduce the specification of **MTD1040KZL** active matrix TFT module. It is composed of a color TFT-LCD panel, driver ICs, FPC, convert board and a backlight unit. The 10.4" display area contains 1024x3(RGB)x768 pixels.

2. Application

Digital equipments which need color display, mobile navigator/video systems, tablet PC.

3. General Information

Item	Contents	Unit
Size	10.4	inch
Resolution	1024x3(RGB) x 768	/
Interface	LVDS	/
Technology type	IPS	/
Pixel pitch	0.20625 x 0.20625	mm
Pixel Configuration	RGB stripes	
Outline Dimension (W x H x D)	238.6 x 175.8 x 6.5	mm
Active Area	211.2 x 158.4	mm
Display Mode	Transmissive, Normally Black	/
Backlight Type	LED	/

4. Outline Drawing

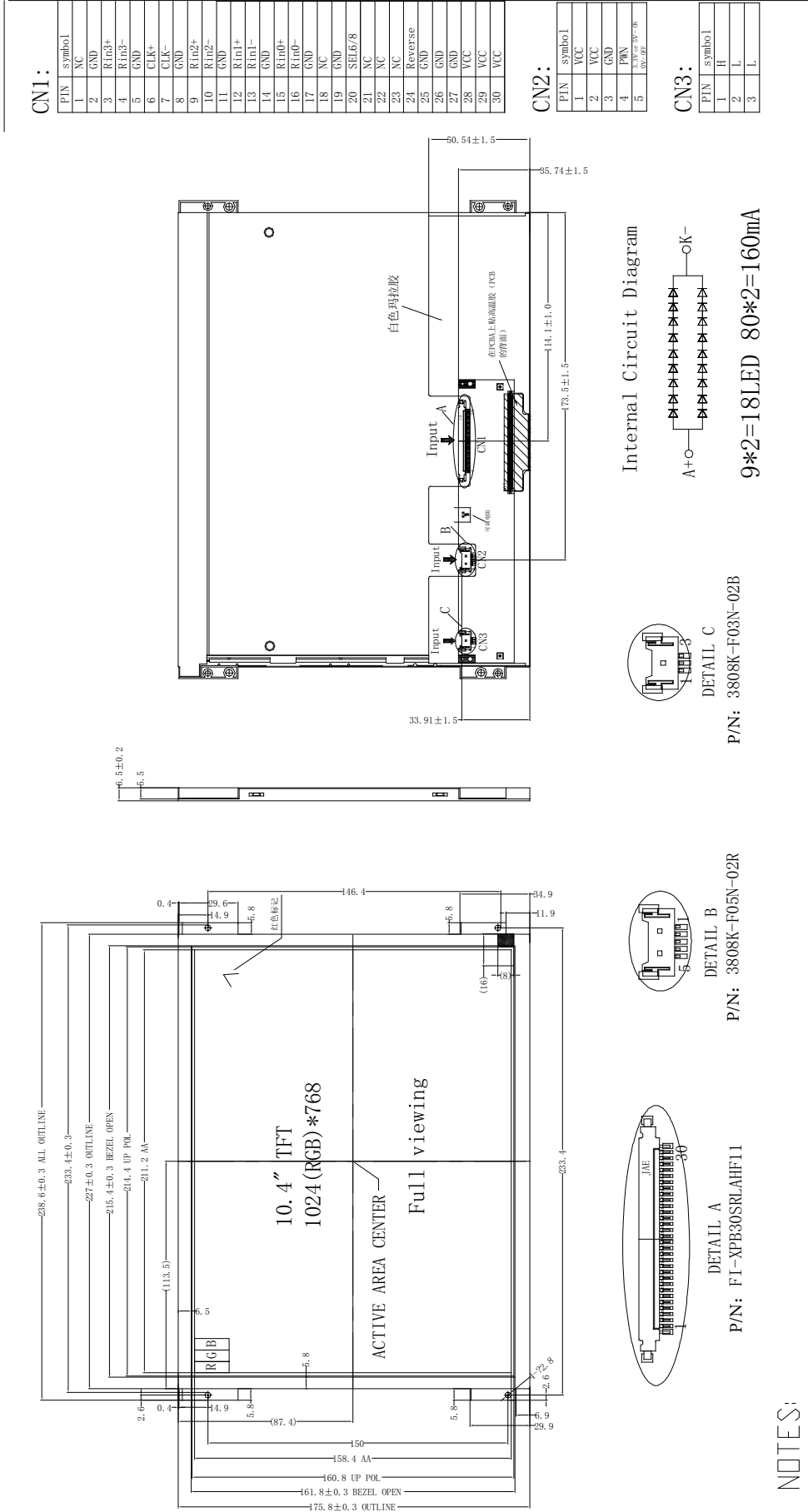

Microtips TECHNOLOGY	
DRAWN BY:	TITLE: MTD%(\$)?N@
CHECKED BY:	SCALE:
APPROVED BY:	DWG NO:
CONFIRMED BY:	DWG NAME:
	UNIT: mm
	SHEET NO: OF

5. Interface signals

CN1: The module using a LVDS receiver. LVDS is a differential signal technology for LCD interface and a high-speed data transfer device.

Pin No.	Symbol	Function	Remark
1	NC	No connection	
2	GND	Power ground	
3	Rin3+	+LVDS differential data input	
4	Rin3-	-LVDS differential data input	
5	GND	Power ground	
6	CLK+	+LVDS differential clock input	
7	CLK-	-LVDS differential clock input	
8	GND	Power ground	
9	Rin2+	+LVDS differential data input	
10	Rin2-	-LVDS differential data input	
11	GND	Power ground	
12	Rin1+	+LVDS differential data input	
13	Rin1-	-LVDS differential data input	
14	GND	Power ground	
15	Rin0+	+LVDS differential data input	
16	Rin0-	-LVDS differential data input	
17	GND	Power ground	
18	NC	No connection	
19	GND	Power ground	
20	SEL6/8	6bit/8bit mode select	
21	NC	No connection	
22	NC	No connection	
23	NC	No connection	
24	Reverse	Reverse Panel Function (Display Rotation)	
25	GND	Power ground	
26	GND	Power ground	
27	GND	Power ground	
28	VCC	Digital power	
29	VCC	Digital power	
30	VCC	Digital power	

CN2: LED Backlight Unit (Driver Connector)

Pin No.	Symbol	Function	Remark
1	VCC	Voltage input 12V	
2	VCC	Voltage input 12V	
3	GND	Power ground	
4	PWN	PWM brightness dimming pin (200HZ-20KHZ)	
5	ON/OFF	3.3V or 5V-ON,0V-OFF	

CN3: LED Backlight Unit (Light bar Connector)

Pin No.	Symbol	Function	Remark
1	H	LED anode	
2	L	LED cathode	
3	L	LED cathode	

6. Absolute maximum Ratings

6.1. Electrical Absolute max. ratings

Ta=25°C

Parameter	Symbol	Values			Unit	Remark
		MIN	Typ	MAX		
Digital supply Voltage	VDD VDD_LVDS	-0.3	-	5	V	
Analog Supply Voltage	AVDD	-0.5	-	15	V	
Gate On Voltage	VGH	-0.3	-	28	V	
Gate off Voltage	VGL	-20	-	0.3	V	
Gate On-Gate Off Voltage	VGH-VGL	-0.3	-	40	V	

6.2. Environment Conditions

Item	Symbol	MIN	MAX	Unit	Remark
Operating Temperature	TOPR	-20	70	°C	
Storage Temperature	TSTG	-30	80	°C	

7. Electrical Specifications

7.1 LCD Module Electrical characteristics

Item	Symbol	Values			Unit	Remark
		MIN	TYP	MAX		
Digital supply Voltage	VDD	3	3.3	3.6	V	
TFT Gate ON Voltage	VGH	20	25.2	28	V	
TFT Gate OFF Voltage	VGL	-8.5	-10.5	-12	V	
TFT Common Electrode Voltage	VCOM	4.5	5.5	6.5	V	
Analog Power Supply Voltage	AVDD	10.1	12.1	15	V	

Note: TYP VCOM is only reference value. It must be optimized according to each LCM. Be sure to use VR and OP buffer on VCOM output. Please adjust VCOM to make the flicker level be minimum for getting excellent image.

7.2 Current Consumption

Item	Symbol	Condition	Values			Unit	Remark
			MIN	TYP	MAX		
Digital Current	IVDD	VDD=3.3V	-	400	-	mA	

7.3 Backlight

Item	Symbol	Values			Unit	Remark
		MIN	TYP	MAX		
LED Current	ILED		160		mA	Total LED
Forward Voltage	VF	-	32.4	13.6	V	IF=160mA
Reverse Current	Ir	-	-	50	μA	VR=5V,1LED
Power dissipation	Pd		5184		mW	Total LED
Peak forward current	I _{fp}		100		mA	1LED
Reverse voltage	VR		5		V	1LED

Internal Circuit Diagram

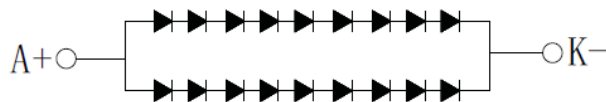

$9 * 2 = 18 \text{LED}$ $80 * 2 = 160 \text{mA}$

8. Command/AC Timing

8.1 AC Electrical Characteristics

8.1.1 LVDS Mode AC Electrical Characteristics

Parameter	Symbol	Values			Unit	Remark
		Min.	Typ.	Max.		
Clock frequency	RXFCLK	20	-	71	MHz	
Input data skew margin	TRSKM	500	-	-	pS	VID =400mV RXVCM =1.2V RXFCLK =71MHz
Clock high time	TLVCH	-	$4/(7 * \text{RXFCLK})$	-	ns	
Clock low time	TLVCL	-	$3/(7 * \text{RXFCLK})$	-	ns	
PLL wake-up time	TemPLL	-	-	150	μs	

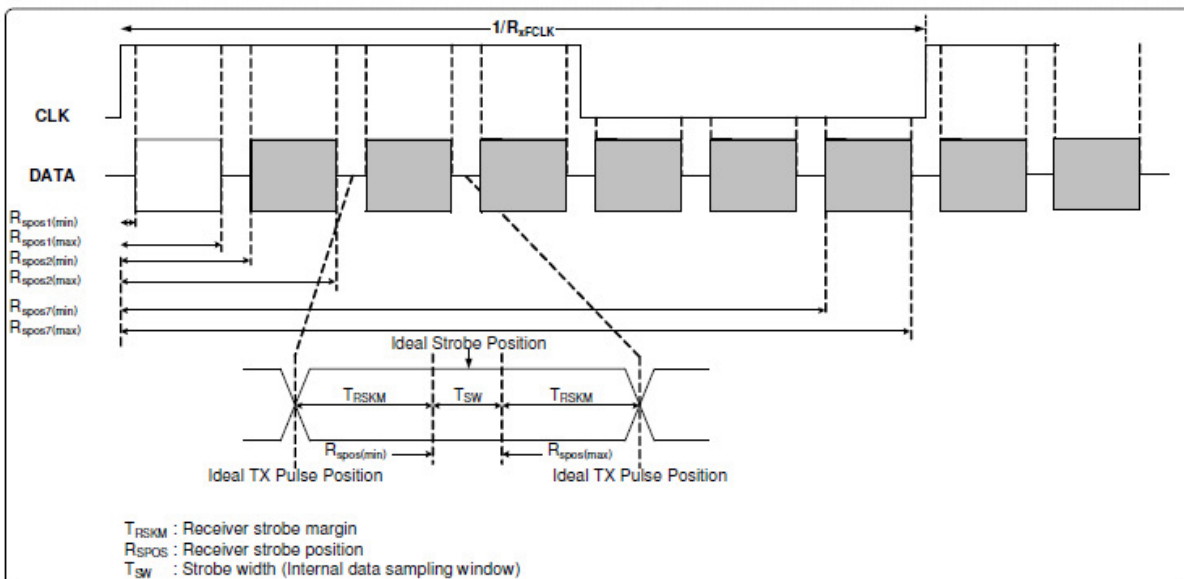
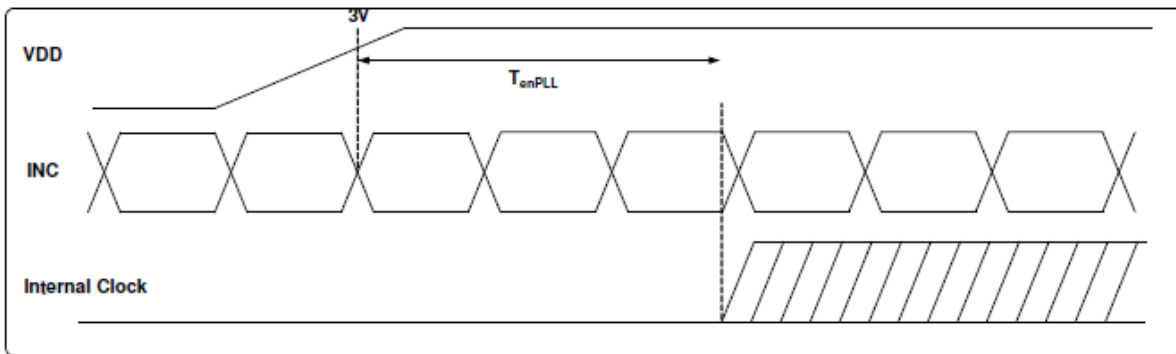
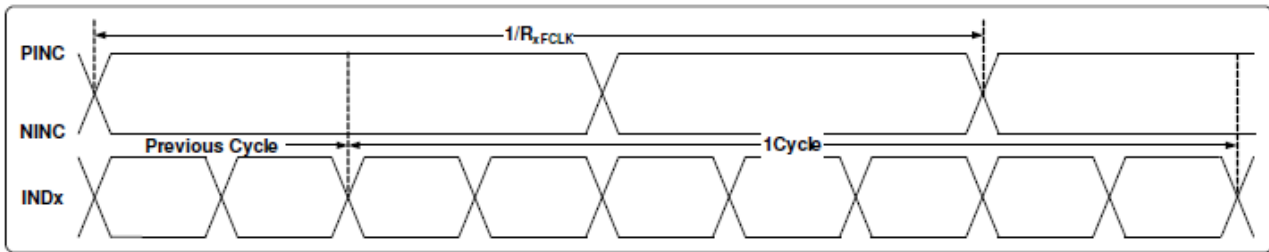

8.2 DC Electrical Characteristics

LVDS MODE DC Electrical Characteristics

Parameter	Symbol	Values			Unit	Remark
		Min.	Typ.	Max.		
Differential input high Threshold voltage	RxVTH	-	-	+0.1	V	RXVCM=1.2V
Differential input low threshold voltage	RxVTL	-0.1	-	-	V	
Input voltage range (singled-end)	RxVIN	0	-	VDD-1.2+ VID /2	V	-
Differential input common Mode voltage	RXVCM	VID /2	-	VDD-1.2	V	-
Differential input voltage	VID	0.2	-	0.6	V	-
Differential input leakage Current	RVXliz	-10	-	+10	μA	-
LVDS Digital Operating Current	Iddlvs	-	15	30	mA	Fclk=65MHz, VDD=3.3V
LVDS Digital Stand-by Current	Istlvds	-	10	50	μA	Clock & all Functions are stopped

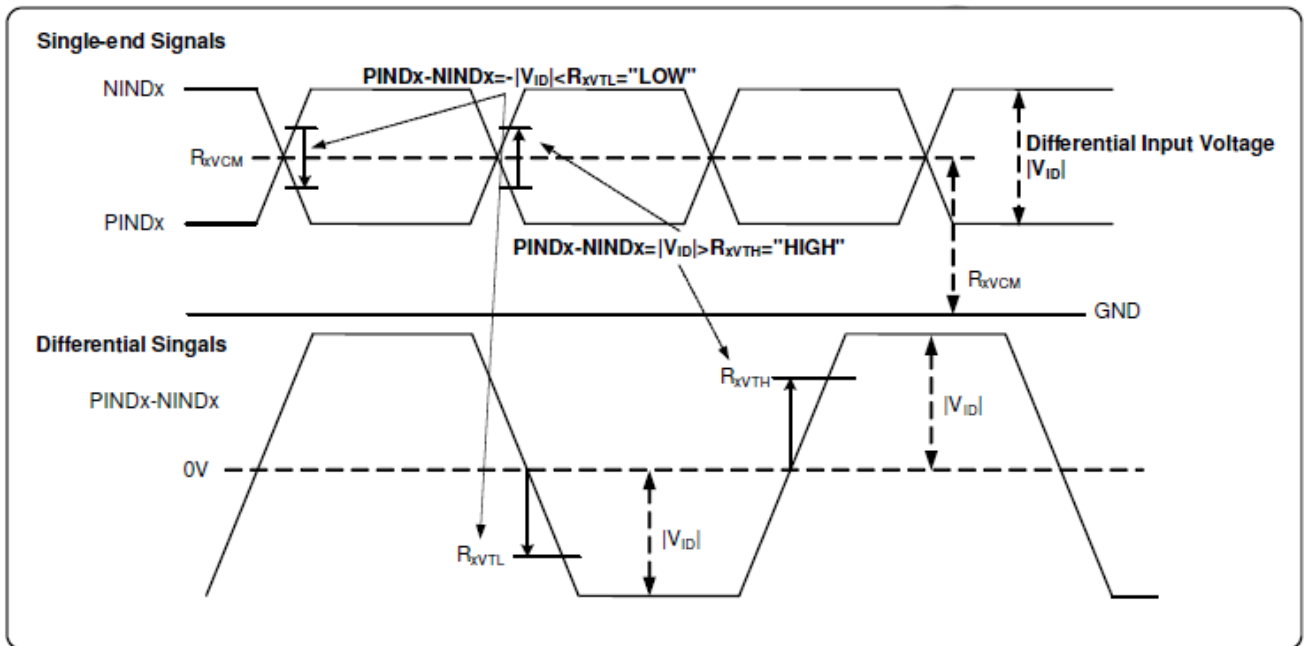

8.3 DATA INPUT FORMAT

LVDS Mode Data Input Format

8.3.1 6-bits LVDS Input

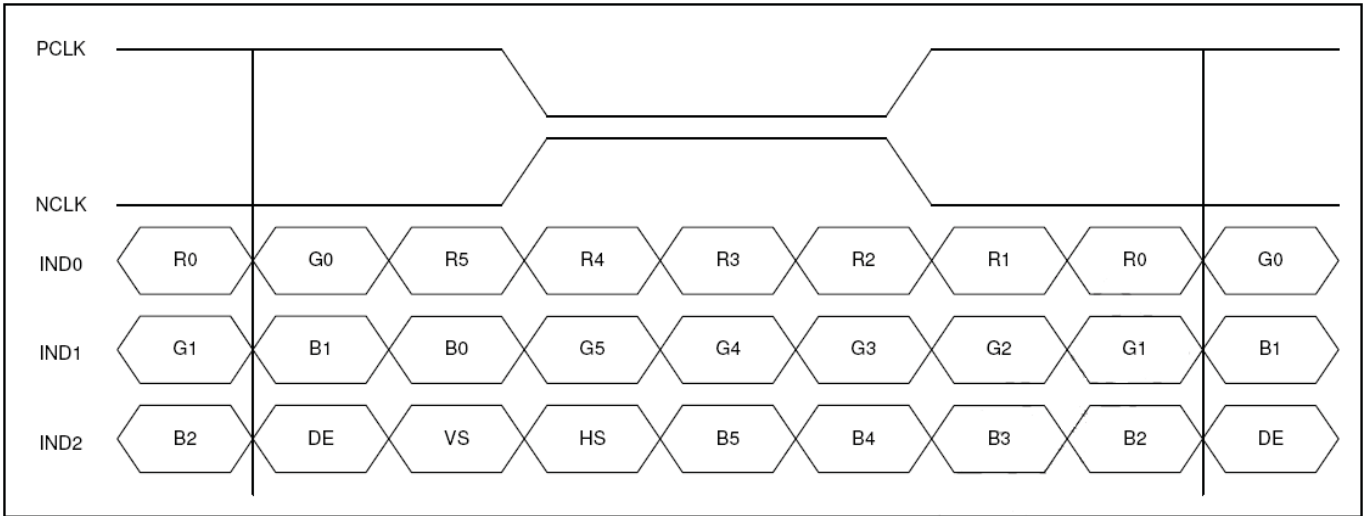

8.3.2 8-bits LVDS Input

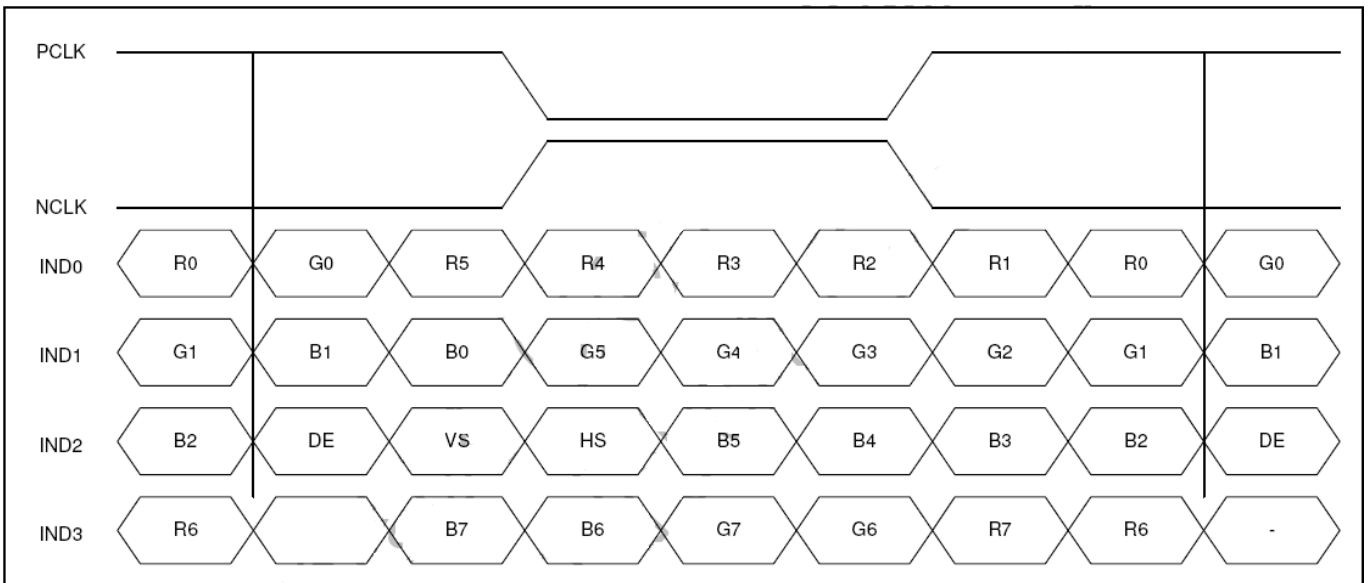

8.4 INPUT TIMING TABLE
8.4.1 DE Mode

Parameter	Symbol	Spec.			Unit
		Min.	Typ.	Max.	
DCLK Frequency	fclk	40.8	57	67	MHz
Horizontal Display Area	thd	1024			DCLK
HS Period	th	1114	1344	1400	DCLK
HS Blanking	thb+ thfp	90	320	376	DCLK
Vertical Display Area	tvd	768			TH
VS Period	tvbp	740	785	840	TH
VS Blanking	Tvbp+tvfp	10	38	77	TH

8.4.2 HV Mode
Horizontal timing

Parameter	Symbol	Spec.			Unit
		Min.	Typ.	Max.	
DCLK Frequency	fclk	40.8	51	67	MHz
Horizontal Display Area	thd	1024			DCLK
HS Period	th	1200	1344	1400	DCLK
HS Pulse width	thpw		10		DCLK
HS Back Porch	thbp		160		DCLK
HS Front Porch	thfp		160		DCLK

Vertical Timing

Parameter	Symbol	Spec.			Unit
		Min.	Typ.	Max.	
Vertical Display Area	tVd	768			TH
VS Period	tV	740	785	840	TH
VS Pulse width	tVpw		1		TH
VS Back Porch	tVbp	23			TH
VS Front Porch	tVfp		15		TH

8.5 Power ON/OFF Sequence

To prevent the device damage from latch up, the power on/off sequence shown below must be followed.

Power on: VDD, GND _ AVDD, AGND _ V1 to V14

Power off: V1 to V14 _ AVDD, AGND _ VDD, GND

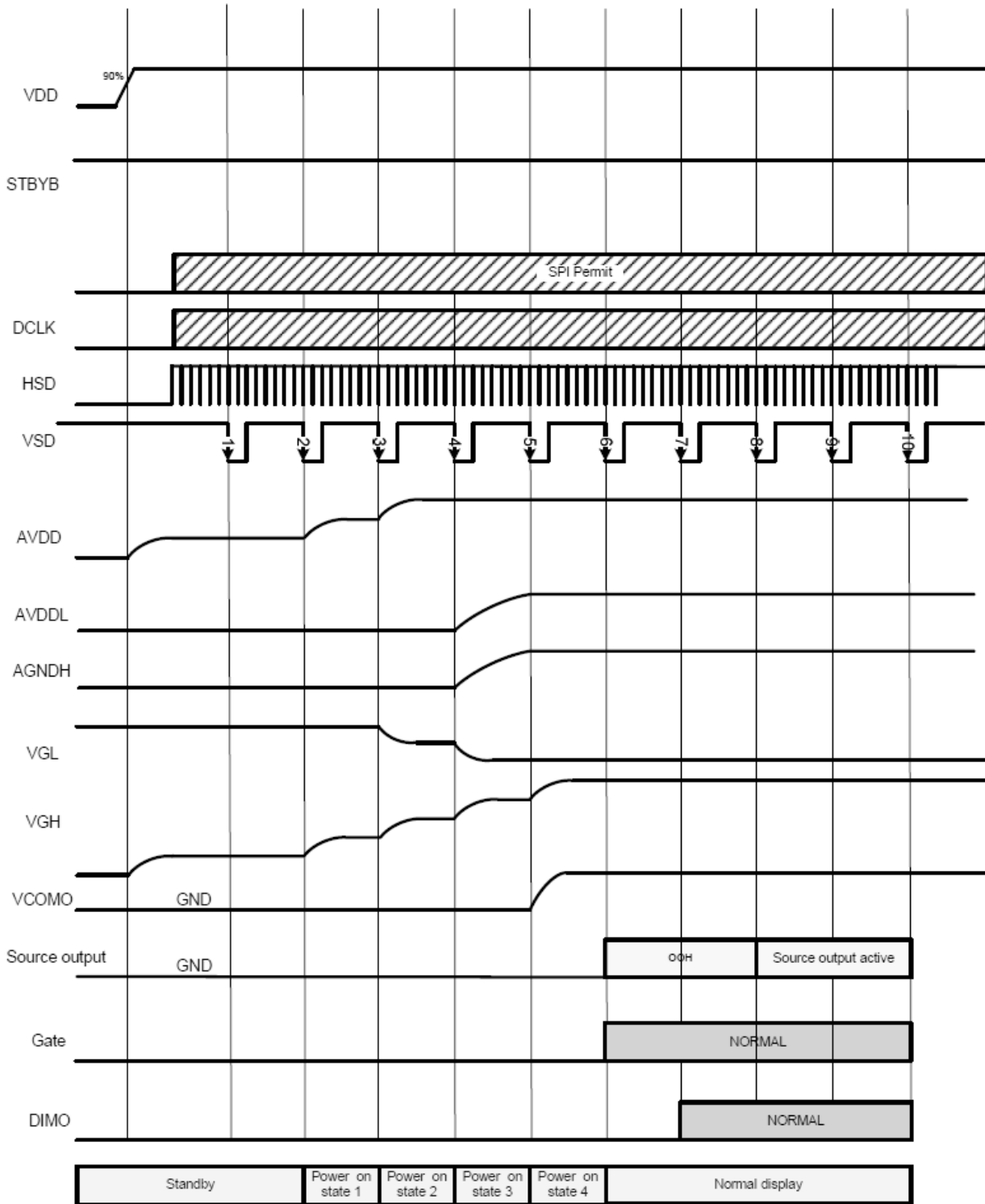

Note: Low level=3FH, when NBW=L (Normally white)

Low level=00H, when NBW=H (Normally black)

9. Optical Specification

Ta=25°C

Item	Symbol	Condition	Min	Typ.	Max.	Unit	Remark
Contrast Ratio	CR	$\theta=0^\circ$	-	500	-		Note1 Note2
Response Time	TRT	25°C	-	20	40	ms	Note1 Note3
View Angles	θT	$CR \geq 10$	-	80	-	Degree	Note 4
	θB		-	80	-		
	θL		-	80	-		
	θR		-	80	-		
Chromaticity	White	x	Brightness is on	0.279	0.329	0.379	Note5, Note1
		y		0.312	0.362	0.412	
	Red	x		0.752	0.802	0.852	
		y		0.144	0.194	0.244	
	Green	x		0.243	0.293	0.343	
		y		0.582	0.632	0.682	
	Blue	x		0.091	0.141	0.191	
		y		0.01	0.060	0.110	
Luminance	L		370	420	-	cd/m ²	Note1 Note6
Uniformity	U		70	75	-	%	Note1 Note7

Note 1: Definition of optical measurement system.

Temperature = 25°C(±3°C)

LED back-light: ON, Environment brightness < 150 lx

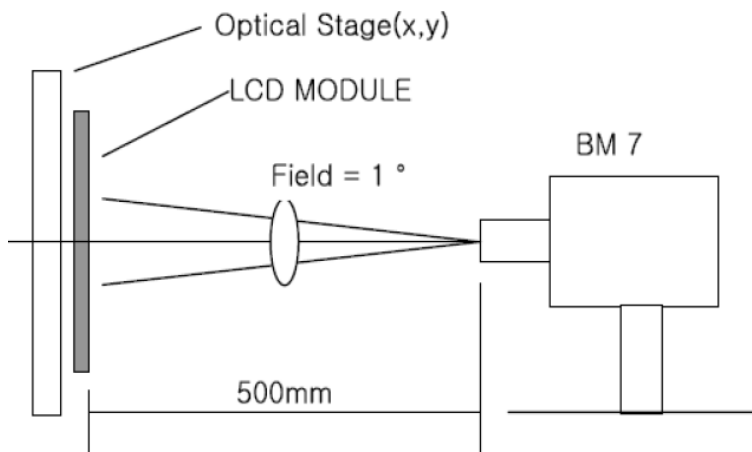

Note 2: Contrast ratio is defined as follow:

$$\text{Contrast Ratio} = \frac{\text{Surface Luminance with all white pixels}}{\text{Surface Luminance with all black pixels}}$$

Note 3: Response time is defined as follow:

Response time is the time required for the display to transition from black to white (Rise Time, T_r) and from white to black (Decay Time, T_f).

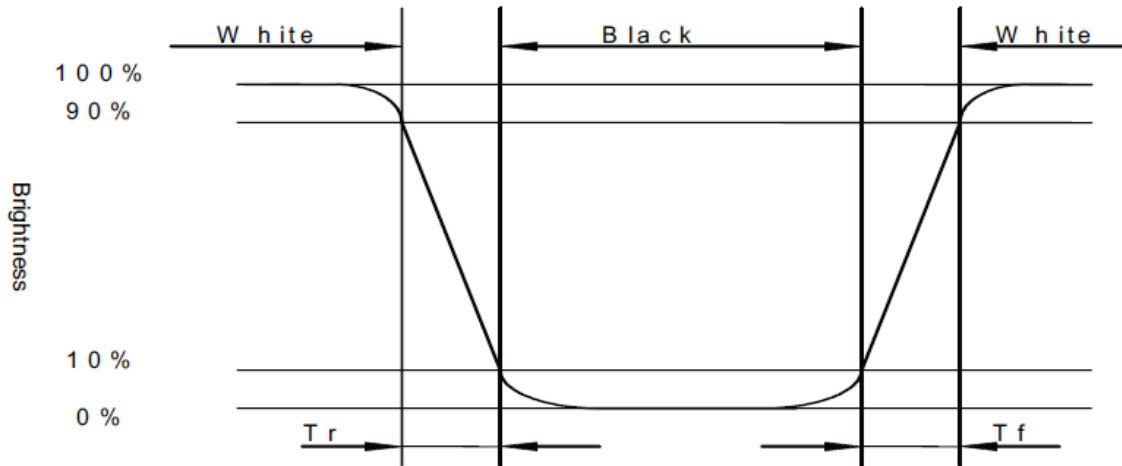

Note 4: Viewing angle range is defined as follow:

Viewing angle is measured at the center point of the LCD.

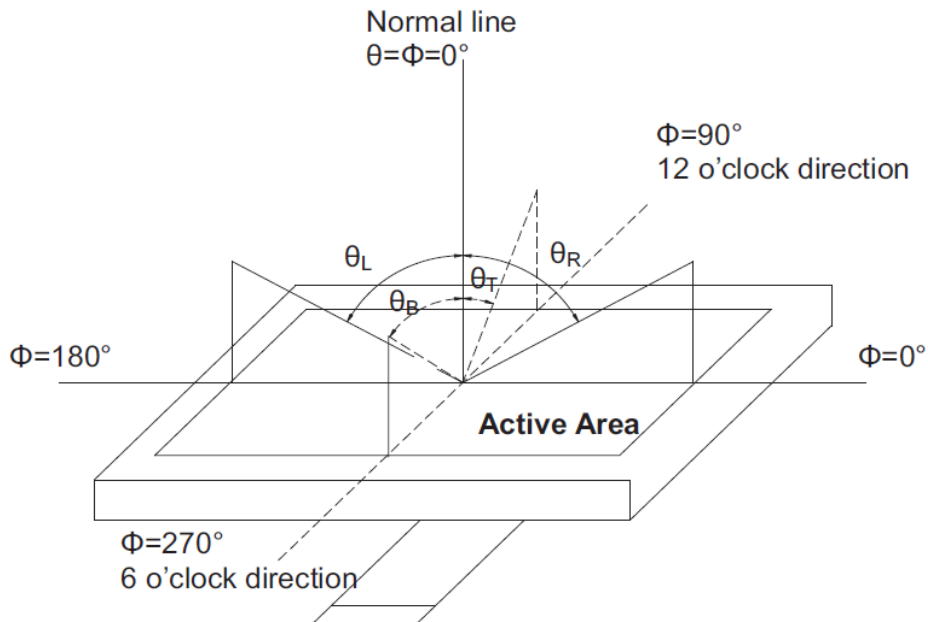

Note 5: Color chromaticity is defined as follow: (CIE1931)

Color coordinates measured at center point of LCD.

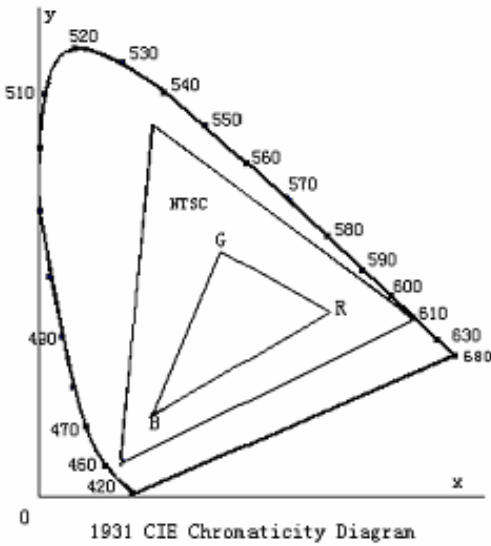

$$S = \frac{\text{area of RGB triangle}}{\text{area of NTSC triangle}} \times 100\%$$

Note 6: Luminance is defined as follow:

Luminance is defined as the brightness of all pixels “White” at the center of display area on optimum contrast.

Note 7: Luminance Uniformity is defined as follow:

Active area is divided into 9 measuring areas (Refer Fig. 2). Every measuring point is placed at the center of each measuring area.

$$\text{Uniformity}(U) = \frac{\text{Minimum Luminance(brightness) in 9 points}}{\text{Maximum Luminance(brightness) in 9 points}}$$

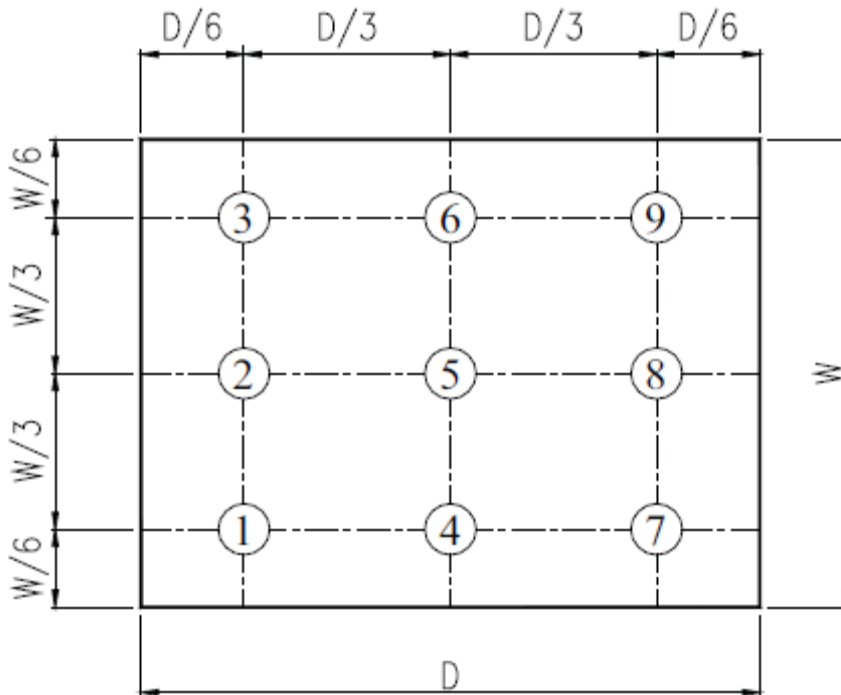

Fig. 2 Definition of uniformity

10. Environmental / Reliability Tests

No	Test Item	Condition	Judgment criteria
1	High Temp Operation	Ts=+70°C, 120hrs	Per table in below
2	Low Temp Operation	Ta=-20°C, 120hrs	Per table in below
3	High Temp Storage	Ta=+80°C, 120hrs	Per table in below
4	Low Temp Storage	Ta=-30°C, 120hrs	Per table in below
5	High Temp & High Humidity Storage	Ta=+60°C, 90% RH 120 hours	Per table in below (polarizer discoloration is excluded)
6	Thermal Shock (Non-operation)	-30°C 30 min~+80°C 30 min, Change time:5min, 100 Cycles	Per table in below
7	ESD (Operation)	C=150pF, R=330Ω · 5points/panel Air:±8KV, 5times; Contact:±4KV, 5 times;	Per table in below
8	Vibration (Non-operation)	Frequency range:10~55Hz, Stroke:1.5mm Sweep:10Hz~55Hz~10Hz 2 hours for each direction of X.Y.Z.	Per table in below
9	Shock (Non-operation)	60G 6ms, ±X,±Y,±Z 3times, for each direction	Per table in below
10	Package Drop Test	Height:80 cm, 1 corner, 3 edges, 6 surfaces	Per table in below

INSPECTION	CRITERION(after test)
Appearance	No Crack on the FPC, on the LCD Panel
Alignment of LCD Panel	No Bubbles in the LCD Panel No other Defects of Alignment in Active area
Electrical current	Within device specifications
Function / Display	No Broken Circuit, No Short Circuit or No Black line No Other Defects of Display

11. Precautions for Use of LCD Modules

11.1 Safety

The liquid crystal in the LCD is poisonous. Do not put it in your mouth. If the liquid crystal touches your skin or clothes, wash it off immediately using soap and water.

11.2 Handling

A. The LCD and touch panel is made of plate glass. Do not subject the panel to mechanical shock or to excessive force on its surface.

B. Do not handle the product by holding the flexible pattern portion in order to assure the reliability

C. Transparency is an important factor for the touch panel. Please wear clear finger sacks, gloves and mask to protect the touch panel from finger print or stain and also hold the portion outside the view area when handling the touch panel.

D. Provide a space so that the panel does not come into contact with other components.

E. To protect the product from external force, put a covering lens (acrylic board or similar board) and keep an appropriate gap between them.

F. Transparent electrodes may be disconnected if the panel is used under environmental conditions where dew condensation occurs.

G. Property of semiconductor devices may be affected when they are exposed to light, possibly resulting in IC malfunctions.

H. To prevent such IC malfunctions, your design and mounting layout shall be done in the way that the IC is not exposed to light in actual use.

11.3 Static Electricity

A. Ground soldering iron tips, tools and testers when they are in operation.

B. Ground your body when handling the products.

C. Power on the LCD module before applying the voltage to the input terminals.

D. Do not apply voltage which exceeds the absolute maximum rating.

E. Store the products in an anti-electrostatic bag or container.

11.4 Storage

A. Store the products in a dark place at $+25^{\circ}\text{C} \pm 10^{\circ}\text{C}$ with low humidity (40% RH to 60% RH). Don't expose to sunlight or fluorescent light.

B. Storage in a clean environment, free from dust, active gas, and solvent.

11.5 Cleaning

A. Do not wipe the touch panel with dry cloth, as it may cause scratch.

B. Wipe off the stain on the product by using soft cloth moistened with ethanol. Do not allow ethanol to get in between the upper film and the bottom glass. It may cause peeling issue or defective operation. Do not use any organic solvent or detergent other than ethanol.

11.6 Cautions for installing and assembling

Bezel edge must be positioned in the area between the Active area and View area. The bezel may press the touch screen and cause activation if the edge touches the active area. A gap of approximately 0.5mm is needed between the bezel and the top electrode. It may cause unexpected activation if the gap is too narrow. There is a tolerance of 0.2 to 0.3mm for the outside dimensions of the touch panel and tail. A gap must be made to absorb the tolerance in the case and connector.

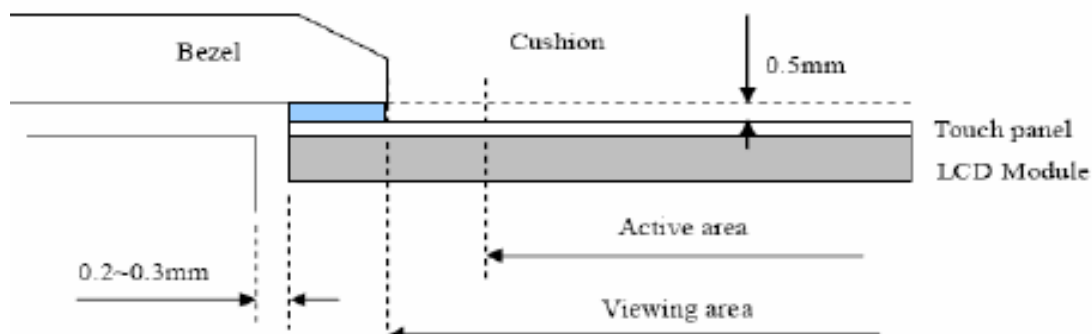

X-ON Electronics

Largest Supplier of Electrical and Electronic Components

Click to view similar products for [TFT Displays & Accessories](#) category:

Click to view products by [Microtips](#) manufacturer:

Other Similar products are found below :

[F3ET2-005-150](#) [HDA430T-3G1H](#) [NL6448BC20-21D](#) [NB7W-KBA04](#) [NB-ATT01](#) [NB5Q-ATT01](#) [NB5Q-KBA04](#) [NB-CN001](#) [OAI-80038AA-2008-A](#) [315-U004B15300](#) [UMSH-8596MD-34T \(REV D\)](#) [TCG121WXLRXVNNANX35](#) [EIC-LCD-1080P](#) [T-55619GD065J-LW-ABN](#) [TCG104SVLPEANN-AN30](#) [NL6448BC33-70](#) [NL6448BC20-30D](#) [NL10276BC16-06](#) [NL192108AC10-01D](#) [NL12880BC20-05BD](#) [NL8060BC26-35BA](#) [NL8060BC31-50F](#) [TM070DDHG03-40](#) [NL10276AC30-42C](#) [PTPW16-070WV1S02](#) [PTPW17-070WV1S02](#) [PTPW16-084SV1S02](#) [MTD0300ECP06DF-1](#) [DEM 320240T VMX-PW-N \(A-TOUCH\)](#) [DEM 480128B TMH-PW-N \(A-TOUCH\)](#) [DEM 480272P VMX-PW-N \(C-TOUCH\)](#) [DEM 480272Q VMX-PW-N \(A-TOUCH\)](#) [DEM 480272Q VMX-PW-N \(C-TOUCH\)](#) [DEM 640480E TMH-PW-N \(A-TOUCH\)](#) [DEM 800480K1 TMH-PW-N \(A-TOUCH\)](#) [DEM 800480K1 TMH-PW-N \(C-TOUCH\)](#) [DEM 800480K2 TMH-PW-N \(A-TOUCH\)](#) [DEM 800480K3 TMH-PW-N \(C-TOUCH\)](#) [DEM 800480K4 TMH-PW-N \(A-TOUCH\)](#) [DEM 800480K4 TMH-PW-N \(C-TOUCH\)](#) [4DLCD-35480320-CTP-IPS](#) [4DLCD-35480320-IPS](#) [4DLCD-35480320-RTP-IPS](#) [4DLCD-50800480-CTP-IPS](#) [RFA6400E-AWH-DNG](#) [RFA6400E-AWH-MNN](#) [RFE430V-AZW-DNS](#) [RFF70VA2-1IW-DHS](#) [RFH700A8-AYH-MNN](#) [RFK101VF-1YH-LHG](#)