

The logo for Microtips Technology features a stylized graphic of vertical bars in red, green, and blue on the left, followed by the word "Microtips" in a large, bold, black serif font. Below this, a thick horizontal line separates the word "TECHNOLOGY" from the rest of the page, with the letters in a smaller, bold, black serif font.

Microtips

TECHNOLOGY

EPD Module User Manual
MT-DEPG0370RWU253F4

Approved By	

Tel: 1 (888) 499-8477

Fax: (407) 273-0771

E-mail: mtusainfo@microtipsusa.com

Web: www.microtipsusa.com

Specification for 3.7 inch EPD

Model NO. : MT-DEPG0370RWU253F4

MT's Confirmation:

Prepared by	Checked by	Approved by

Customer approval:

Customer	Approved by	Date

Revision History

Version	Content	Date	Producer
1.0	New release	2020-6-5	

CONTENTS

1 Over View	6
2 Features	6
3 Mechanical Specification	6
4 Mechanical Drawing of EPD Module.....	7
5 Input/output Pin Assignment	8
6 Electrical Characteristics	9
6.1 Absolute Maximum Rating	9
6.2 Panel DC Characteristics.....	10
6.3 Panel AC Characteristics	11
6.3.1 MCU Interface Selection.....	11
6.3.2 MCU Serial Interface (4-wire SPI).....	11
6.3.3 MCU Serial Interface (3-wire SPI)	12
6.3.4 Interface Timing.....	12
7 Command Table.....	14
8 Optical Specification.....	35
9 Handling, Safety, and Environment Requirements.....	35
10 Reliability Test	36
11 Block Diagram	37

12 Typical Application Circuit with SPI Interface.....	38
13 Typical Operating Sequence.....	39
13.1 OTP Operation Flow.....	39
13.2 OTP Operation Reference Program Code.....	40
14 Part Number Definition	41
15 Inspection condition.....	41
15.1 Environment.....	41
15.2 Illuminance	41
15.3 Inspect method.....	41
15.4 Display area	42
15.5 Inspection standard.....	42
15.5.1 Electric inspection standard.....	42
15.5.2 Appearance inspection standard.....	43
16 Packaging.....	45

1. Over View

MT-DEPG0370RWU253F4 is an Active Matrix Electrophoretic Display (AM EPD), with interface and a reference system design. The display is capable to display images at 1-bit white, black and red full display capabilities. The 3.7inch active area contains 416×240 pixels. The module is a TFT-array driving electrophoresis display, with integrated circuits including gate driver, source driver, MCU interface, timing controller, oscillator, DC-DC, SRAM, LUT, VCOM. Module can be used in portable electronic devices, such as Electronic Shelf Label (ESL) System.

2. Features

- ◆ 416×240 pixels display
- ◆ High contrast High reflectance
- ◆ Ultra wide viewing angle Ultra low power consumption
- ◆ Pure reflective mode
- ◆ Bi-stable display
- ◆ Commercial temperature range
- ◆ Landscape portrait modes
- ◆ Hard-coat antiglare display surface
- ◆ Ultra Low current deep sleep mode
- ◆ On chip display RAM
- ◆ Waveform can stored in On-chip OTP or written by MCU
- ◆ Serial peripheral interface available
- ◆ On-chip oscillator
- ◆ On-chip booster and regulator control for generating VCOM, Gate and Source driving voltage
- ◆ I²C signal master interface to read external temperature sensor
- ◆ Built-in temperature sensor

3. Mechanical Specification

Parameter	Specifications	Unit	Remark
Screen Size	3.7	Inch	
Display Resolution	240(H)×416(V)	Pixel	DPI:130
Active Area	47.04×81.54	mm	
Pixel Pitch	0.196×0.196	mm	
Pixel Configuration	Square		
Outline Dimension	53(H)×92.99 (V) ×1.0(D)	mm	
Weight	8.88±0.5	g	

4. Mechanical Drawing of EPD Module

<p>Confirmation:</p>	<table border="1" style="width: 100%; border-collapse: collapse;"> <thead> <tr> <th>DATE</th> <th>REV.</th> <th>MODIFICATION</th> </tr> </thead> <tbody> <tr> <td>2020-04-28</td> <td>A</td> <td>FIRST ISSUE</td> </tr> <tr> <td>2020-05-08</td> <td>B</td> <td>MODIFY FPC</td> </tr> </tbody> </table>	DATE	REV.	MODIFICATION	2020-04-28	A	FIRST ISSUE	2020-05-08	B	MODIFY FPC
DATE	REV.	MODIFICATION								
2020-04-28	A	FIRST ISSUE								
2020-05-08	B	MODIFY FPC								

FRONT VIEW

SIDE VIEW

BACK VIEW

NOTE

- 1 DISPLAY MODULE 3.7" ARRAY FOR EPD
- 2 DRIVER IC:UC8253
- 3 RESOLUTION:416gateX240source
- 4 PIXEL SIZE:0.196mmX0.196mm

TOLERANCES UNMARKED	TITLE: EPD	PROJECT: DEPG0370__U253F4	REV.: B	DATE: 20.05.08	CUST. P/N#
ANGLES±5° .X=±0.4mm .XX=±0.20mm .XXX=±0.20mm	DWN. NN ZHAO	CHK. CC ZHENG	APPR. SY ZHAO	UNIT: mm	3RD ANGLE: 1/1

5. Input/output Pin Assignment

No.	Name	I/O	Description	Remark
1	NC		Do not connect with other NC pins	Keep Open
2	GDR	O	N-Channel MOSFET Gate Drive Control	
3	RESE	I	Current Sense Input for the Control Loop	
4	NC	NC	Do not connect with other NC pins	Keep Open
5	VSH2 (RED)	C	Positive Source driving voltage	
6	TSCL	O	I2C Interface to digital temperature sensor Clock pin	
7	TSDA	I/O	I2C Interface to digital temperature sensor Data pin	
8	BS1	I	Bus Interface selection pin	Note 5-5
9	BUSY	O	Busy state output pin	Note 5-4
10	RES#	I	Reset signal input. Active Low.	Note 5-3
11	D/C#	I	Data /Command control pin	Note 5-2
12	CS#	I	Chip select input pin	Note 5-1
13	SCL	I	Serial Clock pin (SPI)	
14	SDA	I/O	Serial Data pin (SPI)	
15	VDDIO	P	Power Supply for interface logic pins It should be connected with VCI	
16	VCI	P	Power Supply for the chip	
17	VSS	P	Ground	
18	VDD	C	Core logic power pin VDD can be regulated internally from VCI. A capacitor should be connected between VDD and VSS	
19	VPP	P	FOR TEST	Keep Open
20	VSH1	C	Positive Source driving voltage	
21	VGH	C	Power Supply pin for Positive Gate driving voltage and VSH1	
22	VSL	C	Negative Source driving voltage	
23	VGL	C	Power Supply pin for Negative Gate driving voltage VCOM and VSL	
24	VCOM	C	VCOM driving voltage	

I = Input Pin, O =Output Pin, I/O = Bi-directional Pin (Input/output), P = Power Pin, C = Capacitor Pin

Note 5-1: This pin (CS#) is the chip select input connecting to the MCU. The chip is enabled for MCU communication only when CS# is pulled LOW.

Note 5-2: This pin is (D/C#) Data/Command control pin connecting to the MCU in 4-wire SPI mode. When the pin is pulled HIGH, the data at SDA will be interpreted as data. When the pin is pulled LOW, the data at SDA will be interpreted as command.

Note 5-3: This pin (RES#) is reset signal input. The Reset is active low.

Note 5-4: This pin is Busy state output pin. When Busy is low, the operation of chip should not be interrupted, command should not be sent. The chip would put Busy pin low when -Outputting display waveform -Communicating with digital temperature sensor

Note 5-5: Bus interface selection pin

BS1 State	MCU Interface
L	4-lines serial peripheral interface(SPI) - 8 bits SPI
H	3- lines serial peripheral interface(SPI) - 9 bits SPI

6. Electrical Characteristics

6.1 Absolute Maximum Rating

Parameter	Symbol	Rating	Unit
Logic supply voltage	VCI	-0.3 to +6.0	V
Logic Input voltage	VIN	-0.3 to VCI +0.3	V
Operating Temp range	TOPR	0 to +40	°C.
Storage Temp range	TSTG	-25 to+40	°C.
Optimal Storage Temp	TSTGo	23±3	°C.
Optimal Storage Humidity	HSTGo	55±10	%RH

Note:

Maximum ratings are those values beyond which damages to the device may occur. Functional operation should be restricted to the limits in the Panel DC Characteristics tables.

6.2 Panel DC Characteristics

The following specifications apply for: VSS=0V, VCI=3.3V, TOPR =23°C.

Parameter	Symbol	Condition	Applicable pin	Min.	Typ.	Max.	Unit
Single ground	VSS	-		-	0	-	V
Logic supply voltage	VCI	-	VCI	2.3	3.3	3.6	V
Supply voltage	VDD		VDD	2.3	3.3	3.6	V
HIGH Level input voltage	VIH	Digital input pins	-	0.7VCI	--	VCI	V
LOW Level input voltage	VIL	Digital input pins	-	0	--	0.3VCI	V
HIGH Level output voltage	VOH	Digital input pins, IOH=400UA	-	VCI-0.4	--	--	V
LOW Level Output voltage	VOL	Digital input pins, IOL=-400UA	-	0	--	0.4	V
Typical power	PTYP	VCI =3.3V	-	-	18.15	-	mW
Deep sleep mode	PSTPY	VCI =3.3V	-	-	0.003	-	mW
Typical operating current	Iopr_VCI	VCI =3.3V	-	-	5.5	-	mA
Image update time	-	23 °C	-	-	14	-	sec
Sleep mode current	Idslp_VCI	DC/DC off No clock No input load Ram data retain	-	-	20		uA
Deep sleep mode current	Idslp_VCI	DC/DC off No clock No input load Ram data not retain	-	-	1	5	uA

Notes: 1. The typical power is measured with following transition from horizontal 2 scale pattern to vertical 2 scale pattern.

6.3 Panel AC Characteristics

6.3.1 MCU Interface Selection

The pin assignment at different interface mode is summarized in Table 6-3-1. Different MCU mode can be set by hardware selection on BS1 pins. The display panel only supports 4-wire SPI or 3-wire SPI interface mode.

Pin Name	Data/Command Interface		Control Signal		
	SDA	SCL	CS#	D/C#	RES#
Bus interface	SDA	SCL	CS#	D/C#	RES#
BS1=L 4-wire SPI	SDA	SCL	CS#	D/C#	RES#
BS1=H 3-wire SPI	SDA	SCL	CS#	L	RES#

Table 6-3-1: MCU interface assignment under different bus interface mode

6.3.2 MCU Serial Interface (4-wire SPI)

The serial interface consists of serial clock SCL, serial data SDA, D/C#, CS#. This interface supports Write mode and Read mode.

Function	CS#	D/C#	SCL
Write command	L	L	↑
Write data	L	H	↑

Table 6-3-2: Control pins of 4-wire Serial Peripheral interface

Note: ↑ stands for rising edge of signal

Figure 6-3-1: 4-wire SPI mode

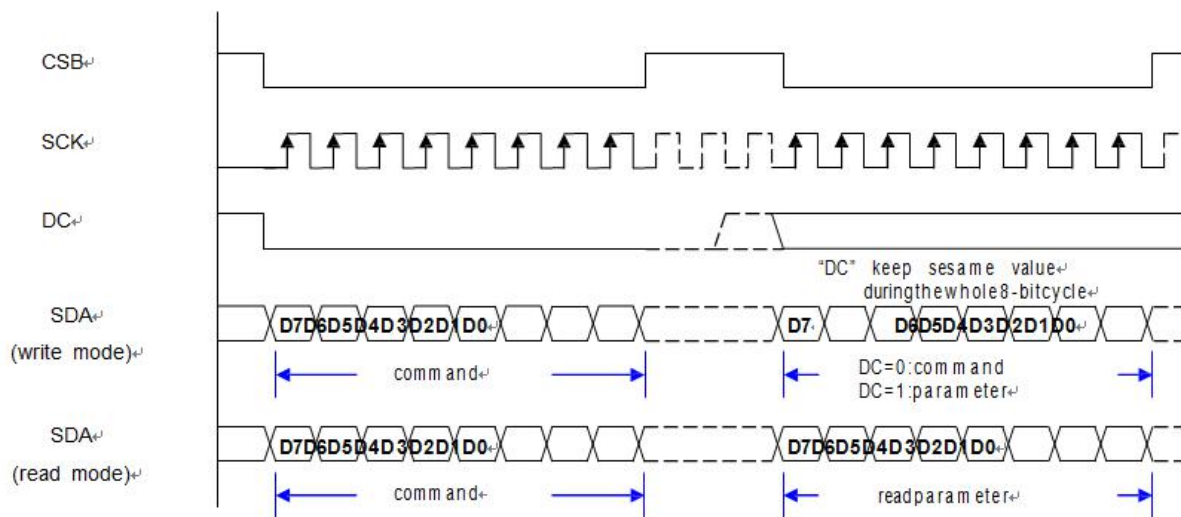

6.3.3 MCU Serial Interface (3-wire SPI)

Function	CS#	D/C#	SCL
Write command	L	Tie	↑
Write data	L	Tie	↑

Table 6-3-3: Control pins of 4-wire Serial Peripheral interface

Note: ↑ stands for rising edge of signal

Figure 6-3-2: 3-wire SPI mode

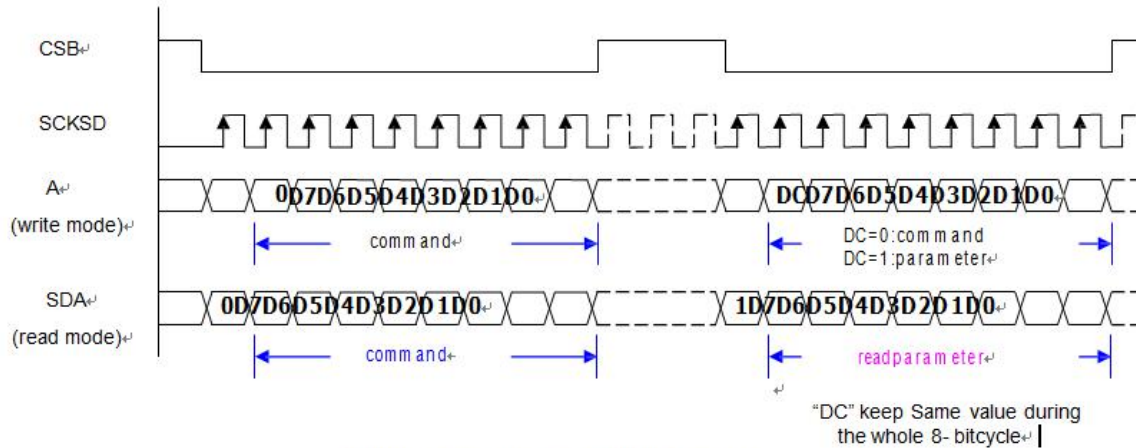

Figure : 3-wire SPI Typical Waveform –BS=1

6.3.4 Interface Timing

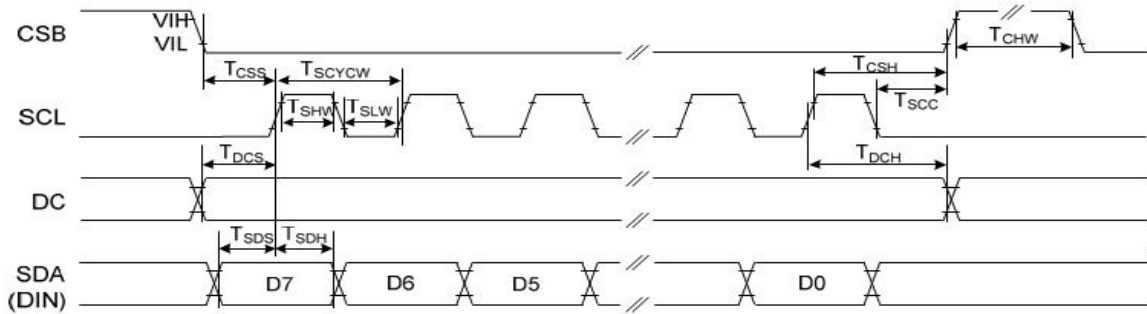

Figure: 4-wire Serial Interface Characteristics (Writemode)

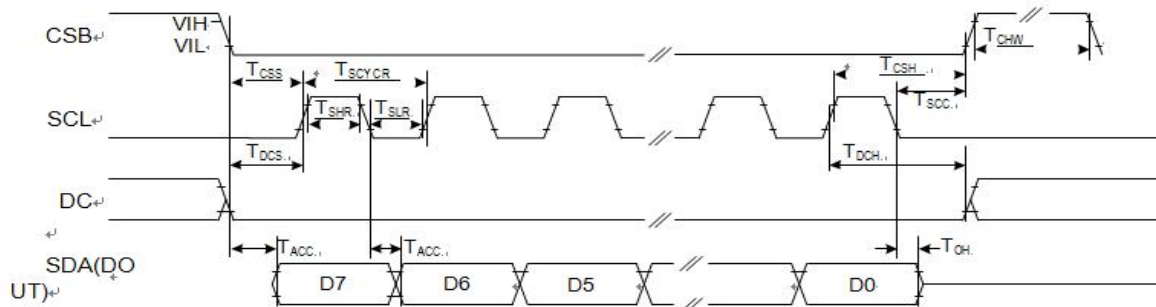

Figure: 4-wire Serial Interface Characteristics (Readmode)

Serial Interface Timing Characteristics

Symbol	Signal /Parameter	Conditions	Min.	Typ.	Max.	Unit
T _{CSS}	CSB	Chip select setup time	60			ns
T _{CSH}		Chip select hold time	65			ns
T _{SCC}		Chip select setup time	20			ns
T _{CHW}		Chip select setup time	40			ns
T _{SCYCW}	SCL	Serial clock cycle(Write)	100			ns
T _{SHW}		SCL "H" pulse width(Write)	35			ns
T _{SLW}		SCL "L" pulse width(Write)	35			ns
T _{SCYCR}		Serial clock cycle(Read)	150			ns
T _{SHR}		SCL "H" pulse width(Read)	60			ns
T _{SLR}		SCL "L" pulse width(Read)	60			ns
T _{DCS}	DC	DC setup time	30			ns
T _{DCH}		DC hold time	30			ns
T _{SDS}	SDA (DIN)	Data setup time	30			ns
T _{SDH}		Data hold time	30			ns
T _{ACC}	SDA (DOUT)	Access time			10	ns
T _{OH}		Output disable time	15			ns

7. Command Table

(1) PANEL SETTING (PSR) (REGISTER: R00H)

Action	W/R	C/D	D7	D6	D5	D4	D3	D2	D1	D0	
Setting the panel	0	0	0	0	0	0	0	0	0	0	00H
	0	1	RES1	RES0	REG	KW/R	UD	SHL	SHD_N	RST_N	0FH
	0	1	-	-	-	VCMZ	TS_AUTO	TIEG	NORG	VCM_LUTZ	8DH

RES[1:0]: Display Resolution setting (source x gate)

00b: 240x120 (Default) Active gate channels: G0 ~ G239. Active source channels: S0 ~ S119.
01b: 320x160 Active gate channels: G0 ~ G319. Active source channels: S0 ~ S159.
10b: 400x200 Active gate channels: G0 ~ G399. Active source channels: S0 ~ S199.
11b: 480x240 Active gate channels: G0 ~ G479. Active source channels: S0 ~ S239.

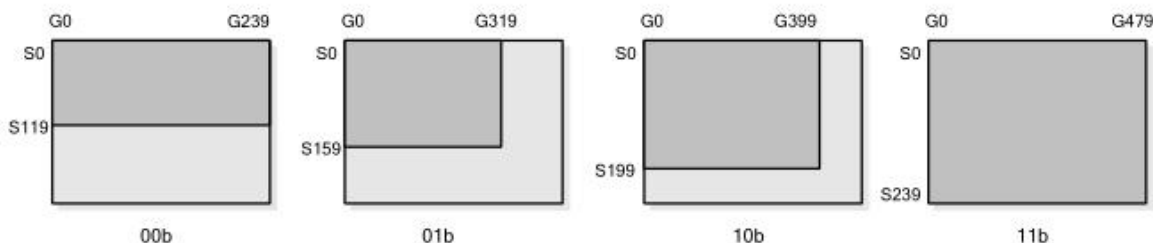

REG: LUT selection

0: LUT from OTP. (Default)
1: LUT from register.

KW/R: Black / White / Red

0: Pixel with Black/White/Red, KWR mode. (Default)
1: Pixel with Black/White, KW mode.

UD: Gate Scan Direction

0: Scan down. First line to Last line: Gn-1 → Gn-2 → Gn-3 → ... → G0
1: Scan up. (Default) First line to Last line: G0 → G1 → G2 → ... → Gn-1

SHL: Source Shift Direction

0: Shift left. First data to Last data: Sn-1 → Sn-2 → Sn-3 → ... → S0
1: Shift right. (Default) First data to Last data: S0 → S1 → S2 → ... → Sn-1

SHD_N: Booster Switch

0: Booster OFF
1: Booster ON (Default)

When SHD_N becomes LOW, charge pump will be turned OFF, register and SRAM data will keep until VDD OFF. And Source/Gate/Border/VCOM will be released to floating.

RST_N: Soft Reset

0: Reset. Booster OFF, Register data are set to their default values, all drivers will be reset, and all functions will be disabled. Source/Gate/Border/VCOM will be released to floating. After soft reset is transmitted, the internal operation needs at least 50uS to execute. During this period of time, the BUSY_N pin keeps low and any command will be ignored.

1: No effect (Default).

- VCMZ:** VCOM Hi-Z state function
0: No effect (Default)
1 : VCOM is always floating
- TS_AUTO:** Temperature sensor will be activated automatically one time.
0: No effect (Default)
1: Before enabling booster, Temperature Sensor will be activated automatically one time.
- TIEG:** VGL state function
0: No effect (Default)
1 : After power off booster, VGL will be tied to GND.
- NORG:** VCOM state during refreshing display
0: No effect (Default)
1: Expect refreshing display, VCOM is tied to GND.
- VC_LUTZ:** VCOM state during refreshing display
0: No effect (Default)
1: After refreshing display, the output of VCOM is set to floating automatically.

Note: Priority of Vcom setting: VCMZ > EOPT > NORG > VC_LUTZ

(2) POWER SETTING (PWR) (R01H)

Action	W/R	C/D	D7	D6	D5	D4	D3	D2	D1	D0	
Selecting Internal/External Power	0	0	0	0	0	0	0	0	0	1	01H
	0	1	-	-	-	BD_EN	-	-	VDS_EN	VDG_EN	03H
	0	1	-	-	-	VCOM_SLEW	VGHL_LV[3:0]				10H
	0	1	-	-	VSH[5:0]					3FH	
	0	1	-	-	VSL[5:0]					3FH	
	0	1	OPTEN	VDHR[6:0]							0DH

BD_EN: Border LDO enable
0 : Border LDO disable (Default)
 Border level selection: 00b: VCOM 01b: VDH 10b: VDL 11b: VDHR
1 : Border LDO enable
 Border level selection: 00b: VCOM 01b: VBH(VCOM-VDL) 10b: VBL(VCOM-VDH) 11b: VDHR

VDS_EN: Source power selection
 0 : External source power from VSH/VSL/VDHR pins
1 : Internal DC/DC function for generating VSH/VSL/VDHR. (Default)

VDG_EN: Gate power selection
 0 : External gate power from VGH/VGL pins
1 : Internal DC/DC function for generating VGH/VGL. (Default)

VCOM_SLEW: VCOM slew rate selection for voltage transition. The value is fixed at 1.
VGHL_LV[3:0]: VGH / VGL Voltage Level selection.

VGHL_LV	VGHL Voltage Level
0000 (Default)	VGH=20V, VGL= -20V
0001	VGH=19V, VGL= -19V
0010	VGH=18V, VGL= -18V
0011	VGH=17V, VGL= -17V
0100	VGH=16V, VGL= -16V
0101	VGH=15V, VGL= -15V
0110	VGH=14V, VGL= -14V
0111	VGH=13V, VGL= -13V
1000	VGH=12V, VGL= -12V
1001	VGH=11V, VGL= -11V
1010	VGH=10V, VGL= -10V

VSH[5:0]: Internal VSH power selection for B/W pixel. (Default value: 11 1111b)

VSH	Voltage	VSH	Voltage	VSH	Voltage	VSH	Voltage
00 0000	2.4 V	01 0000	5.6 V	10 0000	8.8 V	11 0000	12.0 V
00 0001	2.6 V	01 0001	5.8 V	10 0001	9.0 V	11 0001	12.2 V
00 0010	2.8 V	01 0010	6.0 V	10 0010	9.2 V	11 0010	12.4 V
00 0011	3.0 V	01 0011	6.2 V	10 0011	9.4 V	11 0011	12.6 V
00 0100	3.2 V	01 0100	6.4 V	10 0100	9.6 V	11 0100	12.8 V
00 0101	3.4 V	01 0101	6.6 V	10 0101	9.8 V	11 0101	13.0 V
00 0110	3.6 V	01 0110	6.8 V	10 0110	10.0V	11 0110	13.2 V
00 0111	3.8 V	01 0111	7.0 V	10 0111	10.2 V	11 0111	13.4 V
00 1000	4.0 V	01 1000	7.2 V	10 1000	10.4 V	11 1000	13.6 V
00 1001	4.2 V	01 1001	7.4 V	10 1001	10.6 V	11 1001	13.8 V
00 1010	4.4 V	01 1010	7.6 V	10 1010	10.8 V	11 1010	14.0 V
00 1011	4.6 V	01 1011	7.8 V	10 1011	11.0 V	11 1011	14.2 V
00 1100	4.8 V	01 1100	8.0 V	10 1100	11.2 V	11 1100	14.4 V
00 1101	5.0 V	01 1101	8.2V	10 1101	11.4 V	11 1101	14.6 V
00 1110	5.2 V	01 1110	8.4 V	10 1110	11.6 V	11 1110	14.8 V
00 1111	5.4 V	01 1111	8.6 V	10 1111	11.8 V	11 1111	15.0 V

VSL[5:0]: Internal VSL power selection for B/W pixel. (Default value: 11 1111b)

VSL	Voltage	VSL	Voltage	VSL	Voltage	VSL	Voltage
-----	---------	-----	---------	-----	---------	-----	---------

00 0000	-2.4 V	01 0000	-5.6 V	10 0000	-8.8 V	11 0000	-12.0 V
00 0001	-2.6 V	01 0001	-5.8 V	10 0001	-9.0 V	11 0001	-12.2 V
00 0010	-2.8 V	01 0010	-6.0 V	10 0010	-9.2 V	11 0010	-12.4 V
00 0011	-3.0 V	01 0011	-6.2 V	10 0011	-9.4 V	11 0011	-12.6 V
00 0100	-3.2 V	01 0100	-6.4 V	10 0100	-9.6 V	11 0100	-12.8 V
00 0101	-3.4 V	01 0101	-6.6 V	10 0101	-9.8 V	11 0101	-13.0 V
00 0110	-3.6 V	01 0110	-6.8 V	10 0110	-10.0V	11 0110	-13.2 V
00 0111	-3.8 V	01 0111	-7.0 V	10 0111	-10.2 V	11 0111	-13.4 V
00 1000	-4.0 V	01 1000	-7.2 V	10 1000	-10.4 V	11 1000	-13.6 V
00 1001	-4.2 V	01 1001	-7.4 V	10 1001	-10.6 V	11 1001	-13.8 V
00 1010	-4.4 V	01 1010	-7.6 V	10 1010	-10.8 V	11 1010	-14.0 V
00 1011	-4.6 V	01 1011	-7.8 V	10 1011	-11.0 V	11 1011	-14.2 V
00 1100	-4.8 V	01 1100	-8.0 V	10 1100	-11.2 V	11 1100	-14.4 V
00 1101	-5.0 V	01 1101	-8.2 V	10 1101	-11.4 V	11 1101	-14.6 V
00 1110	-5.2 V	01 1110	-8.4 V	10 1110	-11.6 V	11 1110	-14.8 V
00 1111	-5.4 V	01 1111	-8.6 V	10 1111	-11.8 V	11 1111	-15.0 V

VDHR[5:0]: Internal VDHR power selection for Red pixel. (Default value: **001101b**)

VDHR	Voltage	VDHR	Voltage	VDHR	Voltage	VDHR	Voltage
00 0000	2.4 V	01 0000	5.6 V	10 0000	8.8 V	11 0000	12.0 V
00 0001	2.6 V	01 0001	5.8 V	10 0001	9.0 V	11 0001	12.2 V
00 0010	2.8 V	01 0010	6.0 V	10 0010	9.2 V	11 0010	12.4 V
00 0011	3.0 V	01 0011	6.2 V	10 0011	9.4 V	11 0011	12.6 V
00 0100	3.2 V	01 0100	6.4 V	10 0100	9.6 V	11 0100	12.8 V
00 0101	3.4 V	01 0101	6.6 V	10 0101	9.8 V	11 0101	13.0 V
00 0110	3.6 V	01 0110	6.8 V	10 0110	10.0 V	11 0110	13.2 V
00 0111	3.8 V	01 0111	7.0 V	10 0111	10.2 V	11 0111	13.4 V
00 1000	4.0 V	01 1000	7.2 V	10 1000	10.4 V	11 1000	13.6 V
00 1001	4.2 V	01 1001	7.4 V	10 1001	10.6 V	11 1001	13.8 V
00 1010	4.4 V	01 1010	7.6 V	10 1010	10.8 V	11 1010	14.0 V
00 1011	4.6 V	01 1011	7.8 V	10 1011	11.0 V	11 1011	14.2 V
00 1100	4.8 V	01 1100	8.0 V	10 1100	11.2 V	11 1100	14.4 V
00 1101	5.0 V	01 1101	8.2 V	10 1101	11.4 V	11 1101	14.6 V
00 1110	5.2 V	01 1110	8.4 V	10 1110	11.6 V	11 1110	14.8 V
00 1111	5.4 V	01 1111	8.6 V	10 1111	11.8 V	11 1111	15.0 V

OPTEN: 1 enable step-0.1V voltage selection.

VDHR	Voltage	VDHR	Voltage	VDHR	Voltage	VDHR	Voltage
1000 0000	2.4 V	1010 0000	5.6 V	1100 0000	8.8 V	1110 0000	12 V
1000 0001	2.5 V	1010 0001	5.7 V	1100 0001	8.9 V	1110 0001	12.1 V
1000 0010	2.6 V	1010 0010	5.8 V	1100 0010	9.0 V	1110 0010	12.2 V
1000 0011	2.7 V	1010 0011	5.9 V	1100 0011	9.1 V	1110 0011	12.3 V
1000 0100	2.8 V	1010 0100	6.0 V	1100 0100	9.2 V	1110 0100	12.4 V
1000 0101	2.9 V	1010 0101	6.1 V	1100 0101	9.3 V	1110 0101	12.5 V
1000 0110	3.0 V	1010 0110	6.2 V	1100 0110	9.4 V	1110 0110	12.6 V
1000 0111	3.1 V	1010 0111	6.3 V	1100 0111	9.5 V	1110 0111	12.7 V
1000 1000	3.2 V	1010 1000	6.4 V	1100 1000	9.6 V	1110 1000	12.8 V
1000 1001	3.3 V	10101001	6.5 V	1100 1001	9.7 V	1110 1001	12.9 V
1000 1010	3.4 V	1010 1010	6.6 V	1100 1010	9.8 V	1110 1010	13.0 V
1000 1011	3.5 V	1010 1011	6.7 V	1100 1011	9.9 V	1110 1011	13.1 V
1000 1100	3.6 V	1010 1100	6.8 V	1100 1100	10.0 V	1110 1100	13.2 V
1000 1101	3.7 V	1010 1101	6.9 V	1100 1101	10.1 V	1110 1101	13.3 V
1000 1110	3.8 V	1010 1110	7.0 V	1100 1110	10.2 V	1110 1110	13.4 V
1000 1111	3.9 V	1010 1111	7.1 V	1100 1111	10.3 V	1110 1111	13.5 V
1001 0000	4.0 V	1011 0000	7.2 V	1101 0000	10.4 V	1111 0000	13.6 V
1001 0001	4.1 V	1011 0001	7.3 V	1101 0001	10.5 V	1111 0001	13.7 V
1001 0010	4.2 V	1011 0010	7.4 V	1101 0010	10.6 V	1111 0010	13.8 V
1001 0011	4.3 V	1011 0011	7.5 V	1101 0011	10.7 V	1111 0011	13.9 V
1001 0100	4.4 V	1011 0100	7.6 V	1101 0100	10.8 V	1111 0100	14.0 V
1001 0101	4.5 V	1011 0101	7.7 V	1101 0101	10.9 V	1111 0101	14.1 V
1001 0110	4.6 V	1011 0110	7.8 V	1101 0110	11.0 V	1111 0110	14.2 V
1001 0111	4.7 V	1011 0111	7.9 V	1101 0111	11.1 V	1111 0111	14.3 V
1001 1000	4.8 V	1011 1000	8.0 V	1101 1000	11.2 V	1111 1000	14.4 V
1001 1001	4.9 V	1011 1001	8.1 V	1101 1001	11.3 V	1111 1001	14.5 V
1001 1010	5.0 V	1011 1010	8.2 V	1101 1010	11.4 V	1111 1010	14.6 V
1001 1011	5.1 V	1011 1011	8.3 V	1101 1011	11.5 V	1111 1011	14.7 V
1001 1100	5.2 V	1011 1100	8.4 V	11011100	11.6 V	1111 1100	14.8 V
1001 1101	5.3 V	1011 1101	8.5 V	1101 1101	11.7 V	1111 1101	14.9 V
1001 1110	5.4 V	1011 1110	8.6 V	1101 1110	11.8 V	1111 1110	15.0 V
1001 1111	5.5 V	1011 1111	8.7 V	1101 1111	11.9 V		

(3) POWER OFF (POF) (R02H)

Action	W/R	C/D	D7	D6	D5	D4	D3	D2	D1	D0
Turning OFF the power	0	0	0	0	0	0	0	0	1	0

After the Power OFF command, the driver will be powered OFF. Refer to the POWER MANAGEMENT section for the sequence.

This command will turn off booster, controller, source driver, gate driver, VCOM, and temperature sensor, but register data will be kept until VDD turned OFF or Deep Sleep Mode. Source/Gate/Border/VCOM will be released to floating.

(4) POWER OFF SEQUENCE SETTING (PFS) (R03H)

Action	W/R	C/D	D7	D6	D5	D4	D3	D2	D1	D0
Setting Power OFF sequence	0	0	0	0	0	0	0	0	1	1
	0	1	-	-	T_VDS_OFF[1:0]	-	-	-	-	-

T_VDS_OFF[1:0]: Source to gate power off interval time.

00b: 1 frame (Default) 01b: 2 frames 10b: 3 frames 11b: 4 frame

(5) POWER ON (PON) (REGISTER: R04H)

Action	W/R	C/D	D7	D6	D5	D4	D3	D2	D1	D0
Turning ON the power	0	0	0	0	0	0	0	1	0	0

After the Power ON command, the driver will be powered ON. Refer to the POWER MANAGEMENT section for the sequence.

This command will turn on booster, controller, regulators, and temperature sensor will be activated for one-time sensing before enabling booster. When all voltages are ready, the BUSY_N signal will return to high.

(6) POWER ON MEASURE (PMES) (R05H)

Action	W/R	C/D	D7	D6	D5	D4	D3	D2	D1	D0
	0	0	0	0	0	0	0	1	0	1

This command enables the internal bandgap, which will be cleared by the next POF.

(7) BOOSTER SOFT START (BTST) (R06H)

Action	W/R	C/D	D7	D6	D5	D4	D3	D2	D1	D0
Starting data transmission	0	0	0	0	0	0	0	1	1	0
	0	1	BT_PHA7	BT_PHA6	BT_PHA5	BT_PHA4	BT_PHA3	BT_PHA2	BT_PHA1	BT_PHA0
	0	1	BT_PHB7	BT_PHB6	BT_PHB5	BT_PHB4	BT_PHB3	BT_PHB2	BT_PHB1	BT_PHB0
	0	1	-	-	BT_PHC5	BT_PHC4	BT_PHC3	BT_PHC2	BT_PHC1	BT_PHC0

BTPHA[7:6]: Soft start period of phase A.

00b: 10mS 01b: 20mS 10b: 30mS 11b: 40mS

BTPHA[5:3]: Driving strength of phase A

000b: strength 1 001b: strength 2 **010b: strength 3** 011b: strength 4
 100b: strength 5 101b: strength 6 110b: strength 7 111b: strength 8 (strongest)

BTPHA[2:0]: Minimum OFF time setting of GDR in phase A

000b: 0.27uS 001b: 0.34uS 010b: 0.40uS 011b: 0.54uS
 100b: 0.80uS 101b: 1.54uS 110b: 3.34uS **111b: 6.58uS**

BTPHB[7:6]: Soft start period of phase B.

00b: 10mS 01b: 20mS 10b: 30mS 11b: 40mS

BTPHB[5:3]: Driving strength of phase B

000b: strength 1 001b: strength 2 **010b: strength 3** 011b: strength 4
 100b: strength 5 101b: strength 6 110b: strength 7 111b: strength 8 (strongest)

BTPHB[2:0]: Minimum OFF time setting of GDR in phase B

000b: 0.27uS 001b: 0.34uS 010b: 0.40uS 011b: 0.54uS
 100b: 0.80uS 101b: 1.54uS 110b: 3.34uS **111b: 6.58uS**

BTPHC[5:3]: Driving strength of phase C

000b: strength 1 001b: strength 2 **010b: strength 3** 011b: strength 4
 100b: strength 5 101b: strength 6 110b: strength 7 111b: strength 8 (strongest)

BTPHC[2:0]: Minimum OFF time setting of GDR in phase C

000b: 0.27uS 001b: 0.34uS 010b: 0.40uS 011b: 0.54uS
 100b: 0.80uS 101b: 1.54uS 110b: 3.34uS **111b: 6.58uS**

(8) DEEP SLEEP (DSLPL) (R07H)

Action	W/R	C/D	D7	D6	D5	D4	D3	D2	D1	D0
Deep Sleep	0	0	0	0	0	0	0	1	1	1
	0	1	1	0	1	0	0	1	0	1

After this command is transmitted, the chip will enter Deep Sleep Mode to save power. Deep Sleep Mode will return to Standby Mode by hardware reset. The only one parameter is a check code, the command will be executed if check code = 0xA5.

(9) DATA START TRANSMISSION 1 (DTM1) (R10H)

Action	W/R	C/D	D7	D6	D5	D4	D3	D2	D1	D0
Starting data transmission	0	0	0	0	0	1	0	0	0	0
	0	1	Pixel1	Pixel2	Pixel3	Pixel4	Pixel5	Pixel6	Pixel7	Pixel8
	0	1	:	:	:	:	:	:	:	:
	0	1	Pixel(n-7)	Pixel(n-6)	Pixel(n-5)	Pixel(n-4)	Pixel(n-3)	Pixel(n-2)	Pixel(n-1)	Pixel(n)

This command starts transmitting data and write them into SRAM.

In KW mode, this command writes "OLD" data to SRAM.

In KWR mode, this command writes "B/W" data to SRAM.

In Program mode, this command writes "OTP" data to SRAM for programming.

(10) DATA STOP (DSP) (R11H)

Action	W/R	C/D	D7	D6	D5	D4	D3	D2	D1	D0
Stopping data transmission	0	0	0	0	0	1	0	0	0	1
	1	1	data flag	-	-	-	-	-	-	-

Check the completeness of data. If data is complete, start to refresh display.

Data_flag: Data flag of receiving user data.

0: Driver didn't receive all the data.

1: Driver has already received all the one-frame data (DTM1 and DTM2).

After "Data Start" (R10h) or "Data Stop" (R11h) commands and when data_flag=1, the refreshing of panel starts and BUSY_N signal will become "0".

(11) DISPLAY REFRESH (DRF) (R12H)

Action	W/R	C/D	D7	D6	D5	D4	D3	D2	D1	D0
Refreshing the display	0	0	0	0	0	1	0	0	1	0

While user sent this command, driver will refresh display (data/VCOM) according to SRAM data and LUT.

After Display Refresh command, BUSY_N signal will become "0" and the refreshing of panel starts.

The waiting interval from BUSY_N falling to the first FLG command must be larger than 200uS.

(12) DATA START TRANSMISSION 2 (DTM2) (R13H)

Action	W/R	C/D	D7	D6	D5	D4	D3	D2	D1	D0	
Starting data transmission	0	0	0	0	0	1	0	0	1	1	13H
	0	1	Pixel1	Pixel2	Pixel3	Pixel4	Pixel5	Pixel6	Pixel7	Pixel8	00H
	0	1	:	:	:	:	:	:	:	:	00H
	0	1	Pixel(n-7)	Pixel(n-6)	Pixel(n-5)	Pixel(n-4)	Pixel(n-3)	Pixel(n-2)	Pixel(n-1)	Pixel(n)	00H

This command starts transmitting data and write them into SRAM.

In KW mode, this command writes "NEW" data to SRAM.

In KWR mode, this command writes "RED" data to SRAM.

(13) AUTO SEQUENCE (AUTO) (R17H)

Action	W/R	C/D	D7	D6	D5	D4	D3	D2	D1	D0	
Auto Sequence	0	0	0	0	0	1	0	1	1	1	17H
	0	1	1	0	1	0	0	1	0	1	A5H

The command can enable the internal sequence to execute several commands continuously. The successive execution can minimize idle time to avoid unnecessary power consumption and reduce the complexity of host's control procedure. The sequence contains several operations, including PON, DRF, POF, DSLP.

AUTO (0x17) + Code(0xA5) = (PON → DRF → POF)

AUTO (0x17) + Code(0xA7) = (PON → DRF → POF → DSLP)

(14) VCOM LUT (LUTC) (R20H)

Action	W/R	C/D	D7	D6	D5	D4	D3	D2	D1	D0
Build Look-up Table for VCOM (57-byte command, structure of bytes 2~8 repeated 8 times)	0	0	0	0	1	0	0	0	0	0
	0	1	Group Repeat Time [7:0]							
	0	1	Level Select 1-1[1:0]	Frame number 1-1 [5:0]						
	0	1	Level Select 1-2[1:0]	Frame number 1-2 [5:0]						
	0	1	Level Select 2-1[1:0]	Frame number 2-1 [5:0]						
	0	1	Level Select 2-2[1:0]	Frame number 2-2 [5:0]						
	0	1	State 1 repeat times [7:0]							
	0	1	State 2 repeat times [7:0]							

This command stores VCOM Look-Up Table with 8 groups of data. This LUT includes 8 kinds of groups; each group is of 7 bytes. Each group is divided to 2 states and group repeat number. Each state made up 2 phases and each phase is combined with repeat time, level selection and frame number.

Bytes 2, 9, 16, 23, 30, ... :

Group repeat times

0000 0000b: No repeat

0000 0001b ~ 1111 1111b: Repeat 1 ~ 255times

Bytes 3~6, 10~13, 17~20, 24~27, 31~34, ...:

[D7:D6] Level selection

00b: VCOM_DC

01b: VSH+VCOM_DC (VCOMH)

10b: VSL-VCOM_DC (VCOML)

11b: Floating

[D5:D0] Number of Frames (state1 & state2)

00 0000b: 0 time

:
:
:

11 1111b: 63 times

Bytes 7~8, 14~15, 21~22, 28~29, 35~36, ...:

State 1 & State 2 repeat times

0000 0000b: No repeat

0000 0001b ~ 1111 1111b: 1 ~ 255times

If KW/R=0 (KWR mode), all 8 groups are used.

If KW/R=1 (KW mode), only 6 groups are used.

(15) W2W LUT (LUTWW) (R21H)

Action	W/R	C/D	D7	D6	D5	D4	D3	D2	D1	D0
Build White Look-up Table for W2W (43-byte command, structure of bytes 2~8 repeated 6 times)	0	0	0	0	1	0	0	0	0	1
	0	1	Group Repeat Time [7:0]							
	0	1	Level Select 1-1[1:0]	Frame number 1-1 [5:0]						
	0	1	Level Select 1-2[1:0]	Frame number 1-2 [5:0]						
	0	1	Level Select 2-1[1:0]	Frame number 2-1 [5:0]						
	0	1	Level Select 2-2[1:0]	Frame number 2-2 [5:0]						
	0	1	State 1 repeat times [7:0]							
	0	1	State 2 repeat times [7:0]							

This command stores LUTW2W Look-Up Table with 6 groups of data. This LUT includes 6 kinds of groups; each group is of 7 bytes. Each group is divided to 2states and group repeat number. Each state made up 2 phases and each phase is combined with repeat time, level selection and frame number.

Bytes 2, 9, 16, 23, 30,.... :

Group repeat times

0000 0000b: No repeat

0000 0001b ~ 1111 1111b: Repeat 1 ~ 255times

Bytes 3~6, 10~13, 17~20, 24~27, 31~34.....:

[D7:D6] Level selection

00b: 0V

01b: VSH

10b: VSL

11b: VDHR

[D5:D0] Number of Frames (state1 & state2)

00 0000b: 0 time

: :

: :

11 1111b: 63 times

Bytes 7~8, 14~15, 21~22, 28~29, 35~36...:

State 1 & State 2 repeat times

0000 0000b: No repeat

0000 0001b ~ 1111 1111b: 1 ~ 255times

If KW/R=0 (KWR mode), LUTWW is not used.

If KW/R=1 (KW mode), LUTWW is used.

(16) K2W LUT (LUTKW / LUTR) (R22H)

Action	W/R	C/D	D7	D6	D5	D4	D3	D2	D1	D0		
Build Look-up Table for K2W or Red (57-byte command, structure of bytes 2~8 repeated 8 times)	0	0	0	0	1	0	0	0	0	0	20H	
	0	1	Group Repeat Time [7:0]									00H
	0	1	Level Select 1-1[1:0]	Frame number 1-1 [5:0]								00H
	0	1	Level Select 1-2[1:0]	Frame number 1-2 [5:0]								00H
	0	1	Level Select 2-1[1:0]	Frame number 2-1 [5:0]								00H
	0	1	Level Select 2-2[1:0]	Frame number 2-2 [5:0]								00H
	0	1	State 1 repeat times [7:0]									00H
	0	1	State 2 repeat times [7:0]									00H

This command stores LUTKW / LUTR Look-Up Table with 8 groups of data. This LUT includes 8 kinds of groups; each group is of 7 bytes. Each group is divided to 2 states and group repeat number. Each state made up 2 phases and each phase is combined with repeat time, level selection and frame number.

Bytes 2, 9, 16, 23, 30, ... :

Group repeat times

0000 0000b: No repeat

0000 0001b ~ 1111 1111b: Repeat 1 ~ 255times

Bytes 3~6, 10~13, 17~20, 24~27, 31~34, ...:

[D7:D6] Level selection

00b: 0V

01b: VSH

10b: VSL

11b: VDHR

[D5:D0] Number of Frames (state1 & state2)

00 0000b: 0 time

: :

11 1111b: 63 times

Bytes 7~8, 14~15, 21~22, 28~29, 35~36, ...:

State 1 & State 2 repeat times

0000 0000b: No repeat

0000 0001b ~ 1111 1111b: 1 ~ 255times

If KW/R=0 (KWR mode), all 8 groups are used.

If KW/R=1 (KW mode), only 6 groups are used.

(17) W2K LUT (LUTWK / LUTW) (R23H)

This command builds Look-up Table for White-to-Black. Please refer to W2W LUT (LUTWW) for similar definition details.

Regardless of KW/R=0 or KW/R=1, LUTWK/LUTW is used.

(18) K2K LUT (LUTKK / LUTK) (R24H)

This command builds Look-up Table for Black-to-Black. Please refer to W2W LUT (LUTWW) for similar definition details.

Regardless of KW/R=0 or KW/R=1, LUTKK/LUTK is used.

Note: All LUTs are independent of each other and could be deal with separately. If waveform time is different for each LUT, IC would elect longest LUT as refresh time and fill 0 (GND) to remaining refresh time for other LUT.

(19) LUT OPTION (LUTOPT) (R2AH)

Action	W/R	C/D	D7	D6	D5	D4	D3	D2	D1	D0	
LUT Option	0	0	0	0	1	0	1	0	1	0	2AH
	0	1	EOPT	ESO	-	-	-	-	-	-	00H
	0	1	STATE_XON[7:0]								00H
	0	1	STATE_XON[15:8]								00H
	0	1	GROUP_KWE[7:0]								FFH
	0	1	-	-	-	-	-	-	ATRED	NORED	00H

This command sets XON and the several options of KWR mode's LUT.

EOPT: LUT sequence option
0: Disable 1: Enable

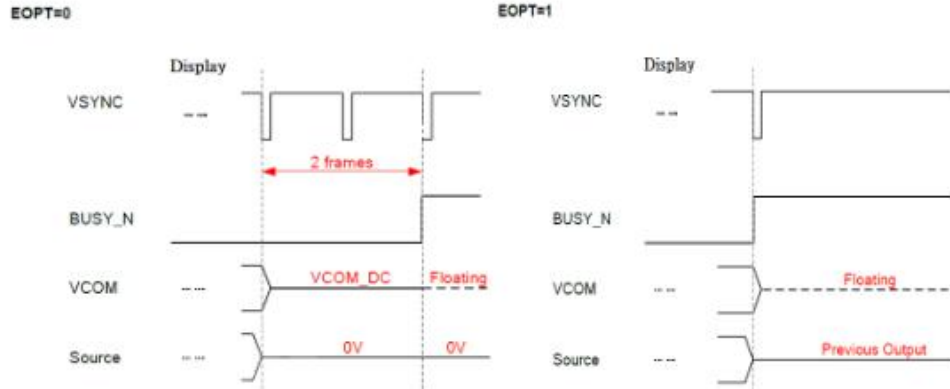

ESO: LUT sequence option 2
STATE_XON[15:0]:

All Gate ON control (Each bit controls one state, STATE_XON [0] for Group-1/State-1, STATE_XON [1] for Group-1/State-2)

- 0000 0000 0000 0000b: no All-Gate-ON
- 0000 0000 0000 0001b: Group-1/State-1 All-Gate-ON
- 0000 0000 0000 0011b: Group-1/State-1 and Group-1/State-2 All-Gate-ON
- 0000 0000 0000 0111b: Group-1/State-1, Group-1/State-2 and Group-2/State-1 All-Gate-ON
- : :

GROUP_KWE[7:0]:

The control bits are only available when KW/R=0 (KWR mode) and (ATRED | NORED)=1

There are only 8 groups in the K/W LUT. Each bit controls one group.

- 1111 1111b: all groups are executed sequentially.
- 1111 1110b: only Group-1 is bypassed.
- 1111 1100b: Group-1 and Group-2 are bypassed.
- : :

ATRED: Automatic mode. The option is only available when KW/R=0

NORED: No Red data. The option is only available when KW/R=0

(20) PLL CONTROL (PLL) (R30H)

Action	W/R	C/D	D7	D6	D5	D4	D3	D2	D1	D0	
Controlling PLL	0	0	0	0	1	1	0	0	0	0	30H
	0	1	-	-	-	FRS[4:0]				09H	

The command controls the PLL clock frequency. The PLL structure must support the following frame rates:

FMR[4:0]: Frame rate setting

FRS	Frame rate	FRS	Frame rate
00000	5Hz	10000	85Hz
00001	10Hz	10001	90Hz
00010	15Hz	10010	95Hz
00011	20Hz	10011	100Hz
00100	25Hz	10100	105Hz
00101	30Hz	10101	110Hz
00110	35Hz	10110	115Hz
00111	40Hz	10111	120Hz
01000	45Hz	11000	130Hz
01001	50Hz	11001	140Hz
01010	55Hz	11010	150Hz
01011	60Hz	11011	160Hz
01100	65Hz	11100	170Hz
01101	70Hz	11101	180Hz
01110	75Hz	11110	190Hz
01111	80Hz	11111	200Hz

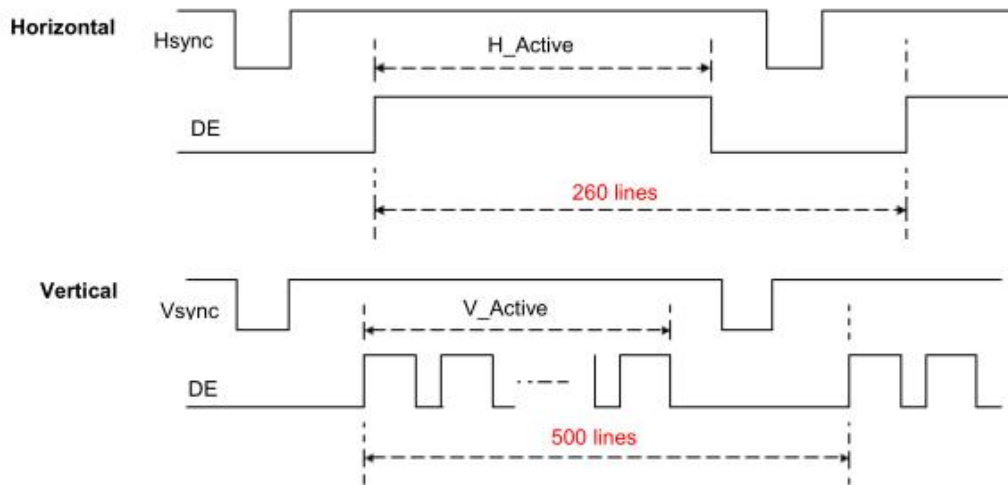

(21) TEMPERATURE SENSOR CALIBRATION (TSC) (R40H)

Action	W/R	C/D	D7	D6	D5	D4	D3	D2	D1	D0
Sensing Temperature	0	0	0	1	0	0	0	0	0	0
	1	1	D10/TS7	D9/TS6	D8/TS5	D7/TS4	D6 / TS3	D5 / TS2	D4 / TS1	D3 / TS0
	1	1	D2	D1	D0	-	-	-	-	-

This command enables internal or external temperature sensor, and reads the result.

TS[7:0]: When TSE (R41h) is set to 0, this command reads internal temperature sensor value.

D[10:0]: When TSE (R41h) is set to 1, this command reads external LM75 temperature sensor value.

TS[7:0]/D[10:3]	Temperature (°C)	TS[7:0]/D[10:3]	Temperature(°C)	TS[7:0]/D[10:3]	Temperature(°C)
1110_0111	-25	0000_0000	0	0001_1001	25
1110_1000	-24	0000_0001	1	0001_1010	26
1110_1001	-23	0000_0010	2	0001_1011	27
1110_1010	-22	0000_0011	3	0001_1100	28
1110_1011	-21	0000_0100	4	0001_1101	29
1110_1100	-20	0000_0101	5	0001_1110	30
1110_1101	-19	0000_0110	6	0001_1111	31
1110_1110	-18	0000_0111	7	0010_0000	32
1110_1111	-17	0000_1000	8	0010_0001	33
1111_0000	-16	0000_1001	9	0010_0010	34
1111_0001	-15	0000_1010	10	0010_0011	35
1111_0010	-14	0000_1011	11	0010_0100	36
1111_0011	-13	0000_1100	12	0010_0101	37
1111_0100	-12	0000_1101	13	0010_0110	38
1111_0101	-11	0000_1110	14	0010_0111	39
1111_0110	-10	0000_1111	15	0010_1000	40
1111_0111	-9	0001_0000	16	0010_1001	41
1111_1000	-8	0001_0001	17	0010_1010	42
1111_1001	-7	0001_0010	18	0010_1011	43
1111_1010	-6	0001_0011	19	0010_1100	44
1111_1011	-5	0001_0100	20	0010_1101	45
1111_1100	-4	0001_0101	21	0010_1110	46
1111_1101	-3	0001_0110	22	0010_1111	47
1111_1110	-2	0001_0111	23	0011_0000	48
1111_1111	-1	0001_1000	24	0011_0001	49

(22) TEMPERATURE SENSOR ENABLE (TSE) (R41H)

Action	W/R	C/D	D7	D6	D5	D4	D3	D2	D1	D0
Enable Temperature Sensor /Offset	0	0	0	1	0	0	0	0	0	1
	0	1	TSE	-	-	-	TO[3:0]			

This command selects Internal or External temperature sensor.

TSE: Internal temperature sensor switch

0: Enable (default)

1: Disable; using external sensor.

TO[3:0]: Temperature offset.

TO[3:0]	Calculation
0000 b	+0 (Default)
0001	+1
0010	+2
0011	+3
0100	+4
0101	+5
0110	+6
0111	+7

TO[3:0]	Calculation
1000	-8
1001	-7
1010	-6
1011	-5
1100	-4
1101	-3
1110	-2
1111	-1

(26) VCOM AND DATA INTERVAL SETTING (CDI) (R50H)

Action	W/R	C/D	D7	D6	D5	D4	D3	D2	D1	D0
Set Interval between VCOM and Data	0	0	0	1	0	1	0	0	0	0
	0	1	VBD[1:0]		DDX[1:0]		CDI[3:0]			

50h
D7h

This command indicates the interval of VCOM and data output. When setting the vertical back porch, the total blanking will be kept (20 Hsync).

VBD[1:0]: Border data selection

KWR mode (KW/R=0)

DDX[0]	VBD[1:0]	LUT
0	00	Floating
	01	LUTR
	10	LUTW
	11	LUTK
1 (Default)	00	LUTK
	01	LUTW
	10	LUTR
	11	Floating

KW mode (KW/R=1)

DDX[0]	VBD[1:0]	LUT
0	00	Floating
	01	LUTKW (1 → 0)
	10	LUTWK (0 → 1)
	11	Floating
1 (Default)	00	Floating
	01	LUTWK (1 → 0)
	10	LUTKW (0 → 1)
	11	Floating

DDX[1:0]: Data polarity.

Under KWR mode (KW/R=0):

DDX[1] is for RED data.
DDX[0] is for B/W data,

DDX[1:0]	Data {Red, B/W}	LUT
00	00	LUTW
	01	LUTK
	10	LUTR
	11	LUTR
01 (Default)	00	LUTK
	01	LUTW
	10	LUTR
	11	LUTR

DDX[1:0]	Data {Red, B/W}	LUT
10	00	LUTR
	01	LUTR
	10	LUTW
	11	LUTK
11	00	LUTR
	01	LUTR
	10	LUTK
	11	LUTW

Under KW mode (KW/R=1):

DDX[1]=0 is for KW mode with NEW/OLD,
DDX[1]=1 is for KW mode without NEW/OLD.

DDX[1:0]	Data {NEW, OLD}	LUT
00	00	LUTWW (0 → 0)
	01	LUTKW (1 → 0)
	10	LUTWK (0 → 1)
	11	LUTKK (1 → 1)
01 (Default)	00	LUTKK (0 → 0)
	01	LUTWK (1 → 0)
	10	LUTKW (0 → 1)
	11	LUTWW (1 → 1)

DDX[1:0]	Data {NEW}	LUT
10	0	LUTKW (1 → 0)
	1	LUTWK (0 → 1)
11	0	LUTWK (1 → 0)
	1	LUTKW (0 → 1)

CDI[3:0]: VCOM and data interval

CDI[3:0]	VCOM and Data Interval
0000	17 hsync
0001	16
0010	15
0011	14
0100	13
0101	12
0110	11
0111	10 (Default)

CDI[3:0]	VCOM and Data Interval
1000	9
1001	8
1010	7
1011	6
1100	5
1101	4
1110	3
1111	2

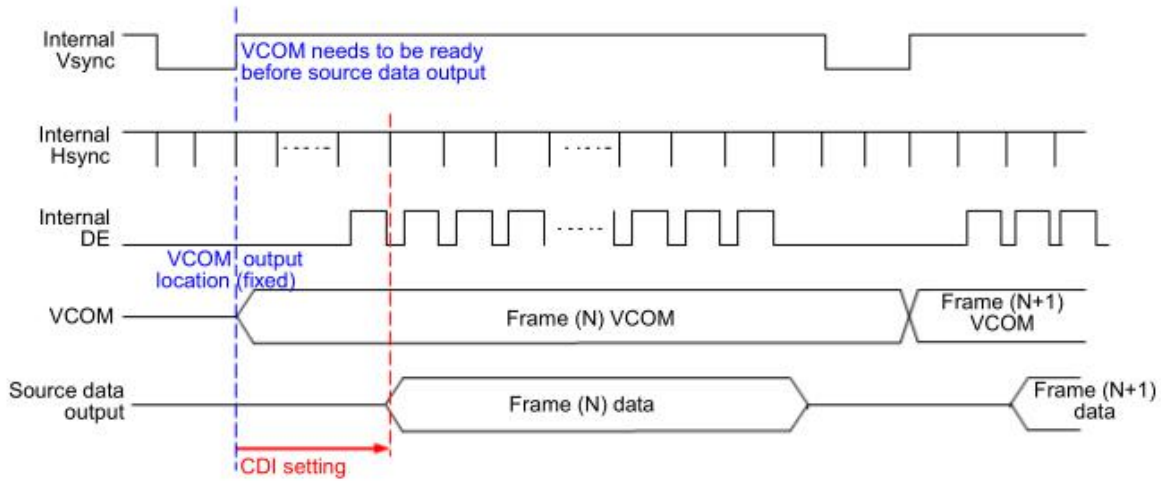

(27) LOW POWER DETECTION (LPD) (R51H)

Action	W/R	C/D	D7	D6	D5	D4	D3	D2	D1	D0
Detect Low Power	0	0	0	1	0	1	0	0	0	1
	1	1	-	-	-	-	-	-	-	LPD

This command indicates the input power condition. Host can read this flag to learn the battery condition.

LPD: Internal Low Power Detection Flag

0: Low power input ($V_{DD} < 2.5V$, selected by LVD_SEL[1:0] in command LVSEL)

1: Normal status (default)

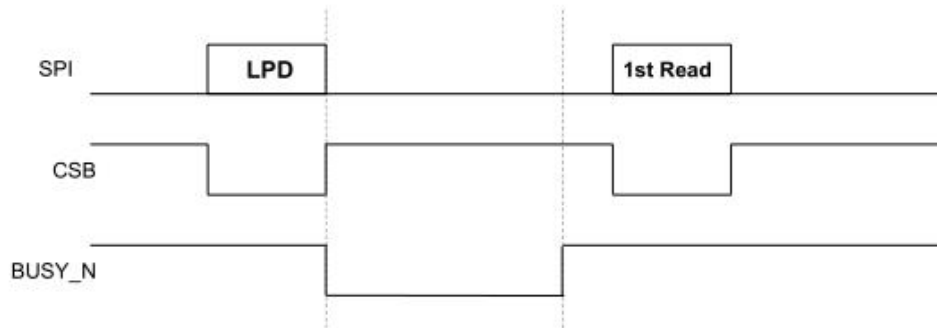

(28) TCON SETTING (TCON) (R60H)

Action	W/R	C/D	D7	D6	D5	D4	D3	D2	D1	D0	
Set Gate/Source Non-overlap Period	0	0	0	1	1	0	0	0	0	0	60h
	0	1	S2G[3:0]				G2S[3:0]				22h

This command defines non-overlap period of Gate and Source.

S2G[3:0] or G2S[3:0]: Source to Gate / Gate to Source Non-overlap period

S2G[3:0] or G2S[3:0]	Period	S2G[3:0] or G2S[3:0]	Period
0000 b	4	1000 b	36
0001	8	1001	40
0010	12 (Default)	1010	44
0011	16	1011	48
0100	20	1100	52
0101	24	1101	56
0110	28	1110	60
0111	32	1111	64

Period Unit = 650 nS.

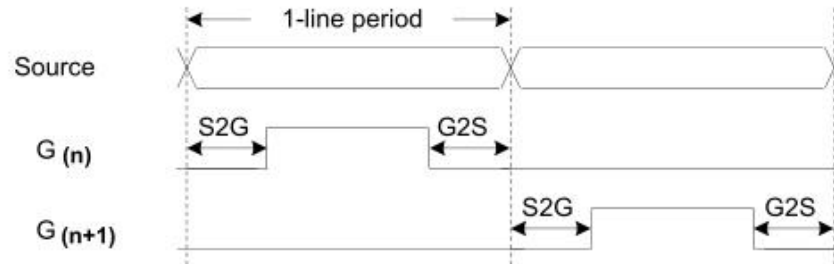

(29) RESOLUTION SETTING (TRES) (R61H)

Action	W/R	C/D	D7	D6	D5	D4	D3	D2	D1	D0	
Set Display Resolution	0	0	0	1	1	0	0	0	0	1	61h
	0	1	HRES[7:3]					0	0	0	00h
	0	1	-	-	-	-	-	-	-	VRES[8]	00h
	0	1	VRES[7:0]								00h

This command defines alternative resolution and this setting is of higher priority than the RES[1:0] in R00H (PSR).

HRES[7:3]: Horizontal Display Resolution

VRES[8:0]: Vertical Display Resolution

Active channel calculation, assuming HRES[7:3]=0, VRES[8:0]=0:

Gate: First active gate = G0;
Last active gate = VRES[8:0] - 1

Source: First active source = S0;
Last active source = HRES[7:3]*8 - 1

Example: 128 (source) x 272 (gate), assuming HRES[7:3]=0, VRES[8:0]=0

Gate: First active gate = G0,
Last active gate = G271; (VRES[8:0] = 272, 272 - 1 = 271)

Source: First active source = S0,
Last active source = S127; (HRES[7:3]=16, 16*8 - 1 = 127)

(30) GATE/SOURCE START SETTING (GSST) (R65H)

Action	W/R	C/D	D7	D6	D5	D4	D3	D2	D1	D0	
Set Gate/Source Start	0	0	0	1	1	0	0	1	0	1	65h
	0	1	HST[7:3]					0	0	0	00h
	0	1	-	-	-	-	-	-	-	VST[8]	00h
	0	1	VST[7:0]								00h

This command defines resolution start gate/source position.

HST[7:3]: Horizontal Display Start Position (Source)

VST[8:0]: Vertical Display Start Position (Gate)

Example : For 128(Source) x 240(Gate)

HST[7:3] = 4 (HST[8:0] = 4*8 = 32),
VST[8:0] = 32

Gate: First active gate = G32 (VST[8:0] = 32),
Last active gate = G271 (VST[8:0] = 32, VRES[8:0] = 240, 32+240-1=271)

Source: First active source = S32 (HST[7:3] = 32),
Last active source = S159 (HST[7:3] = 32, HRES[8:0] = 128, 32+128-1=159)

(31) REVISION (REV) (R70H)

Action	W/R	C/D	D7	D6	D5	D4	D3	D2	D1	D0	
Chip Revision	0	0	0	1	1	1	0	0	0	0	70h
	1	1	RESERVED								FFh
	1	1	CHIP_REV[7:0]								09h
	1	1	LUT_REV[7:0]								FFh
	1	1	LUT_REV[15:8]								FFh
	1	1	LUT_REV[23:16]								FFh

The LUT_REV is read from OTP address = 0x0017~0x0019 / 0x1017~0x1019.

CHIP_REV[7:0]: Chip Revision, fixed at 0x09h.

(32) GET STATUS (FLG) (R71H)

Action	W/R	C/D	D7	D6	D5	D4	D3	D2	D1	D0	
Read Flags	0	0	0	1	1	1	0	0	0	1	71h
	1	1	-	PTL_flag	I ² C_ERR	I ² C_BUSYN	data_flag	PON	POF	BUSY_N	13h

This command reads the IC status.

PTL_FLAG Partial display status (high: partial mode)

I²C_ERR: I²C master error status

I²C_BUSYN: I²C master busy status (low active)

data_flag: Driver has already received all the one frame data

PON: Power ON status

POF: Power OFF status

BUSY_N: Driver busy status (low active)

(33) CYCLIC REDUNDANCY CHECK (CRC) (R72H)

Action	R/W	A0	D7	D6	D5	D4	D3	D2	D1	D0	
Cyclic redundancy check	R	0	0	1	1	1	0	0	1	0	72h
	R	1	CRC_MSB[7:0]								FFh
	R	1	CRC_LSB[7:0]								FFh

This command reads Cyclic redundancy check(CRC) result.

The calculation only includes 0x0000~0x1FEF OTP data..

Polynomial = $x^{16} + x^{12} + x^5 + 1$, initial vaulte: 16'hFFFF

The result will be reset after this command.

CRC_MSB[7:0]: Most significant bits of CRC result

CRC_LSB[7:0]: Most significant bits of CRC result

(34) AUTO MEASURE VCOM (AMV) (R80H)

Action	W/R	C/D	D7	D6	D5	D4	D3	D2	D1	D0
Automatically measure VCOM	0	0	1	0	0	0	0	0	0	0
	0	1	-	-	AMVT[1:0]		XON	AMVS	AMV	AMVE

80h
10h

This command reads the IC status.

AMVT[1:0]: Auto Measure VCOM Time

00b: 3s

10b: 8s

01b: 5s (default)

11b: 10s

XON: All Gate ON of AMV

0: Gate normally scan during Auto Measure VCOM period. (default)

1: All Gate ON during Auto Measure VCOM period.

AMVS: Source output of AMV

0: Source output 0V during Auto Measure VCOM period. (default)

1: Source output VDHR during Auto Measure VCOM period.

AMV: Analog signal

0: Get VCOM value with the VV command (R81h) (default)

1: Get VCOM value in analog signal. (External analog to digital converter)

AMVE: Auto Measure VCOM Enable (/Disable)

0: No effect (default)

1: Trigger auto VCOM sensing.

(35) VCOM VALUE (VV) (R81H)

Action	W/R	C/D	D7	D6	D5	D4	D3	D2	D1	D0	
Automatically measure VCOM	0	0	1	0	0	0	0	0	0	1	81h
	1	1	-	-	VV[6:0]						00h

This command gets the VCOM value.

VV[6:0]: VCOM Value Output

VV [6:0]	VCOM Voltage (V)	VV [6:0]	VCOM Voltage (V)	VV [6:0]	VCOM Voltage (V)
000000b	-0.1	0101011b	-4.4	1010110b	-8.7
0000001b	-0.2	0101100b	-4.5	1010111b	-8.8
0000010b	-0.3	0101101b	-4.6	1011000b	-8.9
0000011b	-0.4	0101110b	-4.7	1011001b	-9
0000100b	-0.5	0101111b	-4.8	1011010b	-9.1
0000101b	-0.6	0110000b	-4.9	1011011b	-9.2
0000110b	-0.7	0110001b	-5	1011100b	-9.3
0000111b	-0.8	0110010b	-5.1	1011101b	-9.4
0001000b	-0.9	0110011b	-5.2	1011110b	-9.5
0001001b	-1	0110100b	-5.3	1011111b	-9.6
0001010b	-1.1	0110101b	-5.4	1100000b	-9.7
0001011b	-1.2	0110110b	-5.5	1100001b	-9.8
0001100b	-1.3	0110111b	-5.6	1100010b	-9.9
0001101b	-1.4	0111000b	-5.7	1100011b	-10
0001110b	-1.5	0111001b	-5.8	1100100b	-10.1
0001111b	-1.6	0111010b	-5.9	1100101b	-10.2
0010000b	-1.7	0111011b	-6	1100110b	-10.3
0010001b	-1.8	0111100b	-6.1	1100111b	-10.4
0010010b	-1.9	0111101b	-6.2	1101000b	-10.5
0010011b	-2	0111110b	-6.3	1101001b	-10.6
0010100b	-2.1	0111111b	-6.4	1101010b	-10.7
0010101b	-2.2	1000000b	-6.5	1101011b	-10.8
0010110b	-2.3	1000001b	-6.6	1101100b	-10.9
0010111b	-2.4	1000010b	-6.7	1101101b	-11
0011000b	-2.5	1000011b	-6.8	1101110b	-11.1
0011001b	-2.6	1000100b	-6.9	1101111b	-11.2
0011010b	-2.7	1000101b	-7	1110000b	-11.3
0011011b	-2.8	1000110b	-7.1	1110001b	-11.4
0011100b	-2.9	1000111b	-7.2	1110010b	-11.5
0011101b	-3	1001000b	-7.3	1110011b	-11.6
0011110b	-3.1	1001001b	-7.4	1110100b	-11.7
0011111b	-3.2	1001010b	-7.5	1110101b	-11.8
0100000b	-3.3	1001011b	-7.6	1110110b	-11.9
0100001b	-3.4	1001100b	-7.7	1110111b	-12
0100010b	-3.5	1001101b	-7.8	1111000b	-12.1
0100011b	-3.6	1001110b	-7.9	1111001b	-12.2
0100100b	-3.7	1001111b	-8	1111010b	-12.3
0100101b	-3.8	1010000b	-8.1	1111011b	-12.4
0100110b	-3.9	1010001b	-8.2	1111100b	-12.5
0100111b	-4	1010010b	-8.3	1111101b	-12.6
0101000b	-4.1	1010011b	-8.4	1111110b	-12.7
0101001b	-4.2	1010100b	-8.5		
0101010b	-4.3	1010101b	-8.6		

(36) VCOM_DC SETTING (VDCS) (R82H)

Action	W/R	C/D	D7	D6	D5	D4	D3	D2	D1	D0	
Set VCOM_DC	0	0	1	0	0	0	0	0	1	0	82h 00h
	0	1	-	-	VDCS[6:0]						

This command sets VCOM_DC value

VDCS[6:0]: VCOM_DC Setting

VDCS [6:0]	VCOM Voltage (V)	VDCS [6:0]	VCOM Voltage (V)	VDCS [6:0]	VCOM Voltage (V)
000000b	-0.1	0101011b	-4.4	1010110b	-8.7
0000001b	-0.2	0101100b	-4.5	1010111b	-8.8
0000010b	-0.3	0101101b	-4.6	1011000b	-8.9
0000011b	-0.4	0101110b	-4.7	1011001b	-9
0000100b	-0.5	0101111b	-4.8	1011010b	-9.1
0000101b	-0.6	0110000b	-4.9	1011011b	-9.2
0000110b	-0.7	0110001b	-5	1011100b	-9.3
0000111b	-0.8	0110010b	-5.1	1011101b	-9.4
0001000b	-0.9	0110011b	-5.2	1011110b	-9.5
0001001b	-1	0110100b	-5.3	1011111b	-9.6
0001010b	-1.1	0110101b	-5.4	1100000b	-9.7
0001011b	-1.2	0110110b	-5.5	1100001b	-9.8
0001100b	-1.3	0110111b	-5.6	1100010b	-9.9
0001101b	-1.4	0111000b	-5.7	1100011b	-10
0001110b	-1.5	0111001b	-5.8	1100100b	-10.1
0001111b	-1.6	0111010b	-5.9	1100101b	-10.2
0010000b	-1.7	0111011b	-6	1100110b	-10.3
0010001b	-1.8	0111100b	-6.1	1100111b	-10.4
0010010b	-1.9	0111101b	-6.2	1101000b	-10.5
0010011b	-2	0111110b	-6.3	1101001b	-10.6
0010100b	-2.1	0111111b	-6.4	1101010b	-10.7
0010101b	-2.2	1000000b	-6.5	1101011b	-10.8
0010110b	-2.3	1000001b	-6.6	1101100b	-10.9
0010111b	-2.4	1000010b	-6.7	1101101b	-11
0011000b	-2.5	1000011b	-6.8	1101110b	-11.1
0011001b	-2.6	1000100b	-6.9	1101111b	-11.2
0011010b	-2.7	1000101b	-7	1110000b	-11.3
0011011b	-2.8	1000110b	-7.1	1110001b	-11.4
0011100b	-2.9	1000111b	-7.2	1110010b	-11.5
0011101b	-3	1001000b	-7.3	1110011b	-11.6
0011110b	-3.1	1001001b	-7.4	1110100b	-11.7
0011111b	-3.2	1001010b	-7.5	1110101b	-11.8
0100000b	-3.3	1001011b	-7.6	1110110b	-11.9
0100001b	-3.4	1001100b	-7.7	1110111b	-12
0100010b	-3.5	1001101b	-7.8	1111000b	-12.1
0100011b	-3.6	1001110b	-7.9	1111001b	-12.2
0100100b	-3.7	1001111b	-8	1111010b	-12.3
0100101b	-3.8	1010000b	-8.1	1111011b	-12.4
0100110b	-3.9	1010001b	-8.2	1111100b	-12.5
0100111b	-4	1010010b	-8.3	1111101b	-12.6
0101000b	-4.1	1010011b	-8.4	1111110b	-12.7
0101001b	-4.2	1010100b	-8.5		
0101010b	-4.3	1010101b	-8.6		

(37) PARTIAL WINDOW (PTL) (R90H)

Action	W/R	C/D	D7	D6	D5	D4	D3	D2	D1	D0		
Set Partial Window	0	0	1	0	0	0	0	0	1	0	90h	
	0	1	HRST[7:3]					0	0	0		00h
	0	1	HRED[7:3]					1	1	1		07h
	0	1	-	-	-	-	-	-	-	VRST[8]		00h
	0	1	VRST[7:0]					-	-	-		00h
	0	1	-	-	-	-	-	-	-	VRED[8]		00h
	0	1	VRED[7:0]					-	-	-		00h
	0	1	-	-	-	-	-	-	-	PT_SCAN		01h

This command sets partial window.

HRST[7:3]: Horizontal start channel bank. (value 00h~1Dh)

HRED[7:3]: Horizontal end channel bank. (value 00h~1Dh). HRED must be greater than HRST.

VRST[8:0]: Vertical start line. (value 000h~1DFh)

VRED[8:0]: Vertical end line. (value 000h~1DFh). VRED must be greater than VRST.

PT_SCAN: 0: Gates scan only inside of the partial window.

1: Gates scan both inside and outside of the partial window. (default)

(38) PARTIAL IN (PTIN) (R91H)

Action	W/R	C/D	D7	D6	D5	D4	D3	D2	D1	D0	
Partial In	0	0	1	0	0	1	0	0	0	1	91h

This command makes the display enter partial mode.

(39) PARTIAL OUT (PTOUT) (R92H)

Action	W/R	C/D	D7	D6	D5	D4	D3	D2	D1	D0	
Partial Out	0	0	1	0	0	1	0	0	1	0	92h

This command makes the display exit partial mode and enter normal mode.

(40) PROGRAM MODE (PGM) (RA0H)

Action	W/R	C/D	D7	D6	D5	D4	D3	D2	D1	D0	
Enter Program Mode	0	0	1	0	1	0	0	0	0	0	A0h

After this command is issued, the chip would enter the program mode.

After the programming procedure completed, a hardware reset is necessary for leaving program mode.

(41) ACTIVE PROGRAM (APG) (RA1H)

Action	W/R	C/D	D7	D6	D5	D4	D3	D2	D1	D0	
Active Program OTP	0	0	1	0	1	0	0	0	0	1	A1h

After this command is transmitted, the programming state machine would be activated.

The BUSY_N flag would fall to 0 until the programming is completed.

(42) READ OTP DATA (ROTP) (RA2H)

Action	W/R	C/D	D7	D6	D5	D4	D3	D2	D1	D0	A2h	
Read OTP data for check	0	0	1	0	1	0	0	0	1	0		
	1	1	Dummy									
	1	1	The data of address 0x000 in the OTP									
	1	1	The data of address 0x001 in the OTP									
	1	1	:									
	1	1	The data of address (n-1) in the OTP									
	1	1	The data of address (n) in the OTP									

The command is used for reading the content of OTP for checking the data of programming.

The value of (n) is depending on the amount of programmed data, the max address = 0xFF.

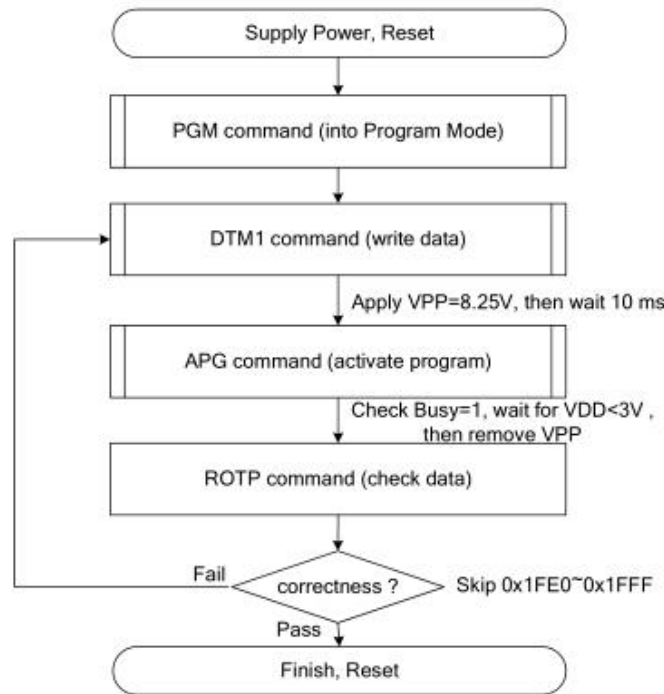

The sequence of programming OTP.

(43) CASCADE SETTING (CCSET) (RE0H)

Action	W/R	C/D	D7	D6	D5	D4	D3	D2	D1	D0
Set Cascade Option	0	0	1	1	1	0	0	0	0	0
	0	1	-	-	-	-	-	-	TSFIX	CCEN

E0h
00h

This command is used for cascade.

CCEN: Output clock enable/disable.

0: Output 0V at CL pin. (default)

1: Output clock at CL pin for slave chip.

TSFIX: Let the value of slave's temperature is same as the master's.

0: Temperature value is defined by internal temperature sensor / external LM75. (default)

1: Temperature value is defined by TS_SET[7:0] registers.

(44) POWER SAVING (PWS) (RE3H)

Action	W/R	C/D	D7	D6	D5	D4	D3	D2	D1	D0
Power Saving for VCOM & Source	0	0	1	1	1	0	0	0	1	1
	0	1	VCOM_W[3:0]				SD_W[3:0]			

E3h
00h

This command is set for saving power during refreshing period. If the output voltage of VCOM / Source is from negative to positive or from positive to negative, the power saving mechanism will be activated. The active period width is defined by the following two parameters.

VCOM_W[3:0]: VCOM power saving width (unit = line period)

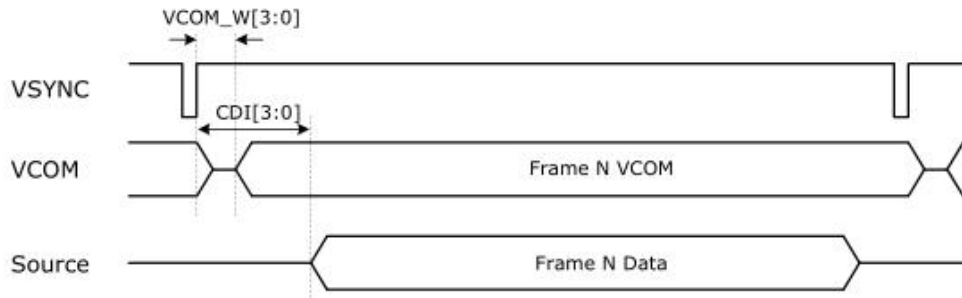

SD_W[3:0]: Source power saving width (unit = 650nS)

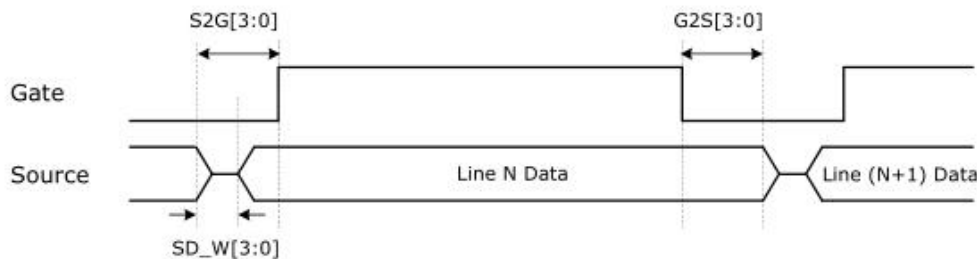

(45) LVD VOLTAGE SELECT (LVSEL) (RE4H)

Action	W/R	C/D	D7	D6	D5	D4	D3	D2	D1	D0
Select LVD Voltage	0	0	1	1	1	0	0	1	0	0
	0	1	-	-	-	-	-	-	LVD_SEL[1:0]	

E4h
03h

LVD_SEL[1:0]: Low Power Voltage selection

LVD_SEL[1:0]	LVD value
00	< 2.2 V
01	< 2.3 V
10	< 2.4 V
11	< 2.5 V (default)

(46) FORCE TEMPERATURE (TSSET) (RE5H)

Action	W/R	C/D	D7	D6	D5	D4	D3	D2	D1	D0
Force Temperature Value for Cascade	0	0	1	1	1	0	0	1	0	1
	0	1	TS_SET[7:0]							

E5h
00h

This command is used for cascade to fix the temperature value of master and slave chip.

8. Optical Specification

Measurements are made with that the illumination is under an angle of 45 degree, the detection is perpendicular unless otherwise specified

Symbol	Parameter	Conditions	Min	Typ.	Max	Units	Notes
R	White Reflectivity	White	30	35	-	%	8-1
CR	Contrast Ratio	indoor	8:1		-		8-2
GN	2Grey Level	-	-	-	-		
T update	Image update time	at 23 °C	-	14	-	sec	
Life		Temp:23 ± 3°C Humidity:55 ± 10%RH		5years			8-3

Notes: 8-1. Luminance meter: Eye-One Pro Spectrophotometer.

8-2. CR=Surface Reflectance with all white pixel/Surface Reflectance with all black pixels.

8-3. When the product is stored. The display screen should be kept white and face up.

9. Handling, Safety, and Environment Requirements

Warning

The display glass may break when it is dropped or bumped on a hard surface. Handle with care. Should the display break, do not touch the electrophoretic material. In case of contact with electrophoretic material, wash with water and soap.

Caution

The display module should not be exposed to harmful gases, such as acid and alkali gases, which corrode electronic components. Disassembling the display module.

Disassembling the display module can cause permanent damage and invalidates the warranty agreements.

Observe general precautions that are common to handling delicate electronic components. The glass can break and front surfaces can easily be damaged. Moreover the display is sensitive to static electricity and other rough environmental conditions.

Data sheet status	
Product specification	This data sheet contains final product specifications.
Limiting values	
Limiting values given are in accordance with the Absolute Maximum Rating System (IEC 134). Stress above one or more of the limiting values may cause permanent damage to the device. These are stress ratings only and operation of the device at these or at any other conditions above those given in the Characteristics sections of the specification is not implied. Exposure to limiting values for extended periods may affect device reliability.	
Application information	
Where application information is given, it is advisory and does not form part of the specification.	

10. Reliability Test

NO	Test items	Test condition
1	Low-Temperature Storage	T = -25°C, 240 h Test in white pattern
2	High-Temperature Storage	T=60°C, RH=40%, 240h Test in white pattern
3	High-Temperature Operation	T=40°C, RH=35%, 240h
4	Low-Temperature Operation	0°C, 240h
5	High-Temperature, High-Humidity Operation	T=40°C, RH=80%, 240h
6	High Temperature, High Humidity Storage	T=50°C, RH=80%, 240h Test in white pattern
7	Temperature Cycle	1 cycle:[-25°C 30min]→[+60 °C 30 min] : 50 cycles Test in white pattern
8	UV exposure Resistance	765W/m ² for 168hrs,40 °C Test in white pattern
9	ESD Gun	Air+/-15KV;Contact+/-8KV (Test finished product shell, not display only) Air+/-8KV;Contact+/-6KV (Naked EPD display, no including IC and FPC area) Air+/-4KV;Contact+/-2KV (Naked EPD display, including IC and FPC area)

Note: Put in normal temperature for 1hour after test finished, display performance is ok.

11. Block Diagram

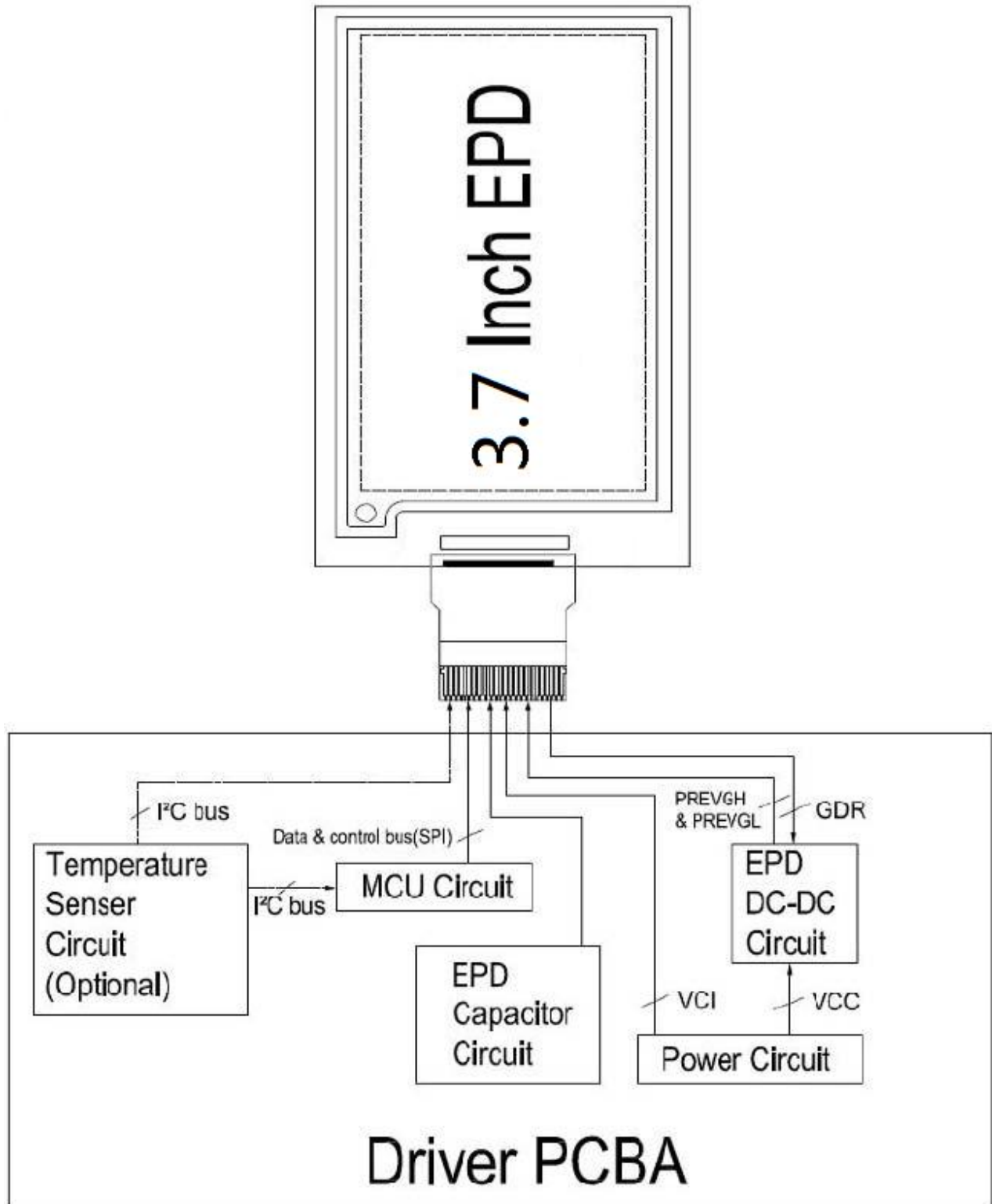

12 Typical Application Circuit with SPI Interface

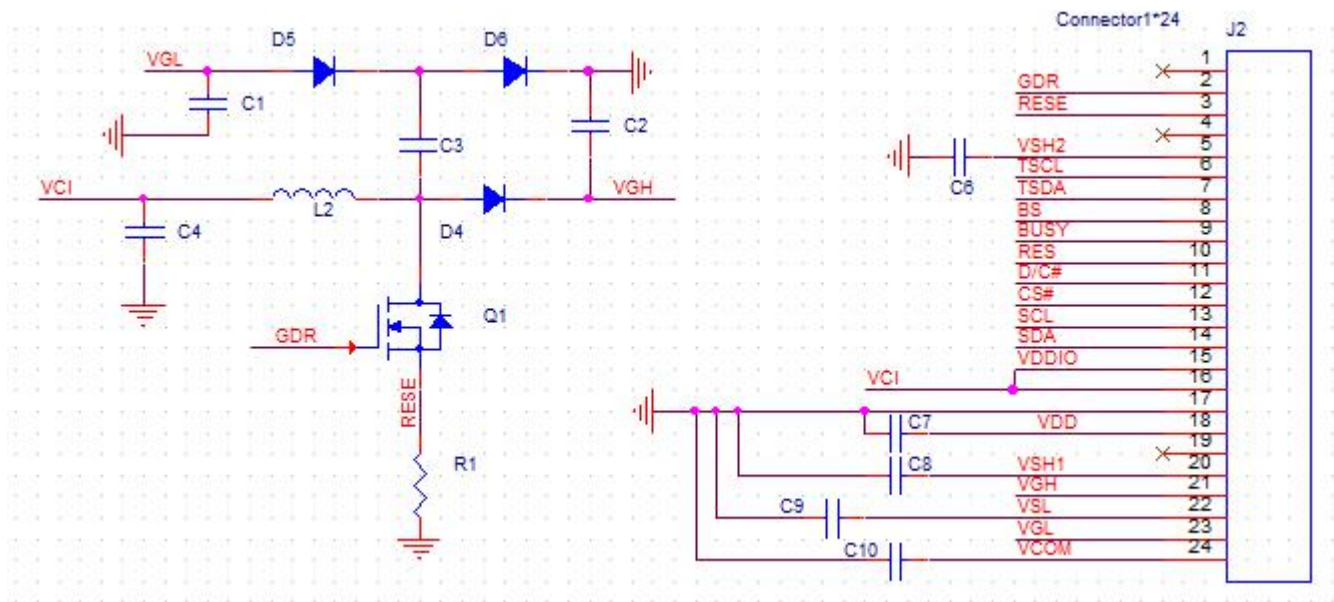

Part Name	Value	Reference Part	Requirements for spare part
C7	1uF		Voltage Rating:10v
C4	4.7uF		Voltage Rating:10v
C1 C10	1uF		Voltage Rating:25v
C2 C3 C6 C8 C9	4.7uF		Voltage Rating:25v
R1	0.47Ohm		NO
D4 D5 D6	Diode	MBR0530	(V R > 25V, I F > 500mA, I R < 1mA @ V R =15V, T a =100 o C)
Q1	NMOS	Vishay Si1308EDL	(V DS > 25V, I D > 500mA, V GS (th) < 1.5V, C iss < 200pF, R DS (on) < 400m Ω)
L2	10UH		NO

13 Typical Operating Sequence

13.1 LUT from OTP Operation Flow

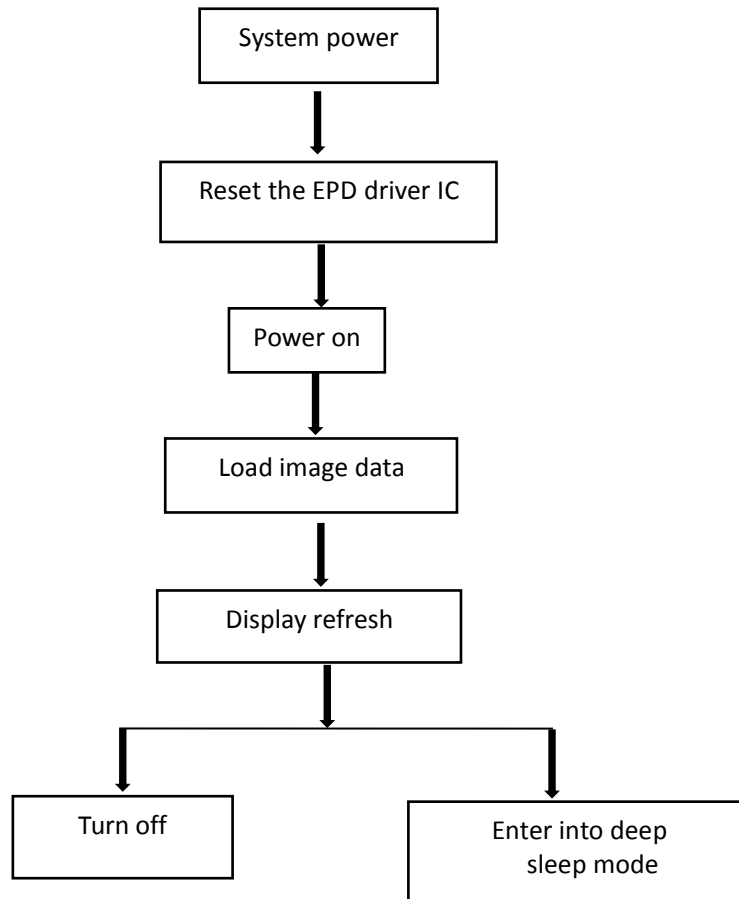

13.2 OTP Operation Reference Program Code

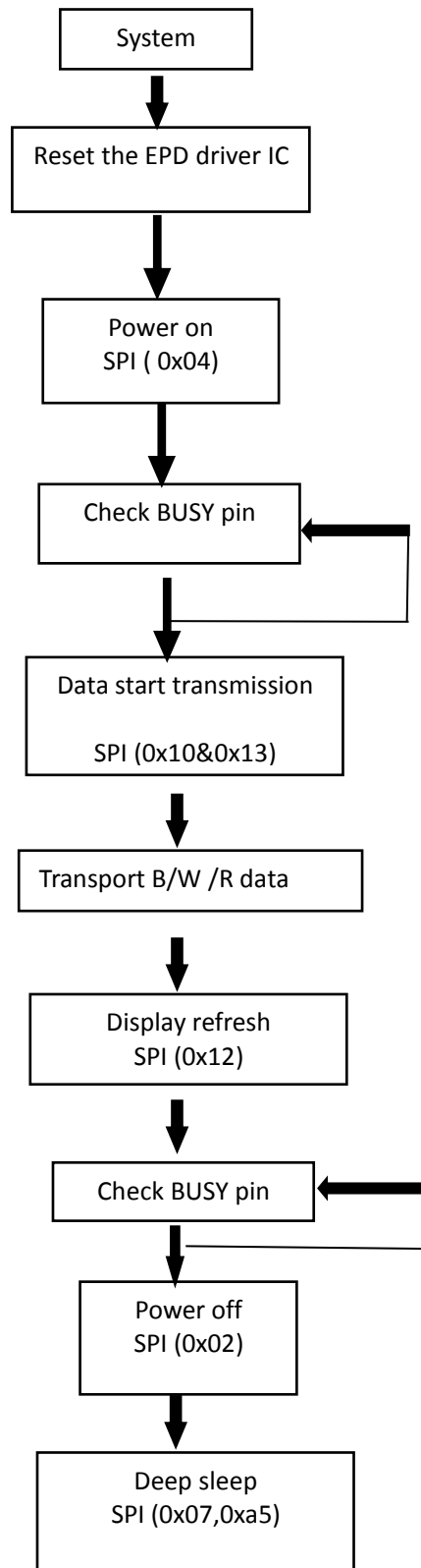

14. Part Number Definition

MT-DEP G 0370 R W U253 F4

1 2 3 4 5 6 7

- 1: MT-DEP:MT product
- 2: G:Dot matrix type
- 3: The E-paper size:3.70inch:0370
- 4: The color of E-paper:
B : Black/White R: Black/White/Red Y: Black/White/Yellow
- 5: OT range: N: Normal L/S: Low temperature H/W: High temperature
- 6: Driver type: internal temperature sensor
- 7: FPC type

15. Inspection condition

15. Inspection condition

15.1 Environment

Temperature: $23\pm 3^{\circ}\text{C}$

Humidity: $55\pm 10\%\text{RH}$

15.2 Illuminance

Brightness:1200~1500LUX;distance: 30CM;Angle:Relate 45° surround.

15.3 Inspect method

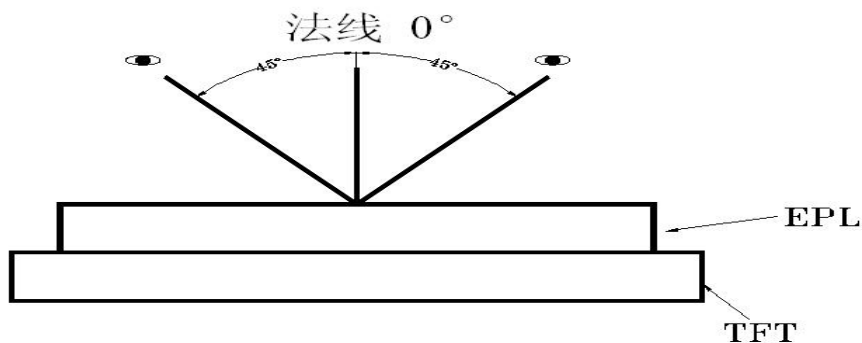

15.4 Display area

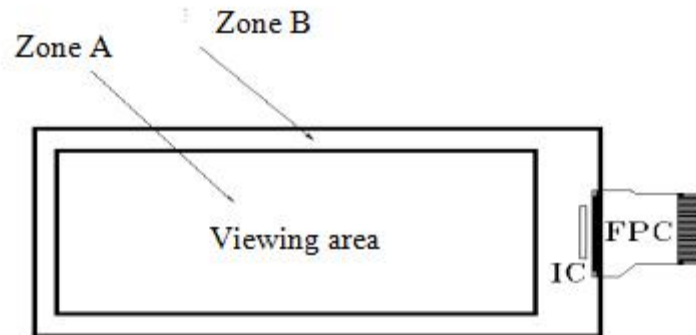

15.5 Inspection standard

15.5.1 Electric inspection standard

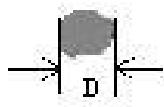
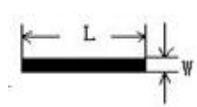
NO.	Item	Standard	Defect level	Method	Scope
1	Display	Clear display Display complete Display uniform	MA		
2	Black/White spots	 $D \leq 0.3\text{mm}$, Allowed $0.3\text{mm} < D \leq 0.5\text{mm}$, $N \leq 3$, $0.5\text{mm} < D$ Not Allow	MI	Visual inspection	Zone A
3	Black/White spots (No switch)	 $L \leq 1.0\text{mm}, W \leq 0.15\text{mm}$ negligible $1.0\text{mm} < L \leq 4.0\text{mm}$ $0.15\text{mm} < W \leq 0.5\text{mm}$ $N \leq 4$ allowable $L > 4.0\text{mm}, W > 0.5\text{mm}$ is not allowed		Visual/ Inspection card	
4	Ghost image	Allowed in switching process	MI	Visual inspection	

5	Flash dot / Multilateral	Flash points are allowed when switching screens Multilateral colors outside the frame are allowed for fixed screen time	MI	Visual/ Inspection card	Zone A Zone B
6	Segmented display	Selection segments are all displayed, and other segments are not displayed after the selection segment.	MA	Visual inspection	Zone A
7	Short circuit/ Circuit break/ Abnormal Display	Not Allow			

15.5.2 Appearance inspection standard

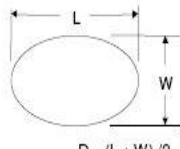
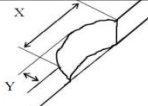
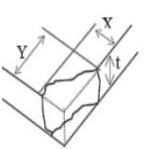
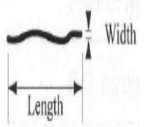
NO.	Item	Standard	Defect level	Method	Scope
1	B/W spots /Bubble/ Foreign bodies/ Dents	 <p>$D \leq 0.3\text{mm}$, Allowed $0.3\text{mm} < D \leq 0.5\text{mm}$, $N \leq 5$ $D > 0.5\text{mm}$, Not Allow</p>	MI	Visual inspection	Zone A
2	Glass crack	Not Allow	MA	Visual / Microscope	Zone A Zone B
3	\Dirty	Allowed if can be removed	MI		Zone A Zone B
4	Chips/Scratch/ Edge crown	 <p>$X \leq 3\text{mm}, Y \leq 0.5\text{mm}$</p>  <p>$2\text{mm} \leq X$ or $2\text{mm} \leq Y$ Allow</p>  <p>$W \leq 0.1\text{mm}, L \leq 5\text{mm}, n \leq 2$ Edge crown: $X \leq 0.3\text{mm}, Y \leq 3\text{mm}$</p>	MI	Visual / Microscope	Zone A Zone B

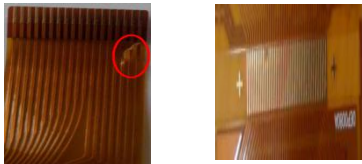
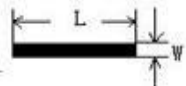
5	TFT Cracks	 Not Allow	MA	Visual / Microscope	Zone A Zone B
6	Dirty/ foreign body	Allowed if can be removed/ allow	MI	Visual / Microscope	Zone A / Zone B
7	FPC broken/ FPC oxidation / scratch	 Not Allow	MA	Visual / Microscope	Zone B
8	B/W Line	 $L \leq 1.0\text{mm}, W \leq 0.15\text{mm}$ negligible $1.0\text{mm} < L \leq 4.0\text{mm}$ $0.15\text{mm} < W \leq 0.5\text{mm}$ $N \leq 4$ allowable $L > 4.0\text{mm}, W > 0.5\text{mm}$ is not allowed	MI	Visual / Ruler	Zone B
9	TFT edge bulge /TFT chromatic aberration	TFT edge bulge: $X \leq 3\text{mm}, Y \leq 0.3\text{mm}$ Allowed TFT chromatic aberration :Allowed	MI	Visual / Microscope	Zone A Zone B
10	Electrostatic point	$D \leq 0.25\text{mm}$, allow $0.25\text{mm} < D \leq 0.4\text{mm}$, $n \leq 4$ allow $D > 0.4\text{mm}$ is not allowed ($n \leq 8$ items are allowed within 5 mm in diameter)	MI	Visual / Microscope	Zone A
11	PCB damaged/ Poor welding/ Curl	PCB (Circuit area) damaged Not Allow PCB Poor welding Not Allow PCB Curl $\leq 1\%$	MI	Visual / Ruler	Zone B
12	Edge glue height/ Edge glue bubble	Edge Adhesives $H \leq \text{PS surface}$ (Including protect film) Edge adhesives seep in $\leq 1/2$ Margin width Length excluding Edge adhesives bubble: bubble Width $\leq 1/2$ Margin width; Length $\leq 0.5\text{mm}$. $n \leq 5$	MI		
13	Protect film	Surface scratch but not effect protect function, Allow	MI	Visual Inspection	Zone B

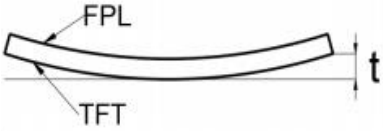
14	Silicon glue	<p>Thickness \leq PS surface(With protect film): Full cover the IC; Shape: The width on the FPC \leq 0.5mm (Front) The width on the FPC \leq 1.0mm (Back) smooth surface, No obvious raised.</p>	MI	Visual Inspection	
15	Warp degree (TFT substrate)	 <p>The diagram shows a cross-section of a curved substrate. The top surface is labeled 'FPL' and the bottom surface is labeled 'TFT'. A vertical dimension line on the right indicates the thickness 't'. Below the diagram, the text reads 't \leq 1.5mm'.</p>	MI	Ruler	
16	Color difference in COM area (Silver point area)	Allowed		Visual Inspection	

16. Packaging

EPD PACKING INSTRUCTION					DATE	
MT-DKE-QS.D-010					DESIGN	
					CHECKED	
					APPROVED	

P/N	Customer Code	Ref. P/N	Type	PKG Method	Printing	Surface Marks	Pull Tape	Bar. Code
MT-DEPG0370			GLASS	Blister	BACK	None	YES	None

<p>Marks instruction:</p> <p style="text-align: center;">print on the back of the product</p> <p style="text-align: center;">Contents: model+Lot#</p>	<p>Pull tape:</p>
---	-------------------

Packing Materials List					10PCS/LAYER, 20LAYER/CTN, TOTAL 200PCS/CTN.	
List	Model	Materials	Q'ty	Unit	Barcode Instruction:	
Carton	7# 417*362*229 mm	corrugate	1	Piece		
BOX	7#(INNER)400*343 *95 mm	corrugate	2	Piece		
Blister	MT-DEPG0370 PET1.0	PET	22	Piece		
Thin foam	305.6*257.0*11.5-1.8 mm	EPE	20	Piece		
Vaccum bag	450*590*0.075		2	Piece		
Foam board	MT-DKE2251-10	EPE	3	Piece		
PULL TAPE	16*5*10.05		200	Piece		

Detail:

<p>Blister box:</p> <p>Note: there are 20 layers of products, divided into 2 inner boxes, and an empty blister box is placed on the top of each inner box, so the number of blister boxes is 22</p> <p style="text-align: center;">QUANTITY: 10PCS</p>	<p>The inner carton shall have one foam board on the bottom layer of each carton and one foam board on the top layer of the outer carton</p> <p>The blister box is rotated for placement</p> <p>INNER BOX LABEL</p> <table border="1" style="width: 100%; border-collapse: collapse;"> <tr><td>型号 (MODEL)</td><td></td></tr> <tr><td>数量 (QUANTITY)</td><td></td></tr> <tr><td>批号 (LOT#)</td><td></td></tr> </table> <p>PUT TWO 7# INNER BOXES INTO 7# CARTON</p> <p>Packing belt</p> <p>rohs Label</p> <p>Shipping marks according to customer's requirements</p> <table border="1" style="width: 100%; border-collapse: collapse;"> <thead> <tr> <th colspan="2">Epaper Identification</th> </tr> </thead> <tbody> <tr> <td>QC:</td> <td>PASS</td> </tr> <tr> <td>Model No.</td> <td></td> </tr> <tr> <td>Quantity.</td> <td>pcs</td> </tr> <tr> <td>Date:</td> <td></td> </tr> <tr> <td>Carton No.</td> <td>of</td> </tr> </tbody> </table>	型号 (MODEL)		数量 (QUANTITY)		批号 (LOT#)		Epaper Identification		QC:	PASS	Model No.		Quantity.	pcs	Date:		Carton No.	of
型号 (MODEL)																			
数量 (QUANTITY)																			
批号 (LOT#)																			
Epaper Identification																			
QC:	PASS																		
Model No.																			
Quantity.	pcs																		
Date:																			
Carton No.	of																		

X-ON Electronics

Largest Supplier of Electrical and Electronic Components

Click to view similar products for [Electronic Paper Displays](#) - ePaper category:

Click to view products by [Microtips](#) manufacturer:

Other Similar products are found below :

[PIM534](#) [E2741JS0B2](#) [EA EPA20-A](#) [DEE 600800A-W](#) [DFR0369](#) [10628](#) [12561](#) [12672](#) [12915](#) [12955](#) [12956](#) [3625](#) [4086](#) [4098](#) [4195](#) [4196](#)
[4197](#) [4243](#) [4262](#) [4777](#) [4778](#) [4814](#) [000026](#) [000041](#) [DEE 400300A2-W](#) [DFR0835](#) [DFR0837](#) [DEE 800480A-W](#) [EA ELABEL20-A](#) [EA](#)
[EPA43-A](#) [EA EPA60-A](#) [28084](#) [E2154CS0C1](#) [E2154JS0C1](#) [E2260CS021](#) [E2266CS0C2](#) [E2266JS0C1](#) [E2271CS021](#) [E2271CS091](#)
[E2271JS094](#) [E2370CS0C1](#) [E2370JS0C1](#) [E2417CS0D1](#) [E2417JS0D1](#) [E2437CS082](#) [E2437CS0C1](#) [E2437JS081](#) [E2581CS0B1](#) [E2581JS0B1](#)
[E2969CS0B1](#)