

Standard specifications

June, 2015



Revision history:

Revision Number:	Revision Date:	Summary of changes:	Authors:
2.00	May, 2015	Thorough revision and redefinition of the standard to encompass add-on boards and sockets.	A.N., S.T., S.M., R.M.
1.00	August, 2011	Initial mikroBUS™ standard, introducing the pinout and the add-on board concept.	A.N.



Index

<i>Revision history</i>	2
<i>Index</i>	3
<i>Introduction</i>	4
<i>mikroBUS™ socket standard</i>	5
<i>Pinout specification</i>	6
<i>Silkscreen markings</i>	7
<i>Placement requirements</i>	9
<i>mikroBUS™ add-on board standard</i>	10
<i>Pinout specification</i>	11
<i>Silkscreen markings</i>	12
<i>Add-on board size and shape</i>	12
<i>Appendix</i>	13
<i>Placement recommendations</i>	14



Introduction

The mikroBUS™ standard defines mainboard sockets and add-on boards used for interfacing microcontrollers or microprocessors [mainboards] with integrated circuits and modules [add-on boards].

The standard specifies the physical layout of the mikroBUS™ pinout, the communication and power supply pins used, the size and shape of the add-on boards, the positioning of the mikroBUS™ socket on the mainboard, and finally, the silkscreen marking conventions for both the add-on boards and sockets.

The purpose of mikroBUS™ is to enable easy hardware expandability with a large number of standardized compact add-on boards, each one carrying a single sensor, transceiver, display, encoder, motor driver, connection port, or any other electronic module or integrated circuit.

Created by MikroElektronika, mikroBUS™ is an open standard — anyone can implement mikroBUS™ in their hardware design, as long as the requirements set by this document are being met.



Socket standard





The mikroBUS™ socket comprises a pair of 1x8 female headers with a proprietary pin configuration and silkscreen markings. The pinout (always laid out in the same order) consists of three groups of communications pins (SPI, UART and I²C), six additional pins (PWM, Interrupt, Analog input, Reset and Chip select), and two power groups (+3.3V and GND on the left, and 5V and GND on the right 1x8 header). The spacing of pins is compatible with standard [100 mil pitch] breadboards.

NOTE: The following pages contain detailed specification on how to implement mikroBUS™ sockets into your hardware design. The easiest way to ensure that your design is in accordance with the prescribed standards, is to use our Altium Designer template files. Download them from:

www.mikroe.com/mikrobus

Pinout specification



Pin functions/silkscreen markings for the socket (see page 11 for how to mark add-on boards)



Silkscreen markings

To preserve the integrity of the mikroBUS™ standard, it's important to always include the mikroBUS™ logo and the default mikroBUS™ pin names on the silkscreen markings. It is preferable to retain the full mikroBUS™ silkscreen markings, but a few alternatives are also permitted.

Full mikroBUS™ silkscreen markings

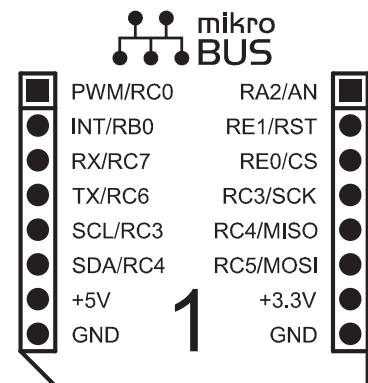
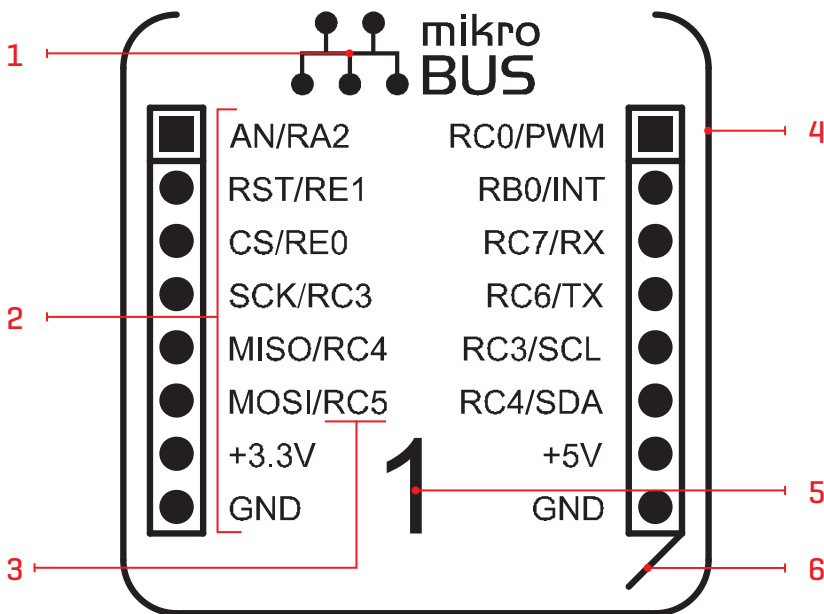

Front view

1. mikroBUS™ logo positioned above the socket
2. Pin names corresponding to the mikroBUS™ standard
3. Pin names corresponding to the routing of the mainboard
4. A line that encloses the socket on all sides except the top, as shown above
5. Socket number, necessary only when multiple sockets are on the same board.
6. A diagonal notch below the right-hand side pinout [serves as a guideline for add-on board insertion]

Rear view

The full mikroBUS™ silkscreen markings also include the print on the backside of the board. While the front of the board often contains a lot of components making it difficult to retain the full markings, the backside rarely has such constraints. Therefore, even when deviating from the full silkscreen markings [see next page], designers are required to retain the markings on the backside.



Alternative front markings positioning

It's not always possible to retain the full silkscreen markings [either because the space between the pins is populated with other components, or the socket is near the edge of the board]. In those cases, designers should follow these guidelines.

1) mikroBUS™ logo

When the logo can't be printed in the default top position, it can be placed:

- A -



In the bottom position

- B -

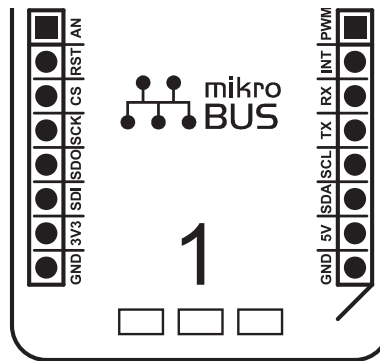

Anywhere in the space between the pins [requires pin names to be printed out vertically]

- C -

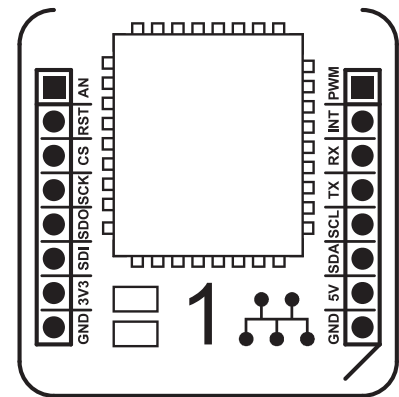

without the mikroBUS™ type – however, the full logo must still be present on the backside of the board.

2) Pin markings

To save space, pin markings can be:

- A -

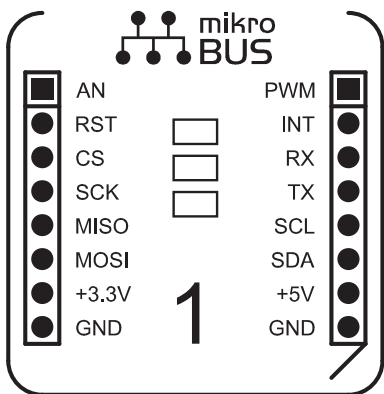

Shortened to include only the default pin names of the mikroBUS™ standard

- B -

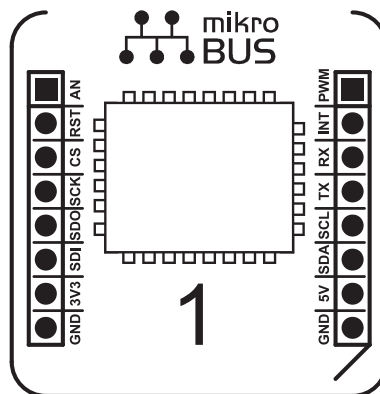

Printed vertically. In this case, MOSI turns into SDO and MISO turns into SDI.

3) Silkscreen outline

The silkscreen outline can also be left out...

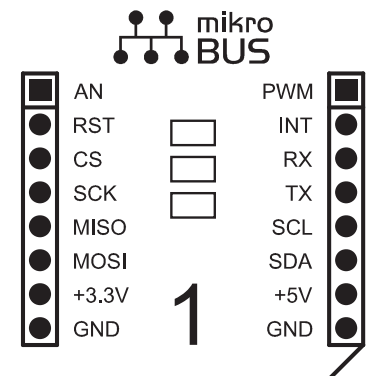

...but the bottom right notch should be preserved because it ensures proper add-on board insertion.



Placement requirements

A mainboard can contain one or more mikroBUS™ sockets. More sockets allow more add-on boards and the number of possible add-on board combinations grows exponentially. The upper limit is imposed by the I/O on the mainboard microcontroller (such considerations are beyond the scope of this standard and are subject to good engineering practises). Adhere to these guidelines when placing sockets:

Dimensions

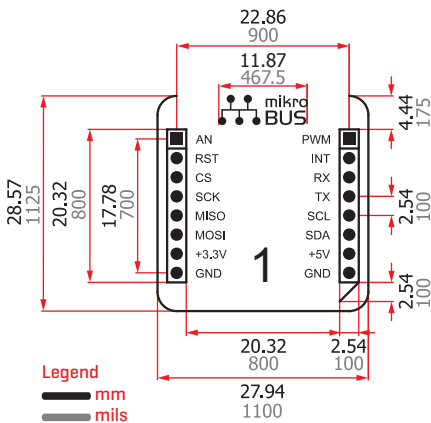

In-line placement

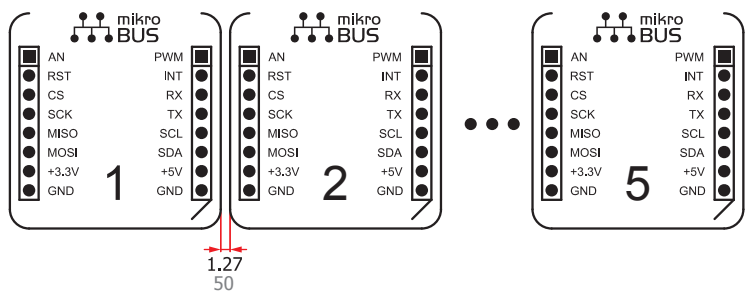

Bottom-to-bottom placement

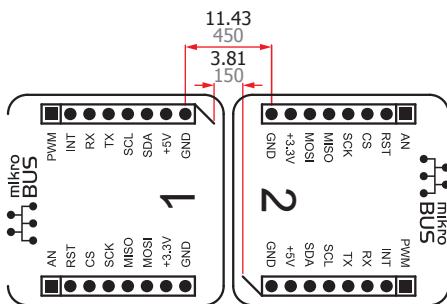

The mikroBUS™ silkscreen markings should be oriented upright relative to the socket — not the entire board. Thus, in the bottom to bottom placement, the socket number and other markings are written out opposite to each other.

Socket numbering

Multiple sockets in two rows should be enumerated in clockwise direction.





Add-on board standard

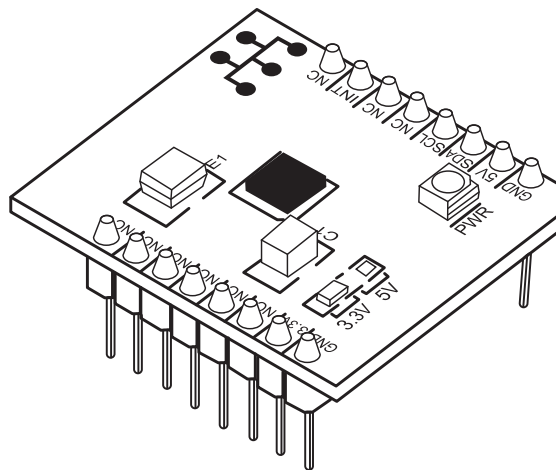



The large number of mutually compatible mikroBUS™ add-on boards is the key value of this standard. Each one carries a single IC or module that brings a specific functionality to a target mainboard. New add-on boards enhance the existing range and provide more choice to end-users. To simplify their use and standardize their appearance, when creating mikroBUS™ add-on boards, designers should adhere to a few requirements in regard to the size, layout and silkscreen markings.

Pinout specification

The pinout on a mikroBUS™ add-on board corresponds with the module, not the target mainboard. As such, some pins are left unused and some deviate from the default configuration as seen on the mikroBUS™ socket. Four cases should be considered.

1. When a module uses an interface already featured on mikroBUS™, use those exact pins and mark them accordingly. This is the default layout:

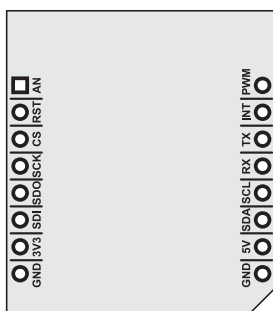

Note the differences: UART markings are criss-crossed because receivers are matched to transmitters. SPI markings are abbreviated. Like so:

sockets	RX	TX	MISO	MOSI
boards	TX	RX	SDO	SDI

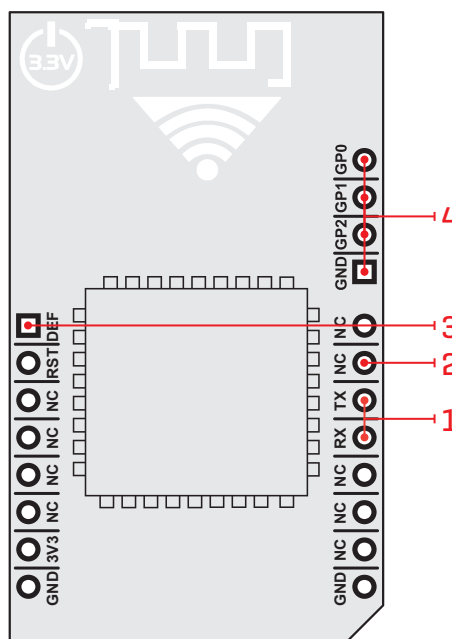

Example add-on board

2. When a pin is not used, it should be marked NC (for Not Connected)
3. When there's no overlap between the name or function of a given mikroBUS™ pin and the pin on the module, the silkscreen should spell the name of the pin from the module. (In this example, DEF is in place of the default AN pin.)
4. Some add-on boards can have a separate pinout in addition to mikroBUS™. These are usually marked by their function, here GPIO.



Silkscreen markings

Required:

1. The add-on board's name on the bottom of the board (front side)
2. Individual pin markings, refer to the pinout section on the previous page
3. Pin markings on the front always printed vertically, to conserve space.
4. Pin markings on the backside of the board printed horizontally, for clarity
5. mikroBUS™ logo anywhere on the board (either front or back)

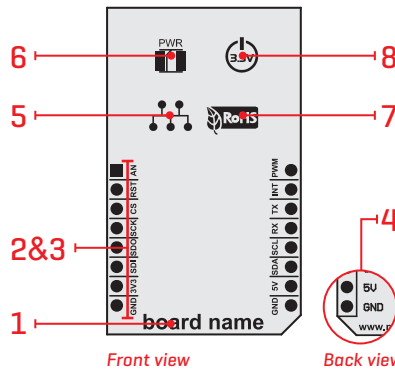

Optional:

6. If space permits, it is good practice to label individual components on the add-on boards (different LEDs, SMD jumpers and similar).
7. If applicable, indicate RoHS, CE, WEE and similar compliance with proper markings.
8. Include an icon to indicate power supply (3.3V, 5V, or both)

click boards™

click boards™ are MikroElektronika's brand of mikroBUS™ add-on boards. The click board™ name is MikroElektronika's trademark. Third party developers are not allowed to call their own mikroBUS™ add-on boards click boards™, nor use the word "click" on the silkscreen. To learn more about click boards™ visit www.mikroe.com/click

Add-on board size and shape

Three sizes are prescribed for mikroBUS™ add-on boards: **S**, **M** and **L**. When designing yours, use the smallest size sufficient to hold a given module. Sensors and transceiver chips will fit on **S** or **M** in most cases. Odd-shaped encoders or larger connectors will require an **L**. Whichever size you use, make sure to retain the **notch** on the bottom right corner of the board (serves as a guide for proper insertion into the socket). Otherwise, you are free to experiment with the shape of the board as long as its confined into these dimensions.

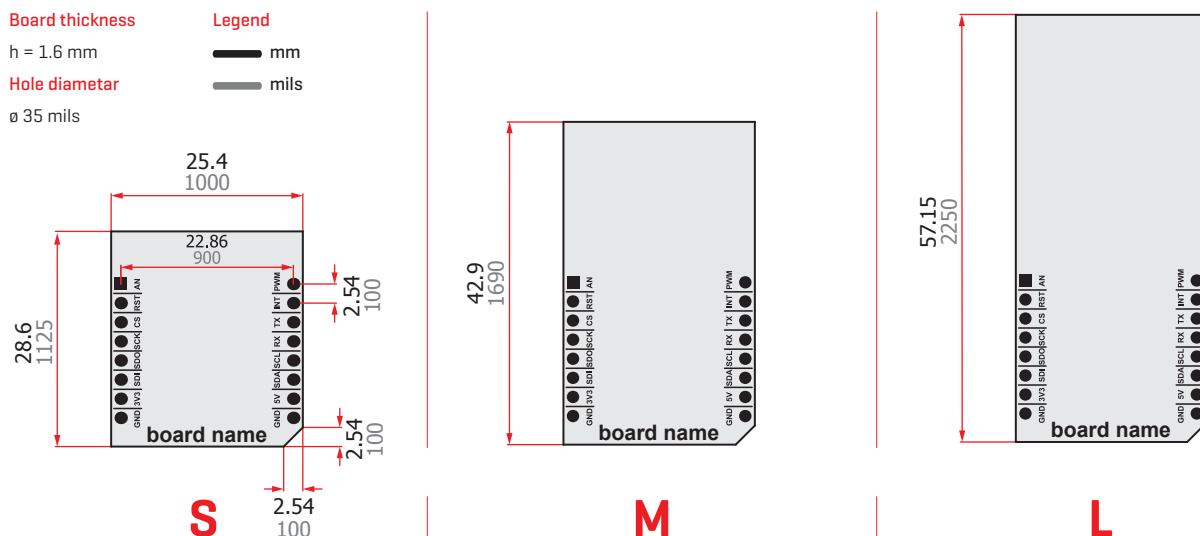



Appendix

Placement recommendations

The mikroBUS™ standard does not dictate the layout of the mainboard beyond the sockets. It's the responsibility of designers to ensure their mainboards are compatible with add-on boards for intended applications. These recommendations are based on a few reoccurring scenarios.

Don't place components that could obstruct M and L sized add-on boards

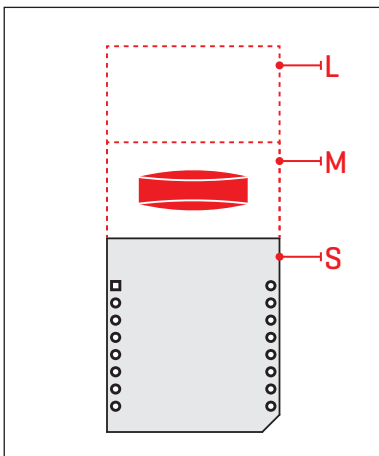

mikroBUS™ add-on boards extend beyond the socket. Placing the socket near tall components like screw terminals, Ethernet ports etc. could pose a barrier to add-on boards.

Don't forget to leave room when enclosing your hardware in a casing

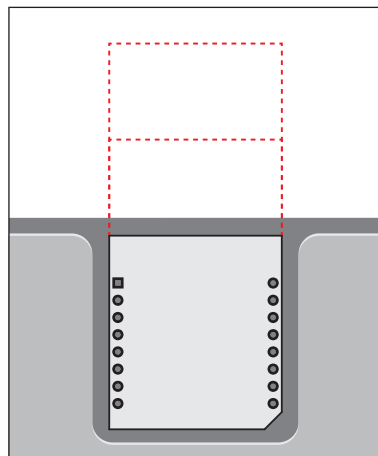

If you plan to enclose the mainboard in a casing, place the sockets so that M and L-sized add-on boards can't protrude beyond the edge of the board.

Don't obscure sensors



On the other hand, keep in mind that add-on boards have various sensors that can work only under proper conditions. For example, sensors intended to measure ambient temperature shouldn't be placed near heat sinks, UV sensors have to be exposed and so on. Evaluate the application of your mainboard and implement sockets accordingly.



If you need additional information about mikroBUS™ or click boards™, place your ticket at www.mikroe.com/support
If you have any questions, comments or business proposals, do not hesitate to contact us at office@mikroe.com

X-ON Electronics

Largest Supplier of Electrical and Electronic Components

Click to view similar products for [Optical Sensor Development Tools](#) category:

Click to view products by [MikroElektronika](#) manufacturer:

Other Similar products are found below :

[416015300-3](#) [ISL29102IROZ-EVALZ](#) [TSL2581CS-DB](#) [TMD3700-DB](#) [NANOUSB2.2](#) [MARS1-MAX9295A-GEVK](#) [MARS1-MAX9296B-GEVB](#) [ISL29112IROZ-EVALZ](#) [TCS3430-DB](#) [AR0130CSSM00SPCAH-GEVB](#) [AR0330CM1C00SHAAH3-GEVB](#) [EVALZ-ADPD2212](#) [TMD2772EVM](#) [TMG3993EVM](#) [MIKROE-2103](#) [TSL2672EVM](#) [1384](#) [SEN0043](#) [SEN0162](#) [TMD2771EVM](#) [TMD3782EVM](#) [TSL4531EVM](#) [1918](#) [AS7225 DEMO KIT](#) [SEN0097](#) [SEN0228](#) [AR0134CSSC00SUEAH3-GEVB](#) [AP0100AT2L00XUGAH3-GEVB](#) [725-28915](#) [SEN-14347](#) [PIEZO-01](#) [MIKROE-3330](#) [MT9M114EBLSTCZD3-GEVK](#) [LF-9MT024NV-EVN](#) [SI1102EK](#) [1334](#) [1356](#) [1777](#) [1980](#) [1981](#) [2748](#) [2899](#) [3779](#) [4162](#) [4698](#) [ALS-GEVB](#) [AS7263 DEMO KIT V3.0](#) [AS7261 DEMO KIT V3.0](#) [AS7264N DEMO KIT](#) [AS7265x Demo Kit Housing](#)