



HoAR 贴片陶瓷系列规格书

系列号	HoAR
修订日期	2019-04-16
版本号	Ho-A0

规格书 Specification



制造商:深圳市毫欧电子有限公司

HoAR

适用: 本规格书适用于深圳市毫欧电子有限公司贴片陶瓷电阻 HoAR 系列产品选型。

包括: HoAR0210/ HoAR0402/ HoAR0603/ HoAR0805/ HoAR1206/ HoAR1210/ HoAR2010/ HoAR2512/

产品特点 Features:

先进的薄膜技术, 高精度低至±0.01%

低温漂 TCR 低至±1PPM /°C

电阻范围 1mR~3MR 微型尺寸 0201 可用 符合 ROHS 要求

产品名称 Product Name

贴片陶瓷电阻

产品型号 Product number

Ho	AR	2512	1/2W	10R	1%	50ppm
供应商	产品系列	封装	额定功率(W)	阻值(mR)	精度(%)	温度系数 TCR (ppm)
Ho 毫欧电子	AR 陶瓷贴片	0201	1/32	49.9R~33KR	0.1%~1%	25~50
		0402	1/16	4.7R~511KR	0.1%~1%	5~50
		0603	1/16	1R~511KR	0.1%~1%	10~50
		0805	1/10	1R~200KR	0.1%~1%	5~50
		1206	1/8	1R~499KR	0.1%~1%	5~50
		1210	1/4	1R~499KR	0.1%~1%	5~50
		2010	1/4	1R~499KR	0.1%~1%	5~50
		2512	1/2	1R~499KR	0.1%~1%	5~50



地址: 深圳市龙华新区观澜大布头路南通邦高新产业园 A 栋 8 楼

■ 产品尺寸 Product Size

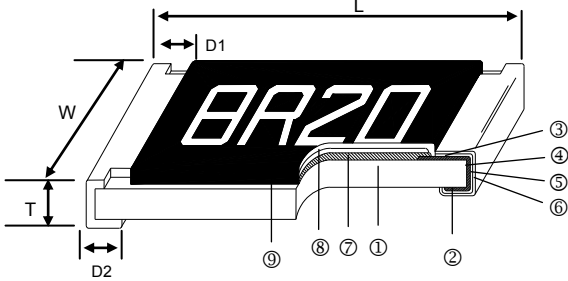
<ol style="list-style-type: none"> 1. Alumina Substrate 2. Bottom Electrode 3. Top Electrode 4. Edge Electrode 5. Barrier Layer 6. External Electrode 7. Resistor Layer 8. Primary Overcoat 9. Secondary Overcoat 					
产品尺寸:					
型号	L(mm)	W(mm)	T(mm)	D1(mm)	D2(mm)
HoAR 0201	0.58±0.05	0.29±0.05	0.23±0.05	0.12±0.05	0.15±0.05
HoAR0402	1±0.05	0.5±0.05	0.30±0.05	0.2±0.1	0.2±0.1
HoAR0603	1.55±0.1	0.8±0.1	0.45±0.1	0.3±0.2	0.3±0.2
HoAR0805	2±0.15	1.25±0.15	0.55±0.1	0.30±0.2	0.4±0.20
HoAR 1206	3.05±0.15	1.55±0.15	0.55±0.1	0.42±0.2	0.35±0.25
HoAR1210	3.1±0.15	2.4±0.15	0.55±0.1	0.4±0.2	0.55±0.25
HoAR2010	4.9±0.15	2.4±0.15	0.55±0.1	0.6±0.3	0.5±0.25
HoAR 2512	6.3±0.15	3.1±0.15	0.55±0.1	0.6±0.3	0.5±0.25

■ 电气参数 Electrical parameter

额定功率 Rated power	1/32~1W
阻值范围 Resistance range	1R~511KR
额定压降 Max. Operating Voltage	15V~400V
准确度等级 AccuracyClass	0.1%、1%
电阻温度系数 T.C.R (ppm / °C)	±5~±50
工作温度范围 Operating Temperature Range	-55°C~+155°C

地址：深圳市龙华新区观澜大布头路南通邦高新产业园 A 栋 8 楼



HoAR 贴片陶瓷系列规格书

系列号	HoAR
修订日期	2019-04-16
版本号	Ho-A0

■ 功率曲线 Power curve

操作温度范围 -55 ~ +155 °C 电阻温度达到 70°C 时降功率示意图



■ 额定电流计算公式 The rated current is calculated by the following Formu

I : Rated Current (A)

P: Rated Power (W)

R: Resistance Value (Ω)

$$I = \sqrt{P/R}$$

■ 标准电气规范 (低阻值) Standard Electrical Specifications (Lower Resistance)

Item Type	Power Rating at 70°C	Operating Temp. Range	Max. Operating Voltage	Max. Overload Voltage	Resistance Range					TCR (PPM/°C)
					±0.05%	±0.1%	±0.25%	±0.5%	±1%	
HoAR0201	1/32W	-55 ~ +155°C	15V	30V	—					±25
								49.9Ω - 4.99KΩ		±50
								49.9Ω - 33KΩ		±50
HoAR(0402)	1/16W	-55 ~ +155°C	25V	50V	49.9Ω - 12KΩ	10Ω - 511KΩ	4.7Ω - 511KΩ			±25,±50
HoAR (0603)	1/16W	-55 ~ +155°C	50V	100V	4.7Ω - 332KΩ	4.7Ω - 1MΩ	1Ω - 1MΩ			±25,±50
HoAR(0805)	1/10W	-55 ~ +155°C	100V	200V	4.7Ω - 1MΩ	4.7Ω - 2MΩ	1Ω - 2MΩ			±25,±50
HoAR (1206)	1/8W	-55 ~ +155°C	150V	300V	4.7Ω - 1MΩ	4.7Ω - 2.49MΩ	1Ω - 2.49MΩ			±25,±50
HoAR(1210)	1/4W									
HoAR(2010)	1/4W	-55 ~ +155°C	150V	300V	4.7Ω - 1MΩ	4.7Ω - 3MΩ	1Ω - 3MΩ			±25,±50
HoAR (2512)	1/2W									

地址：深圳市龙华新区观澜大布头路南通邦高新产业园 A 栋 8 楼



HoAR 贴片陶瓷系列规格书

系列号	HoAR
修订日期	2019-04-16
版本号	Ho-A0

■ 特殊电气规格 Special Electrical Specifications

Item Type	Power Rating at 70°C	Operating Temp. Range	Max. Operating Voltage	Max. Overload Voltage	Resistance Range						TCR (PPM/°C)		
					±0.01%	±0.05%	±0.1%	±0.25%	±0.5%	±1%			
HoAR(0402)	1/16W	-55 ~ +155°C	25V	50V	49.9Ω - 4.99KΩ		-				±1, ±2, ±3		
					49.9Ω - 20KΩ						±5		
					49.9Ω - 20KΩ		49.9Ω - 100KΩ				±10		
							49.9Ω - 69.8KΩ				±15		
HoAR (0603)	1/16W	-55 ~ +155°C	50V	100V	24.9Ω - 15KΩ		-				±1, ±2, ±3		
					24.9Ω - 60KΩ						±5		
					24.9Ω - 100KΩ		4.7Ω - 332KΩ		4.7Ω - 511KΩ				±10, ±15
HoAR(0805)	1/10W	-55 ~ +155°C	100V	200V	24.9Ω - 30KΩ		-				±1, ±2, ±3		
					24.9Ω - 150KΩ						±5		
					24.9Ω - 200KΩ		4.7Ω - 1MΩ				±10, ±15		
HoAR (1206)	1/8W	-55 ~ +155°C	150V	300V	24.9Ω - 49.9KΩ		-				±1, ±2, ±3		
					24.9Ω - 300KΩ						±5		
					24.9Ω - 499KΩ		4.7Ω - 1.5MΩ				±10, ±15		
HoAR (1210)	1/4W	-55 ~ +155°C	150V	300V	24.9Ω - 49.9KΩ		-				±1, ±2, ±3		
					24.9Ω - 300KΩ						±5		
					24.9Ω - 499KΩ		4.7Ω - 1MΩ				±10, ±15		
HoAR (2010)	1/4W	-55 ~ +155°C	150V	300V	24.9Ω - 100KΩ		-				±1, ±2, ±3		
					24.9Ω - 300KΩ						±5		
					24.9Ω - 499KΩ		4.7Ω - 1MΩ				±10, ±15		
HoAR(2512)	1/2W	-55 ~ +155°C	150V	300V	24.9Ω - 100KΩ		-				±1, ±2, ±3		
					24.9Ω - 300KΩ						±5		
					24.9Ω - 499KΩ		4.7Ω - 1MΩ				±10, ±15		

地址：深圳市龙华新区观澜大布头南通邦高新产业园 A 栋 8 楼



HoAR 贴片陶瓷系列规格书

系列号	HoAR
修订日期	2019-04-16
版本号	Ho-A0

■ 高功率等级电气规范 / High Power Rating Electrical Specification

Item Type	Power Rating at 70°C	Operating Temp. Range	Max. Operating Voltage	Max. Overload Voltage	Resistance Range						TCR (PPM/°C)
					±0.01%	±0.05%	±0.1%	±0.25%	±0.5%	±1%	
HoAR (0402)	1/10W	-55 ~ +155°C	50V	100V	49.9Ω - 4.99KΩ			-			±1, ±2, ±3
					49.9Ω - 4.99KΩ						±5
					49.9Ω - 12KΩ			49.9Ω - 60KΩ			±10
								49.9Ω - 69.8KΩ			±15
-	49.9Ω - 12KΩ	10Ω - 255KΩ	4.7Ω ~ 255KΩ			±25, ±50					
HoAR (0603)	1/10W	-55 ~ +155°C	75V	150V	24.9Ω - 15KΩ			-			±1, ±2, ±3
					24.9Ω - 15KΩ						±5
					24.9Ω - 100KΩ	4.7Ω - 332KΩ	4.7Ω - 332KΩ			±10, ±15	
	4.7Ω - 1MΩ			±25, ±50							
1/6W	-55 ~ +155°C	100V	150V	-	10Ω - 332KΩ				±25, ±50		
HoAR(0805)	1/8W	-55 ~ +155°C	150V	300V	24.9Ω - 30KΩ			-			±1, ±2, ±3
					24.9Ω - 30KΩ						±5
					24.9Ω - 200KΩ	4.7Ω - 511KΩ	4.7Ω - 511KΩ			±10	
	4.7Ω - 1MΩ			±15							
1/4W	-55 ~ +155°C	150V	300V	-	10Ω - 499KΩ				±25, ±50		
HoAR (1206)	1/4W	-55 ~ +155°C	200V	400V	24.9Ω - 49.9KΩ			-			±1, ±2, ±3
					24.9Ω - 49.9KΩ						±5
	24.9Ω - 499KΩ	4.7Ω - 1MΩ				±10, ±15, ±25, ±50					
1/3W	-55 ~ +155°C	200V	400V	-	10Ω ~ 1MΩ				±25, ±50		
HoAR(1210)	1/3W	-55 ~ +155°C	200V	400V	24.9Ω - 49.9KΩ			-			±1, ±2, ±3
					24.9Ω - 49.9KΩ						±5
					24.9Ω - 499KΩ	4.7Ω - 1MΩ				±10, ±15, ±25, ±50	
HoAR(2010)	1/3W	-55 ~ +155°C	200V	400V	24.9Ω - 49.9KΩ			-			±1, ±2, ±3
					24.9Ω - 49.9KΩ						±5
					24.9Ω - 499KΩ	4.7Ω - 1MΩ				±10, ±15, ±25, ±50	
HoAR(2512)	3/4W	-55 ~ +155°C	200V	400V	24.9Ω - 2KΩ	4.7Ω - 2KΩ		1Ω - 2KΩ		±10, ±15, ±25, ±50	
	1W	-55 ~ +155°C	200V	400V	-	4.7Ω - 100Ω	1Ω - 100Ω		±25, ±50		

Operating Voltage = $\sqrt{P \cdot R}$ or Max. operating voltage listed above, whichever is lower.
 Overload Voltage = $2.5 \cdot \sqrt{P \cdot R}$ or Max. overload voltage listed above, whichever is lower.

地址：深圳市龙华新区观澜大布头路南通邦高新产业园 A 栋 8 楼

 毫欧电阻 毫欧制造	HoAR 贴片陶瓷系列规格书	系列号	HoAR
		修订日期	2019-04-16
		版本号	Ho-A0

■ 环境特征 Environmental Characteristics

Item	Requirement		Test Method
	Tol. ≤ 0.05%	Tol. > 0.05%	
Temperature Coefficient of Resistance (T.C.R.)	As Spec.		MIL-STD-202 Method 304 +25/-55/+25/+125/+25°C
Short Time Overload	ΔR±0.05%	ΔR±0.2%	JIS-C-5201-1 4.13 RCWV*2.5 or Max. overload voltage whichever is lower for 5 seconds
	ΔR±0.2% for high power rating		
Insulation Resistance	>9999 MΩ		MIL-STD-202 Method 302 Apply 100V _{DC} for 1 minute
Endurance	ΔR±0.05%	ΔR±0.2%	MIL-STD-202 Method 108A 70±2°C, RCWV for 1000 hrs with 1.5 hrs "ON" and 0.5 hrs "OFF"
	>7kΩ ΔR±0.5%		
	ΔR±0.5% for high power rating		
Damp Heat with Load	ΔR±0.05%	ΔR±0.3%	MIL-STD-202 Method 103B 40±2°C, 90~95% R.H. RCWV for 1000 hrs with 1.5 hrs "ON" and 0.5 hrs "OFF"
	ΔR±0.5% for high power rating		
Bending Strength	ΔR±0.05%	ΔR±0.1%	JIS-C-5201-1 4.33 Bending amplitude 3 mm for 10 seconds
Solderability	95% min. coverage		MIL-STD-202 Method 208H 245±5°C for 3 seconds
Resistance to Soldering Heat	ΔR±0.05%	ΔR±0.1%	MIL-STD-202 Method 210E 260±5°C for 10 seconds
Dielectric Withstand Voltage	By Type		MIL-STD-202 Method 301 Max. overload voltage for 1 minute
Thermal Shock	ΔR±0.05%	ΔR±0.2%	MIL-STD-202 Method 107G -55°C ~150°C, 100 cycles
Low Temperature Operation	ΔR±0.05%	ΔR±0.2%	JIS-C-5201-1 4.36 1 hour, -65°C, followed by 45 minutes of RCWV
	ΔR±0.5% for high power rating		
High Temperature Exposure	ΔR±0.5%		MIL-STD-202 Method 108 at +155°C for 1000 hrs

(Rated continuous working voltage)= $\sqrt{P \cdot R}$ or Max. Operating voltage whichever is lower ■

Storage Temperature: 15~28°C; Humidity < 80%RH

- (1) 最高温度260° C下进行回流焊接的时间: 10s
- (2) 最高温度点260° C下波峰焊接的时间: 10s
- (3) 最高温度410°C下烙铁的时间: 5s

回流焊曲线图



波峰焊曲线图



地址: 深圳市龙华新区观澜大布头南通邦高新产业园 A 栋 8 楼

■ 建议焊盘尺寸 Recommended Solder Pad Dimension

型号	A(mm)	B(mm)	C(mm)
HoAR 0201	0.25	0.3	0.4±0.2
HoAR0402	0.5	0.5	0.6±0.2
HoAR0603	0.8	1	0.9±0.2
HoAR0805	1.0	1	1.35±0.2
HoAR 1206	2.0	1.15	1.7±0.2
HoAR1210	2.0	1.15	2.5±0.2
HoAR2010	3.6	1.4	2.5±0.2
HoAR 2512	4.9	1.6	3.1±0.2

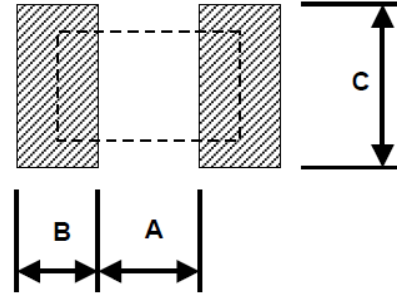

■ 卷轴规格 / 包装方式 Reel Specification / Packing Unit : mm

Type	ØA	ØB	ØC	W	T	Paper Tape (EA)	Emboss Plastic Tape (EA)
HoAR0201	178.0±1.0	60.0±1.0	13.5±0.7	9.5±1.0	11.5±1.0	10,000	-
HoAR0402	178.0±1.0	60.0±1.0	13.5±0.7	9.5±1.0	11.5±1.0	10,000	-
HoAR0603	178.0±1.0	60.0±1.0	13.5±0.7	9.5±1.0	11.5±1.0	5,000	-
HoAR0805	178.0±1.0	60.0±1.0	13.5±0.7	9.5±1.0	11.5±1.0	5,000	-
HoAR1206	178.0±1.0	60.0±1.0	13.5±0.7	9.5±1.0	11.5±1.0	5,000	-
HoAR1210	178.0±1.0	60.0±1.0	13.5±0.7	9.5±1.0	11.5±1.0	5,000	-
HoAR2010	178.0±1.0	60.0±1.0	13.5±0.7	13.5±1.0	15.5±1.0	-	4,000
HoAR2512	178.0±1.0	60.0±1.0	13.5±0.7	13.5±1.0	15.5±1.0	-	4,000

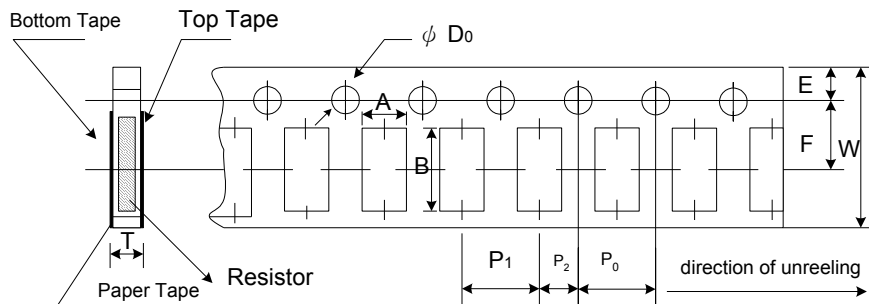
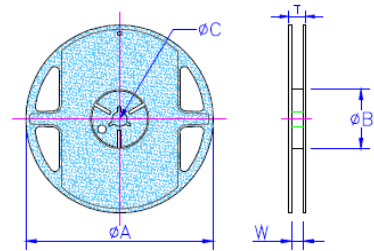

Unit: mm

Type	A	B	W	E	F	P ₀	P ₁	P ₂	ΦD ₀	T
HoAR0201	0.40±0.05	0.70±0.05	8.00±0.10	1.75±0.05	3.5±0.05	4.00±0.10	2.00±0.05	2.00±0.05	1.55±0.03	0.42±0.02
HoAR0402	0.70±0.05	1.16±0.05	8.00±0.10	1.75±0.05	3.5±0.05	4.00±0.10	2.00±0.05	2.00±0.05	1.55±0.05	0.40±0.03
HoAR0603	1.10±0.05	1.90±0.05	8.00±0.10	1.75±0.05	3.5±0.05	4.00±0.10	4.00±0.10	2.00±0.05	1.55±0.05	0.60±0.03
HoAR0805	1.60±0.05	2.37±0.05	8.00±0.10	1.75±0.05	3.5±0.05	4.00±0.10	4.00±0.10	2.00±0.05	1.55±0.05	0.75±0.05
HoAR1206	2.00±0.05	3.55±0.05	8.00±0.10	1.75±0.05	3.5±0.05	4.00±0.10	4.00±0.10	2.00±0.05	1.55±0.05	0.75±0.05
HoAR1210	2.75±0.05	3.40±0.05	8.00±0.10	1.75±0.05	3.5±0.05	4.00±0.05	4.00±0.10	2.00±0.05	1.60±0.10	0.75±0.05

顶盖胶带的剥离力应在8gf至60gf之间

地址：深圳市龙华新区观澜大布头路南通邦高新产业园 A 栋 8 楼

系列号	HoAR
修订日期	2019-04-16
版本号	Ho-A0

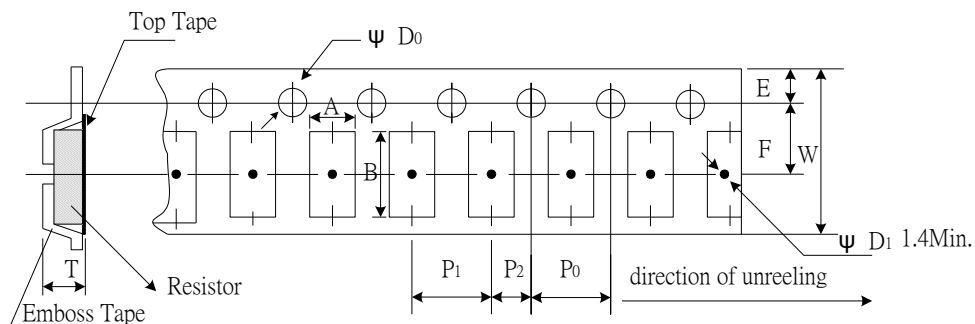

Unit: mm

Type	A	B	W	E	F	P ₀	P ₁	P ₂	∅D ₀	T
HoAR2010	2.85±0.10	5.45±0.10	12.0±0.10	1.75±0.10	5.5±0.05	4.00±0.05	4.00±0.10	2.00±0.05	1.50±0.10	1.00±0.20
HoAR2512	3.40±0.10	6.65±0.10	12.0±0.10	1.75±0.10	5.5±0.05	4.00±0.05	4.00±0.10	2.00±0.05	1.50±0.10	1.00±0.20

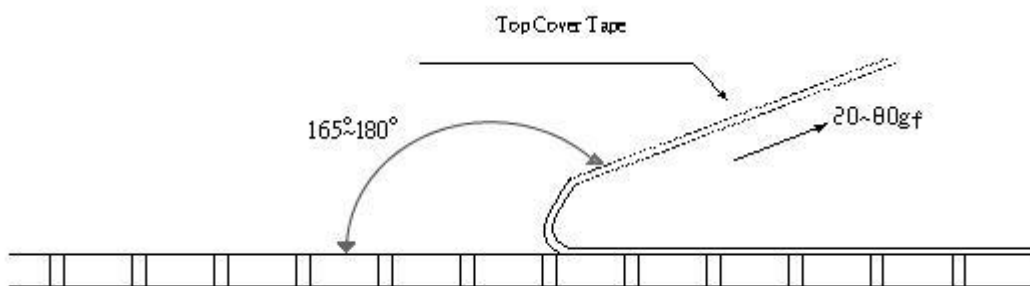

顶盖胶带的剥离力
剥离速度约为300mm / min ± 5%
顶盖胶带的剥离力应在20gf至80gf之间

地址：深圳市龙华新区观澜大布头路南通邦高新产业园 A 栋 8 楼

X-ON Electronics

Largest Supplier of Electrical and Electronic Components

Click to view similar products for [Thick Film Resistors - SMD category](#):

Click to view products by [Milliohm manufacturer](#):

Other Similar products are found below :

[CR-05FL7--150R](#) [CR-05FL7--19K6](#) [CR-05FL7--243R](#) [CR-05FL7--40K2](#) [CR-05FL7--698K](#) [CR-12FP4--324R](#) [CR-12JP4--680R](#)
[M55342K06B1E78RS3](#) [M55342K06B6E19RWL](#) [M55342K06B6E81RS3](#) [M55342M05B200DRWB](#) [M55342M06B4K70MS3](#) [MC0603-511-](#)
[JTW](#) [742C083750JTR](#) [MCR01MZPF1202](#) [MCR01MZPF1601](#) [MCR01MZPF1800](#) [MCR01MZPF6201](#) [MCR01MZPF9102](#) [MCR01MZPJ113](#)
[MCR01MZPJ121](#) [MCR01MZPJ125](#) [MCR01MZPJ751](#) [MCR03EZHJ103](#) [MCR03EZPFX2004](#) [MCR03EZPJ270](#) [MCR03EZPJ821](#)
[MCR10EZPF1102](#) [MCR18EZPJ330](#) [RC0603F1473CS](#) [RC0603F150CS](#) [RC1005F1152CS](#) [RC1005F1182CS](#) [RC1005F1372CS](#)
[RC1005F183CS](#) [RC1005F1911CS](#) [RC1005F1912CS](#) [RC1005F203CS](#) [RC1005F2052CS](#) [RC1005F241CS](#) [RC1005F2431CS](#)
[RC1005F3011CS](#) [RC1005F303CS](#) [RC1005F4321CS](#) [RC1005F4642CS](#) [RC1005F471CS](#) [RC1005F4751CS](#) [RC1005F5621CS](#)
[RC1005F6041CS](#) [RC1005J106CS](#)