

ONLY FOR REFERENCE

Standard Spec Sheet

Mitsumi Model Name	STO-060A24AB
Mitsumi Model No.	R 667996
Operating Force	2.4N
Pcs/Reel	20,000

This specification is only for reference. If you have any questions for the details, please contact SW engineering division.

For your adopting the products, the formal supply specification will be provided.

MITSUMI ELECTRIC CO.,LTD.

2-11-2, Tsurumaki, Tama-shi. Tokyo 206-8657 Japan.

SWITCH ENGINEERING SECTION

1049, Tateiwa, Iizuka-shi. Fukuoka 820-8533 Japan.

00	966L File no.	Specification Tactile switch STO-060A24AB	Approved Feb-27-'18 SW Eng. Ogura	Checked Feb-27-'18 SW Eng. Kikuchi	Drawn Feb-27-'18 SW Eng. Kodama
Customer's name	Customer's parts no.	General specification	Issued Feb-27-'18		
-	-	S66-1823			

- 1) The items specified in this Product specification are prior to General specification.
- 2) The items not specified in this Product specification, General specification is applied.

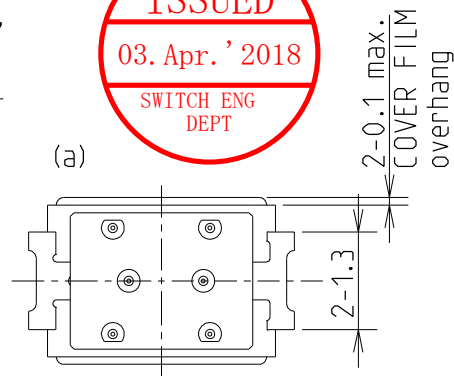
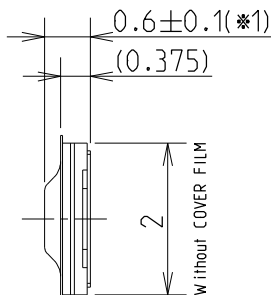
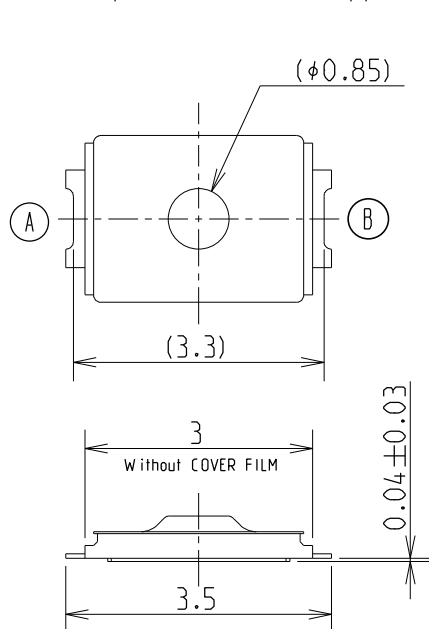

(*1)The switch height shall be measured with applying 5 gf load.

◆ Reference solder stencil dimension

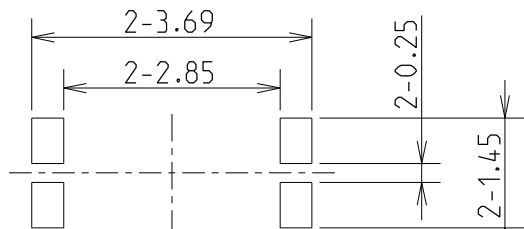

The thickness of solder stencil: 80 μm

◆ Reference land dimension

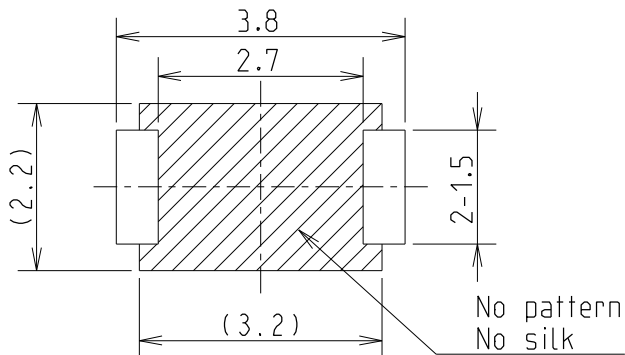

Operating force	2.4+/-0.7 N
Return force	0.2 N min.
Click ratio	40% min.
Travel	0.13+/-0.05 mm
Contact resistance	500 mohm max.
Max. rating	20 mA 15 V DC (Resistive load)
Min. rating	10 μA 2 V DC (Resistive load)
Operating life	500,000 cycles

Circuit diagram

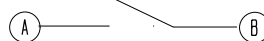

RoHS compliant (2011/65/EU)

Environmental classification	G
Parameter sheet result	N
Development class	2

Rev.					Third angle projection	Scale 10:1	Tolerance +/-0.15	Ass'y dwg. no. 66-K337S
Product.manual	Inspect.manual	Model code	Code	Indent.no.	File no.			
Q66-0861	166-8591	1551	R 66		7996	00		

1823

General specification
Tactile switches
STO series

Approved Mar-23-18 SW Eng. Ogura	Checked Mar-23-18 SW Eng. Kawaguchi	Drawn Mar-23-18 SW Eng. Inoue
Released	Mar-23-18	

1. General

1.1. Application

This specification is applied to Tactile switches named STO series.

1.2. Operating temperature range: -40 to +85 deg-C

1.3. Storage temperature range: -25 to +85 deg-C (Product level)
-20 to +50 deg-C (Taped condition)

1.4. Test conditions

Normal temperature; 5 to 35 deg-C, normal humidity; 45 to 85% RH.

If any doubt arises from judgement, tests and measurements shall be conducted under the following conditions.

Temperature 20+/- 2deg-C, humidity 65+/-5% RH, and air pressure 86 to 106 kPa.



2. Appearance and Construction

2.1. Dimensions: Specified on Product specifications.

2.2. Materials: Refer to Table-1.

2.3. Appearance: There shall be no defects that affect the performance of the products such as crack, scratch, dirt, discoloration, air bubble of ACTUATOR, and contamination.

2.4. Cross section view:

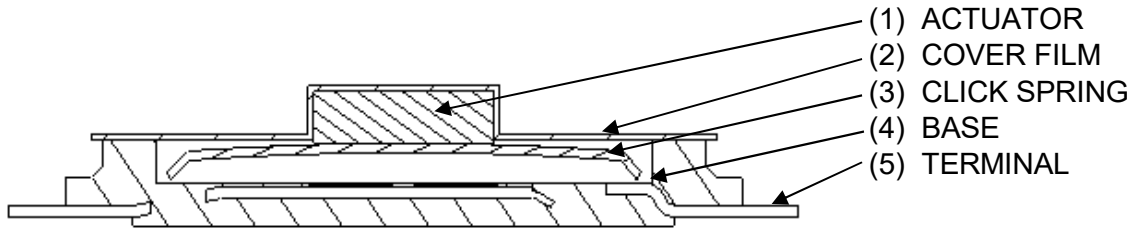

Fig. 1: Cross section of product

Table-1





Components	Material	Note
(1) ACTUATOR	9T Nylon	
(2) COVER FILM	9T Nylon	
(3) CLICK SPRING	Stainless steel	Ag plated
(4) BASE	9T Nylon	
(5) TERMINAL	Phosphor bronze	Ag plated

3. Rating

Specified on Product specification.

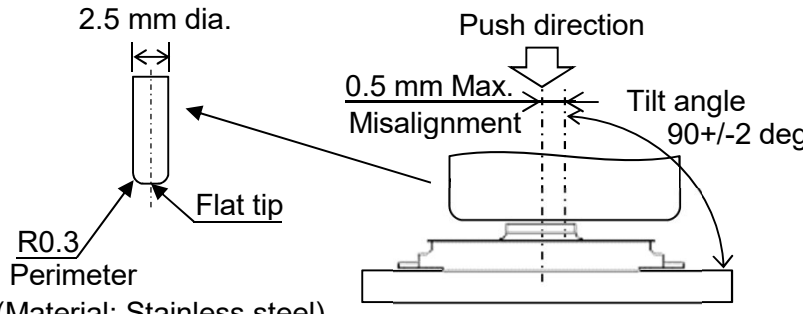
Revision				Code	Division	File No.	
				S	66	1823	

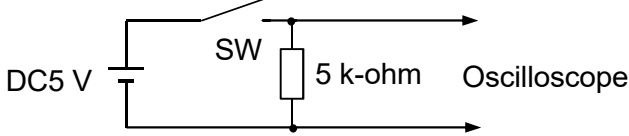

4. Electric Characteristics

Item	Test conditions	Criteria
4.1. Contact resistance	<p>Measurements shall be made under the conditions shown in Fig. 3.</p> <ol style="list-style-type: none"> 1) Load: 2 times of the specified standard operating force. 2) Measurement conditions: Contact resistance meter at 20 mV Max. and 10uA to 10mA.  <p>Fig. 2: Push rod Fig. 3: Measurement conditions</p>	<p>Specified on Product specifications.</p> 
4.2. Insulation resistance	<p>Measurements shall be made under the following conditions.</p> <ol style="list-style-type: none"> 1) Applied voltage: 100 V, DC 2) Duration: 1 min. 3) Applied position: Between terminals. 	50 M-ohm Min.
4.3. Withstanding voltage	<p>Measurements shall be made under the following conditions.</p> <ol style="list-style-type: none"> 1) Applied voltage: 100 V, AC (50/60 Hz) 2) Duration: 1 min. 3) Leak current: 2 mA 4) Applied position: Between terminals. 	There shall be no damage and breakdown.
4.4. Bounce	<p>Measurements shall be made under the conditions shown in Fig. 3.</p> <p>Bounce time at "ON" and "OFF" shall be measured under the following conditions.</p> <ol style="list-style-type: none"> 1) Circuit: Refer to Fig. 4. 2) Load: 1.5 times of the specified standard operating force. 3) Frequency of operation: 3 to 4 times/sec.  <p>Fig. 4: Circuit</p>  <p>Fig. 5: Bounce</p>	<p>ON bounce: 10 ms Max.</p> <p>OFF bounce: 10 ms Max.</p>

File number

1823

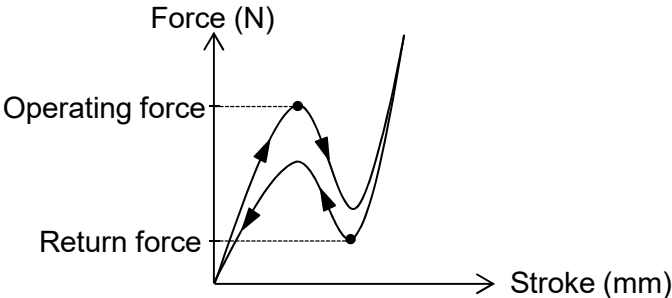
5. Mechanical Characteristics

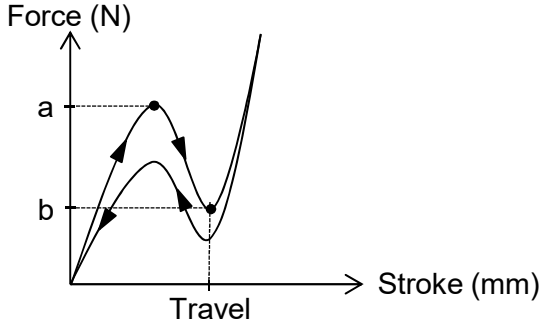
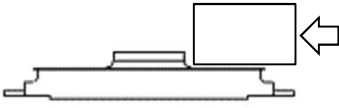
Item	Test conditions	Criteria
5.1. Operating force 5.2. Return force	Measurements shall be made under the conditions shown in Fig. 3 just after striking 10 times lightly. 1) Measurement speed: 0.5 mm/sec. 2) Limit load to apply: 1.5 to 2 times of the specified standard operating force.  Fig. 6: Force-Stroke curve	Specified on Product specifications. 
5.3. Click ratio 5.4. Travel	Refer to 5.1 and 5.2 for the measurement conditions. Click ratio = $(a - b) / a \times 100\%$  Fig. 7 Force-Stroke curve	Specified on Product specifications.
5.5. Stopper strength	Measurements shall be made under the conditions shown in Fig. 3 and at returned condition. Load: 50 N Duration: 15 sec.	There shall be no electrical and mechanical abnormality.
5.6. Shear strength	Measurements shall be made just after applying static load under the following conditions. 1) Load: 3 N 2) Duration: 15 sec. Test shall be made after two times of reflow soldering.  Fig. 8: Shear strength test	

File number

1823

5. Mechanical Characteristics

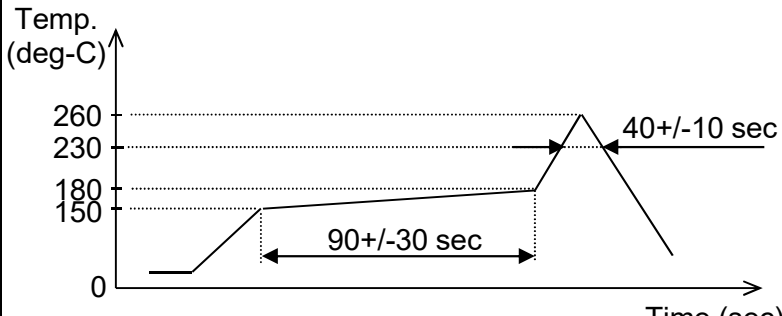
Item	Test conditions	Criteria
5.7. Vibration resistance	Measurements shall be made after testing under the following conditions. 1) Vibration frequency range: 10 to 55 Hz 2) Amplitude: 1.5 mm (peak-to-peak) 3) Sweep ratio: 10-55-10 Hz in approx. 1 min. 4) Frequency sweep mode: Logarithmic or Liner sweep 5) Direction of vibration: 3 orthogonal directions including the direction of operation. 6) Duration: 2 hr each (6 hr in total)	There shall be no electrical and mechanical abnormality. 
5.8. Impact resistance	Measurements shall be made after testing under the following conditions. 1) Acieration: 735 m/s ² 2) Duration: 6 msec 3) Test direction: 6 directions 4) Number of test: 3 times per direction (18 times in total)	There shall be no electrical and mechanical abnormality.
5.9. Solderability	Measurements shall be made under the following conditions. 1) Solder temperature: 230 +/- 5 dig-C 2) Dipping time: 3 +/- 0.5 sec. 3) Composition of solder: Sn-3.0Ag-0.5Cu 4) Soldering flux: Rosin 25%, Alcohol 75%	More than 75% of dipped part shall be covered with solder.
5.10. Soldering heat resistance	Measurements shall be made after reflow soldering under the following conditions. 1) Heating method: Far-infrared radiation heating 2) Temperature profile: As shown in below. 3) Allowable soldering process: 2 times Max.  Fig. 9: Reflow soldering profile	There shall be no abnormality such as marked looseness, drop-off, and assured 4. Electrical Characteristics. Operating force: Item 5.1.

5.11. Precautions for soldering

- 1) This product is designed for reflow soldering. Please do not solder manually.
- 2) Do not wash the product with solvent or the like.
- 3) The soldering conditions will be different depending on reflow soldering machines. Conditions of soldering shall be confirmed under actual production conditions.
- 4) Reflow soldering shall be performed in shorter time and at lower temperature. Otherwise click ratio may be decreased.
- 5) Please set the proper volume of solder in order to prevent soldering flux ingress and float of the products.
- 6) Please do not apply soldering flux to the terminals and mounting surface of PWB/FPC.
- 7) Note that if the load is applied to the terminals during soldering it might cause deformation and defects in electrical performance.

File number

1823

6. Durability

Item	Test conditions	Criteria
6.1. Operating life	<p>Measurements shall be made after testing under the following conditions.</p> <ol style="list-style-type: none"> 1) Electrical load: Rated load or no load. 2) Rate of operation: 2 cycles/sec. 3) Depression: The maximum value of specified operating force. 4) Cycles of operation: Specified on the product specification. 	<p>Contact resistance: 20 ohm Max.</p> <p>Bounce (ON/OFF): 20 msec Max.</p> <p>Operating force: Within +/-30% of specified initial value.</p> <p>Insulation resistance: 10 M-ohm Min.</p> <p>Withstanding voltage: Item 4.3.</p> <p>Travel: Item 5.4.</p>



7. Environmental

Item	Test conditions	Criteria
7.1. Humidity resistance	<p>Following the test set forth below the sample shall be left in normal temperature and humidity conditions for 1 hr before measurements are made.</p> <p>Water drops shall be removed.</p> <ol style="list-style-type: none"> 1) Temperature: 65+/-2 deg-C, Humidity: 90 to 96% RH 2) Duration: 96+/-5 hr 	<p>Contact resistance: 1 ohm Max.</p> <p>Insulation resistance: 10 M-ohm Min.</p>
7.2. Heat resistance	<p>Following the test set forth below the sample shall be left in normal temperature and humidity conditions for 1 hr before measurements are made.</p> <ol style="list-style-type: none"> 1) Temperature: 85+/-3 deg-C 2) Duration: 96+/-5 hr 	<p>Withstanding voltage: Item 4.3.</p>
7.3. Cold resistance	<p>Following the test set forth below the sample shall be left in normal temperature and humidity conditions for 1 hr before measurements are made.</p> <p>Water drops shall be removed.</p> <ol style="list-style-type: none"> 1) Temperature: -40+/-3 deg-C 2) Duration: 96+/-5 hr 	<p>Bounce (ON/OFF): 20 msec Max.</p> <p>Operating force: Within +/-30% of specified initial value.</p> <p>Travel: Item 5.4.</p>

File number

1823

7. Environmental

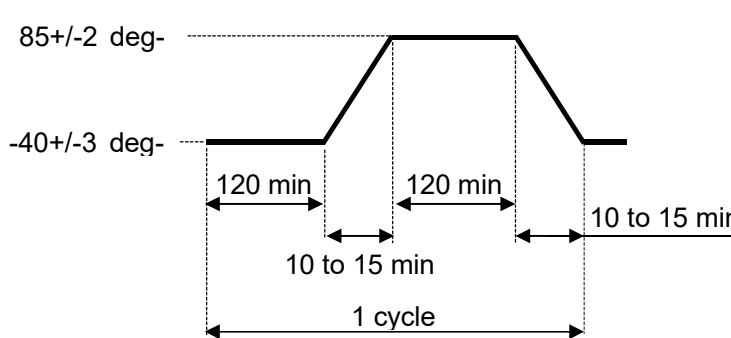
Item	Test conditions	Criteria
7.4. Temperature cycling	<p>Following continuous 5 cycles of the temperature cycling test set forth below, the sample shall be left in normal temperature and humidity conditions for 1hr before measurements are made.</p>  <p>Fig. 10: Temperature cycling test conditions</p>	<p>Contact resistance: 1 ohm Max.</p> <p>Insulation resistance: 10 M-ohm Min.</p> <p>Withstanding voltage: Item 4.3.</p> <p>Bounce (ON/OFF): 20 msec Max.</p> <p>Operating force: Within +/-30% of specified initial value.</p> <p>Travel: Item 5.4.</p>
7.5. Water resistance IPX7 equivalent	<p>Ingress shall be confirmed after the test under the following conditions based on IPX7.</p> <ol style="list-style-type: none"> 1) Depth of immersion: 1 m 2) Duration of immersion: 30 min. 	<p>There shall be no ingress water inside of the product.</p>
7.6. Dust protection IP6X equivalent	<p>Ingress shall be confirmed after the test under the following conditions based on IP6X.</p> <ol style="list-style-type: none"> 1) Temperature: 15 to 35 deg-C(Normal temperature) Humidity: 25 to 75% RH(Normal humidity) 2) Air pressure 86 to 106 kPa. 3) Amount of tarc:2 kg/m³ , Tarc:JIS Z8901-4 4) Time: 8hours 	<p>There shall be no ingress dust inside of the product.</p>



8. Use Condition

- 8.1. Operating temperature range: Refer to the item 1.2.
(Temperature range which the product is ON and OFF electrically.)
There shall be no freezing and condensation.

8.2. Using environment

- 1) Do not expose the products to corrosive gas such as sulfur gas and salty wind.
- 2) Visible dust must be cleared.
- 3) Please do not apply excessive load to the products to avoid deformation and deterioration.

9. Storage Condition

- 9.1. Storage temperature range: Refer to the item 1.3. There shall be no freezing and condensation.

9.2. Environment

- 1) Do not expose the products to corrosive gas such as sulfur gas, and salty wind.
- 2) Visible dust must be cleared.
- 3) Please do not apply excessive load to the products to avoid deformation and deterioration.

File number

1823

9.3. Storage method

- 1) Products shall be packed in an airtight plastic bag and stored in cool place avoiding direct sunshine.
- 2) Do not stack too many switches for strafe. Shall be free from high temperature and high humidity.
- 3) Do not store the products in the state of applying load on it's operation area.
- 4) Products should be used within six months after the date of delivery.

10. Precautions in Use

- 10.1. Do not clean the products with a solvent or the like.
- 10.2. Do not use the products with beyond the rated current and voltage.
- 10.3. Do not apply excessive load to the terminals and the operating part.
- 10.4. Larger static load than specified and/or shock shall not be applied to the operating part.
- 10.5. After mounting the products on PWB/FPC, please do not stack too many PWB/FPC in order to avoid excessive load to the switch mounted area.
- 10.6. The dimensions of a pattern on PWB/FPC shall refer to the recommended dimensions in Product specifications.
- 10.7. If you use this product in one of the following environmental conditions, progress of sulfuration and oxidization on the contact part (silver) will be accelerated, which may cause contact failure.
Therefore, be careful about the operation environment.
 - 1) Around a sulfarate hot spring where sulfide gas is generated.
 - 2) In case this product is always used in a place where exhaust gas from automobiles exist.
- 10.8. Do not push the cover film of products with something sharp.
- 10.9. Please design and assemble your unit not to apply over load to the switch.
- 10.10. Please let us know beforehand if you use other shape of pushing rod than the shape described in Fig. 2.
- 10.11. Please be careful on designing and handling especially when the switch is being built into the unit, not to add side force (static or impact) to the ACTUATOR as shown below (Fig. 11), because the ACTUATOR might deform or come off.

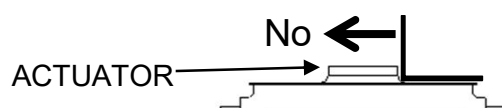

Fig. 11 Load and impact from side direction



- 10.12. Unless provided for otherwise, the products have been designed and manufactured for application in equipment and devices which are sold to end users in the market, including audio-visual equipment, electrical home appliances, office machines, information and communication equipment, and amusement equipment.
The products are not intended for use in, and must not be used for, any application for nuclear equipment, driving equipment for aerospace or any other unauthorized use. With the exception of the abovementioned prohibited applications, please contact us (MITSUMI) and/or evaluate the total system regarding applicability for applications involving high levels of safety and liability such as medical equipment, burglar alarm equipment, disaster prevention equipment and undersea equipment. Please also incorporate fail-safe design, protection and redundant circuitry, malfunction protection, and/or fire protection into the complete system to ensure safety and reliability of the total system.
- 10.13. If you intend to use the products for automotive, please let us know beforehand.

File number

1823

11. Packing Specification

11.1. Dimensions of carrier tape are as shown below.

11.2. Taping rule

- 1) Tape winding direction is in clockwise.
(When pulling the tape toward, feeding holes should be located on the right side.)
- 2) Feeding holes shall not be covered with the cover tape.
The cover tape shall not be run off the edge of the carrier tape.
- 3) 160 mm or more from the end of trailer tape part shall be empty.
- 4) The leader part shall be 400 mm or more and it should include 100 mm of empty part.
The leader part shall have 20 to 30 mm of un-sealed cover tape.
- 5) The top tape of the leader part shall be stuck on the side of the reel by 30 to 50 mm using adhesive tape.
- 6) Peeling strength of cover tape from carrier tape is 0.1 to 1.3 N at 165 to 180 deg.
- 7) QR-code label and Mitsumi label shall be stuck on the side of the reel.
- 8) The products shall free drop from the reversed carrier tape without cover tape after pressing at 0.1 to 0.2 N force.
- 9) Continuous two missing switches shall not be allowed.
Total number of missing switches shall be 0.1% or less of the packed quantity per reel.
- 10) The direction of products in the pockets is not specified.
- 11) 20,000 switches shall be packed in a reel.

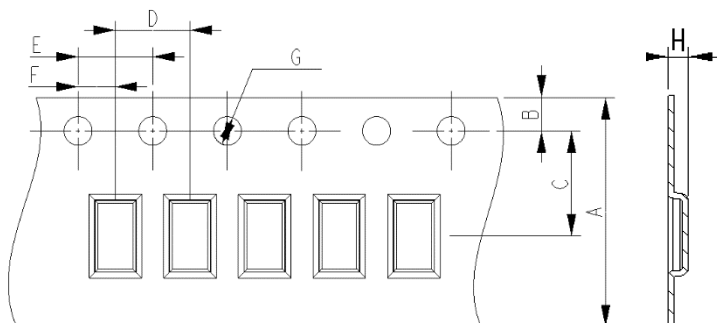

A	B	C	D	E	F	G	H
12	1.75	5.5	4+/-0.1	4+/-0.1	2	1.5 dia +0.1/-0	1

Fig. 12 Carrier tape dimensions

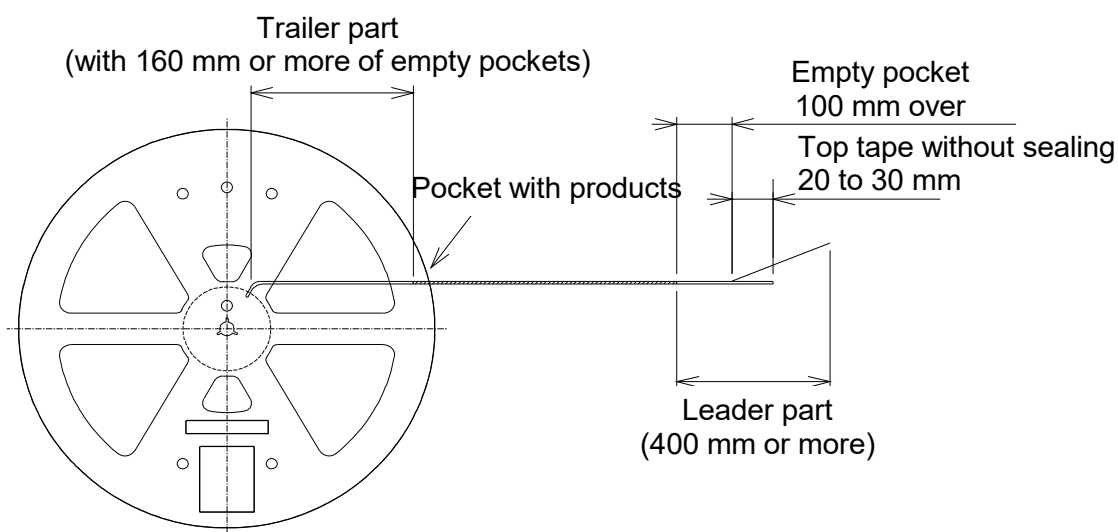

Fig. 13 Taping specification

File number

1823

12. Packing Specification

1) Inner packing specification

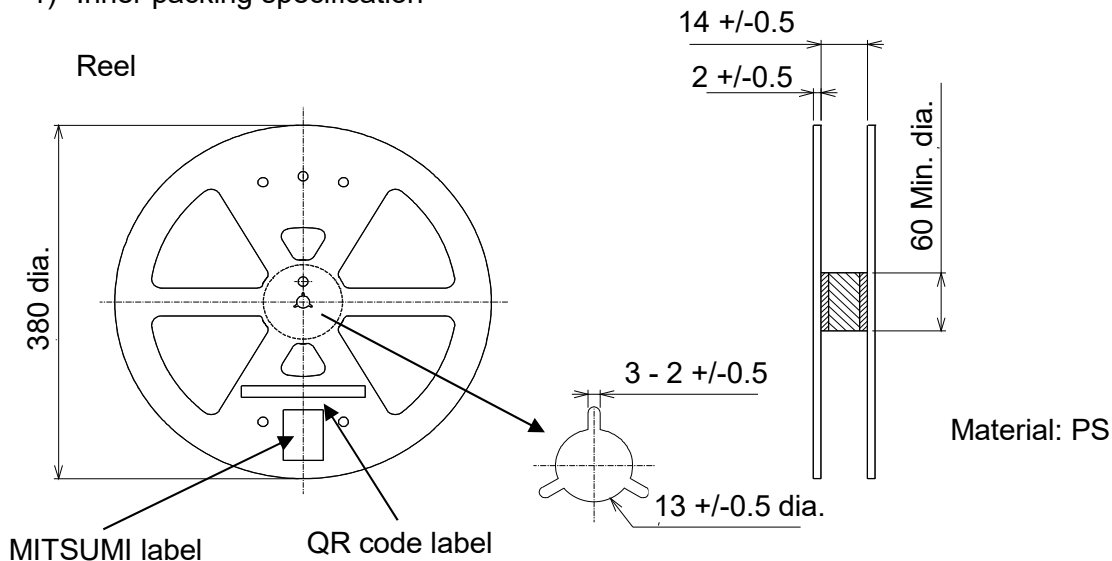

2) Outer box specification

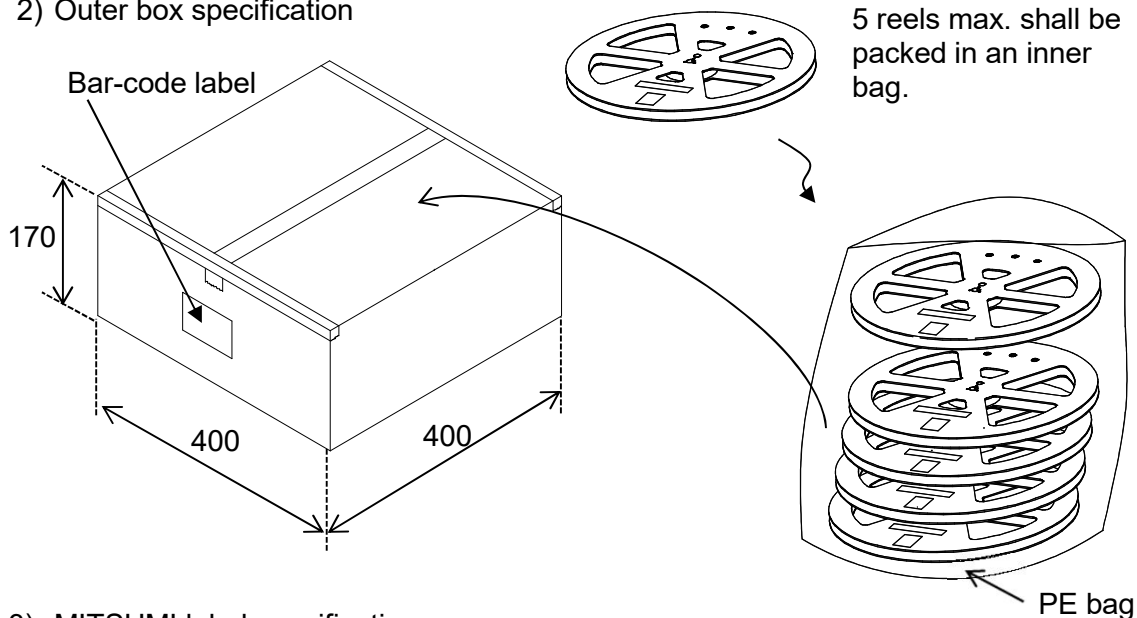

3) MITSUMI label specification

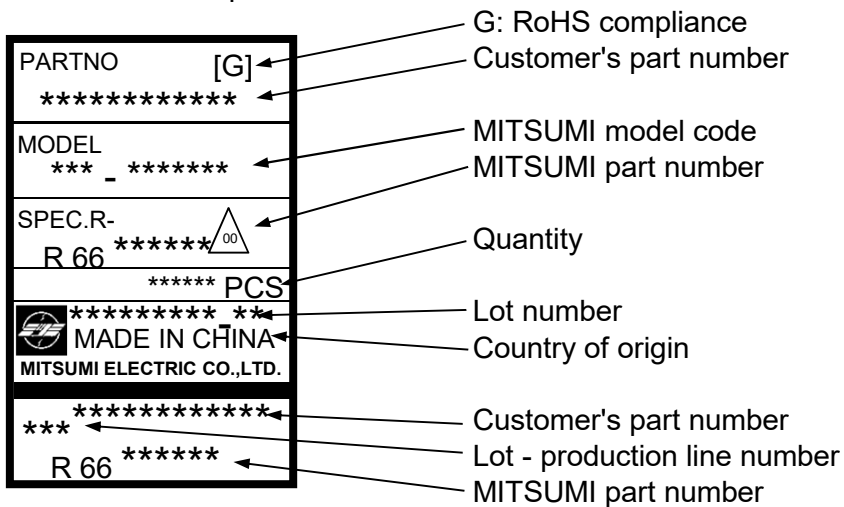

File number
1823

X-ON Electronics

Largest Supplier of Electrical and Electronic Components

Click to view similar products for [Tactile Switches](#) category:

Click to view products by [MinebeaMitsumi](#) manufacturer:

Other Similar products are found below :

[6407-250V-25273P](#) [ADTSA62NV](#) [B3F-3123](#) [1977177-8](#) [1977266-1](#) [ADTSA63NV](#) [ADTSM21NSVTR](#) [ADTSM25RVTR](#) [ADTSM32NVTR](#)
[ADTSMW64RV](#) [1977120-6](#) [FSMRA4JHA04](#) [GS4.70F300QP](#) [KSC241J SP DELTA LFS](#) [3FTL600RAS](#) [3FTL640RAS](#) [6407-250V-25343P](#)
[ADTSM31NVTR](#) [2-1977120-7](#) [TSJW-5.2-260-TR](#) [Y651050400P](#) [KMT011MNGJLHS](#) [70-201.0](#) [ADTSG648NV](#) [ADTSM62KSVTR](#)
[ADTSM648NV](#) [95C06E3RAT](#) [3ATH9Q](#) [FSMRA8JHA04](#) [HARS0073](#) [Y33R411N9FPLFT](#) [Y33R51139FPLFT](#) [Y31C01402FPLFS](#)
[PTS645SK50SMTR92](#) [ADTSM32NVB](#) [KMS233GPWTLFG](#) [Y78B64124FP](#) [Y31CJ244KFP LFS](#) [Y96D113G0FP LFS](#) [Y33A812C5FP LFT](#)
[Y56B2D120FP LFS](#) [Y31C5144KFP LFS](#) [PTS645 DVM83-BN125-2 LFS](#) [B3W 1000G](#) [KSC621G OL LFS](#) [B3F 1002C](#) [B3F 0047H](#) [B3W](#)
[1002C](#) [B3F 5001G](#) [B3W 1100C](#)