

PRODUCT DESCRIPTION



MD7673 series are highly accurate, low-noise, high power supply rejection ratio (PSRR), low-dropout voltage regulator (LDO) with high output current capability manufactured in CMOS processes. It can deliver up to 3A of current while consuming 40µA of quiescent current. Internal circuitry includes a reference voltage generator, an error amplifier, driver transistor, over-current protection circuit, short-circuit protection circuit, thermal shutdown circuit and a phase compensation circuit. The MD7673 operates by default as a fixed output voltage regulator (default output voltage: 5V) while usage of an external resistor divider allows adjustable out voltages as low as 0.7V. Additional features include enable function, power good flag and output noise reduction pin.

FEATURES

- Highly Accurate: ±2%
- Low Quiescent Current: 40µA
- Dropout Voltage: 480mV@3.3V/3A (TO263-5L)
- Maximum Output Current: 3A
- Input Voltage Range: 2~6V
- Output Voltage Noise: 115µVrms@V_{OUT}=3.3V
- High PSRR: 70dB@1kHz
- Temperature Stability: ±50ppm/°C
- ON/OFF Logic = Enable High
- Power Good and Enable Functions
- Standby Current: 10nA
- C_{OUT} Discharge Circuit when EN Disable is Active
- Protections Circuits: Current Limit, Short Circuit, and Thermal Protections
- Output Capacitor: Low ESR Ceramic Capacitor Compatible
- RoHS compliant “Green”/Halogen Free 8-pin Exposed pad SOIC (ESOP8), 5-pin TO263 and 4-pin TO252 packages

APPLICATIONS

- Smart wearer
- Long-life battery-powered devices
- Portable mobile devices, such as mobile phones, cameras, and so on
- Wireless communication equipment

TYPICAL APPLICATION CIRCUIT:

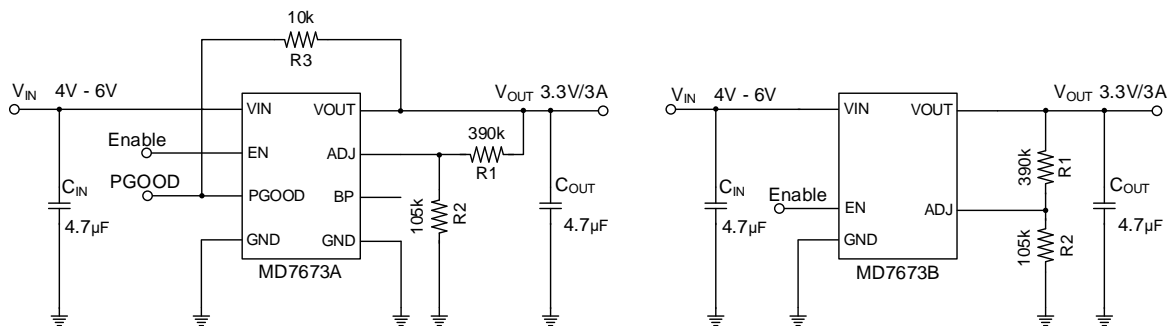

PIN CONFIGURATION (TOP VIEW)

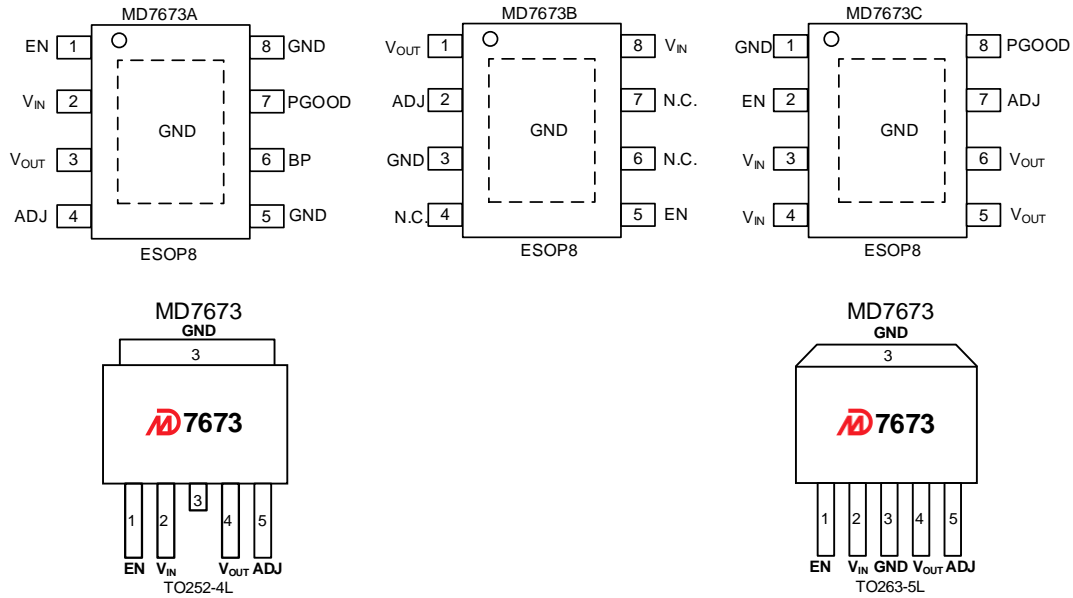

PRODUCT SELECTIONS

Type	Fixed Output Voltage (note 1*)	ADJ	Accuracy (note 2*)	Package (note 3*)	MARKING (note 4*)
MD7673A50SF4	5V	Yes	±2%	ESOP8	7673A
MD7673B50SF4	5V	Yes	±2%	ESOP8	7673B
MD7673C50SF4	5V	Yes	±2%	ESOP8	7673C
MD7673E50UB2	5V	Yes	±2%	TO252-4L	7673
MD7673E50VC1	5V	Yes	±2%	TO263-5L	7673

Notes:

1* Customer can request to customize the output voltage ranged from 1.2V to 5V if desired voltage is not found in the selections.

2* Customer can request customization of accuracy requirement.

3* Customer can request customization of package choice.

4* Please pay attention to the MARKING of the product package type.

PIN DESCRIPTION

Name	ESOP8 (MD7673A)	ESOP8 (MD7673B)	ESOP8 (MD7673C)	TO252-4L (MD7673)	TO263-5L (MD7673)	Description
VOUT	3	1	5,6	4	4	Regulator Output pin.
ADJ	4	2	7	5	5	Adjustable Pin. Output Voltage can be set by external feedback resistors when using a resistive divider. Or, connect ADJ to GND for $V_{OUT} = 5V$, set by internal feedback resistors.
GND	5,8	3	1	3	3	Ground Signal
EN	1	5	2	1	1	Enable Pin. Minimum 1.6V to enable the device. Maximum 0.4V to shutdown the device.
VIN	2	8	3,4	2	2	Power Input Pin. Must be closely decoupled to GND pin with a 4.7 μ F or greater ceramic capacitor.
BP	6	-	-	-	-	Bypass pin. Connect a 1 μ F capacitor to GND to reduce output noise. Bypass pin can be left floating if unnecessary.
PGOOD	7	-	-	-	-	Power Good open Drain Output
N.C.	-	4,6,7	8	-	-	None Connection (Used to connect GND or OPEN state.)
GND	Exposed Pad	Exposed Pad	Exposed Pad	-	-	Connect to GND.

ABSOLUTE MAXIMUM RATINGS

(Unless otherwise indicated: Ta=25°C)

PARAMETER	SYMBOL	RATINGS	UNITS
Input Voltage	V_{IN}	-0.3 ~ 7	V
Output Voltage	V_{OUT}	-0.3 ~ $V_{IN}+0.3$	
Power Dissipation	P_D	Internally Limited	
Thermal Resistance	$R_{\theta JB}^{(1)}$	ESOP8	80
		TO252-5L	60
		TO263-5L	50
Operating Ambient Temperature	T_{opr}	-40 ~ +85	°C
Storage Temperature	T_{stg}	-40 ~ +125	
ESD Protection	ESD HBM	4000	V

Note: Stresses above those listed under "Absolute Maximum Ratings" may cause permanent damage to the device.

(1) Mounted on JEDEC standard 4layer (2s2p) PCB test board

3A 5V-Adjustable Low Dropout Voltage Regulator

ELECTRICAL CHARACTERISTICS

Unless otherwise indicated, $V_{IN} = V_{OUT} + 1V$, $C_{IN} = 4.7\mu F$, $C_{OUT} = 4.7\mu F$, $C_{BYP} = 1\mu F$, $T_J = 25^\circ C$.

PARAMETER	SYMBOL	CONDITIONS	MIN.	TYP.	MAX.	UNIT
Input Voltage	V_{IN}		2		6	V
Output Voltage Tolerance	$V_{OUT(S)}$	$I_{OUT} = 1mA$	-2		+2	%
Continuous Output Current	I_{OUT}	$V_{IN} > 2.3V$	3			A
Ground Current	I_{GND}	$V_{EN} = V_{IN}$, no load		40		μA
		$V_{EN} = V_{IN}$, $I_{OUT} = 100mA$		390		
Shutdown Current	I_{SHUT}	$V_{EN} = 0$		0.01		μA
Output Current Limit	I_{LIM}			4		A
Current Fold Back				1		
Dropout Voltage*2	V_{DROP}	$V_{EN} = V_{IN}$, $I_{OUT} = 3A$, $V_{OUT} = 1.8V$		660	850	mV
		$V_{EN} = V_{IN}$, $I_{OUT} = 3A$, $V_{OUT} = 3.3V$		480	600	
		$V_{EN} = V_{IN}$, $I_{OUT} = 3A$, $V_{OUT} = 5V$		460	580	
Line Regulation		$V_{OUT(S)} + 1V \leq V_{IN} = V_{EN} \leq 6V$ $I_{OUT} = 1mA$		3	15	mV
Load Regulation	ΔV_{OUT2}	$V_{IN} = V_{EN} = V_{OUT(S)} + 1.0V$ $1mA \leq I_{OUT} \leq 3A$		10	20	mV
Temperature Stability	$\frac{\Delta V_{OUT}}{\Delta T_a \cdot V_{OUT}}$	$V_{IN} = V_{EN} = V_{OUT(S)} + 1.0V$ $I_{OUT} = 1mA$ $-40^\circ C \leq T_A \leq 125^\circ C$		± 50		ppm/ $^\circ C$
Reference Voltage Tolerance			0.686	0.7	0.714	V
ADJ Pin Current		$V_{ADJ} = V_{REF}$		10		nA
ADJ Pin Threshold			0.05	0.1	0.2	V
Enable Turn-On Threshold		Output ON	1.6			V
Enable Turn-Off Threshold		Output OFF			0.4	V
Shutdown Pin Current				0.1	0.5	μA
Shutdown Exit Delay Time				0		μs
Max Output Discharge Resistance to GND during Shutdown				30		Ω
PGOOD Rise Threshold	PG_{HTh}			90		%
PGOOD Hysteresis	PG_{HYS}			10		%
PGOOD Delay	PG_{DLY}			1		ms
PGOOD Sink Capability		$I_{PGOOD} = 10mA$		0.05		V
Power Supply Ripple Rejection	PSRR	$f = 1kHz$, $I_{OUT} = 10mA$		70		dB
		$f = 10kHz$, $I_{OUT} = 10mA$		68		
		$f = 100kHz$, $I_{OUT} = 10mA$		47		
		$f = 1MHz$, $I_{OUT} = 10mA$		55		
Output Noise Voltage	V_{OUTN}	$C_{BP} = 1\mu F$, $V_{OUT} = 3.3V$ $f = 10Hz \sim 100KHz$		115		μV_{RMS}
Thermal Shutdown Temperature	T_{SD}			175		$^\circ C$
Thermal Shutdown Hysteresis	T_{SD_HYS}			35		$^\circ C$

Notes:

- $V_{OUT(S)}$: Output voltage when $V_{IN} = V_{OUT} + 1V$, $I_{OUT} = 1mA$.
- $V_{DROP} = V_{IN1} - (V_{OUT(S)} \times 0.98)$ where V_{IN1} is the input voltage when $V_{OUT} = V_{OUT(S)} \times 0.98$. (The V_{DROP} test with TO263-5L)
- I_{LIM} : Output current when $V_{IN} = V_{OUT(S)} + 1V$ and $V_{OUT} = 0.95 \cdot V_{OUT(S)}$.

TYPICAL PERFORMANCE CHARACTERISTICS

Test Conditions: $V_{IN}=V_{OUT}+1.0V$, $C_{IN} = 4.7\mu F$, $C_{OUT} = 4.7\mu F$, $T_A=25^\circ C$, unless otherwise indicated.

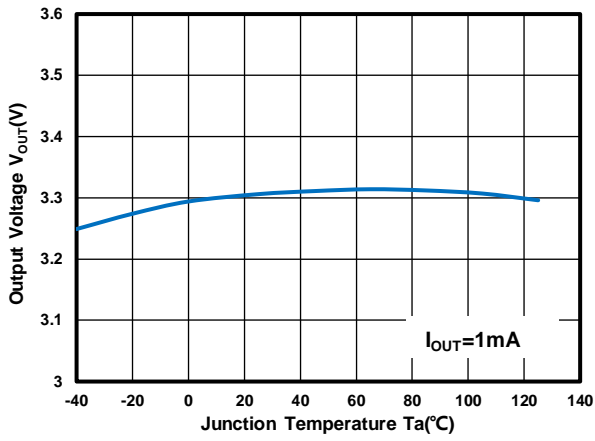

Output Voltage vs. Temperature at $V_{OUT}=3.3V$

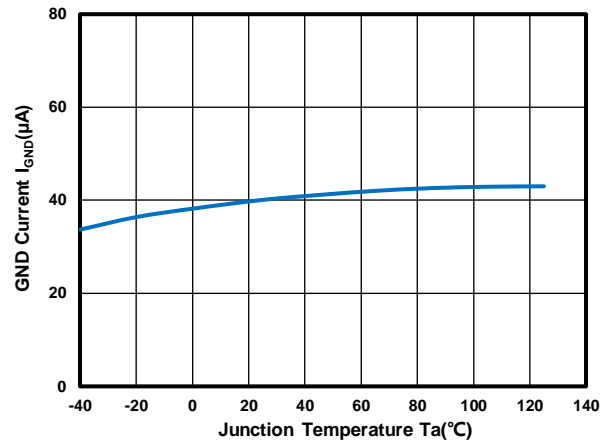

GND Current vs. Temperature at $V_{OUT}=3.3V$

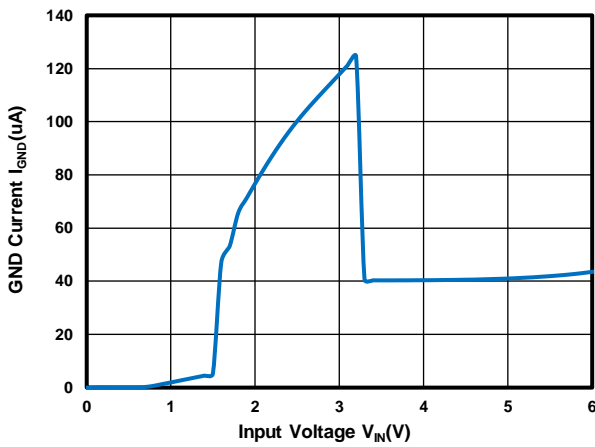

GND Current vs. Input Voltage at $V_{OUT}=3.3V$

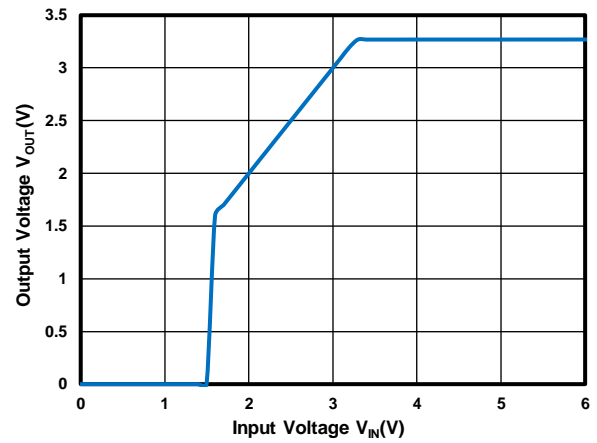

Output Voltage vs Input Voltage at $V_{OUT}=3.3V$

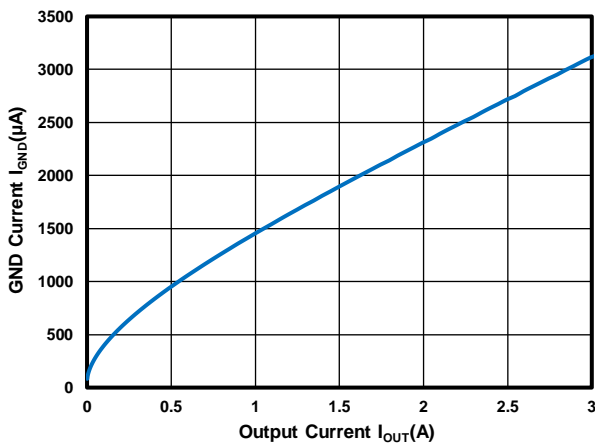

GND Current vs Output Current at $V_{OUT}=3.3V$

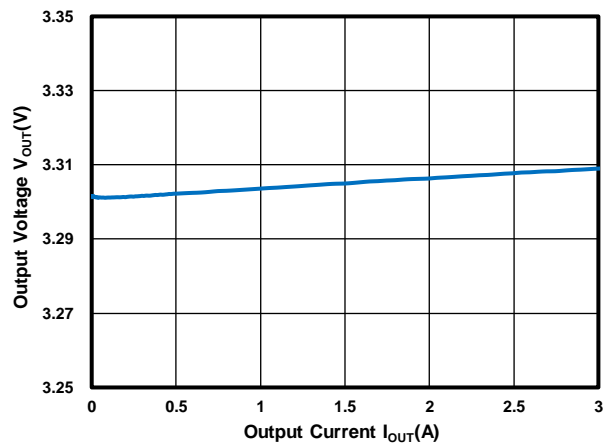

Output Voltage vs Output Current at $V_{OUT}=3.3V$

3A 5V-Adjustable Low Dropout Voltage Regulator

TYPICAL PERFORMANCE CHARACTERISTICS(CONTINUED)

Test Conditions: $V_{IN}=V_{OUT}+1.0V$, $C_{IN}=4.7\mu F$, $C_{OUT}=4.7\mu F$, $T_A=25^\circ C$, unless otherwise indicated.

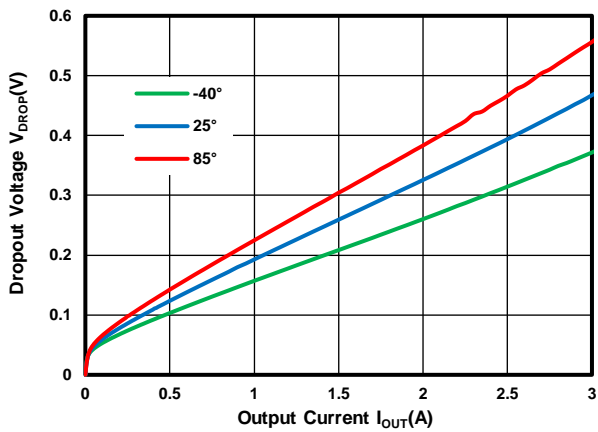

Dropout Voltage vs. Output Current at $V_{OUT}=3.3V$

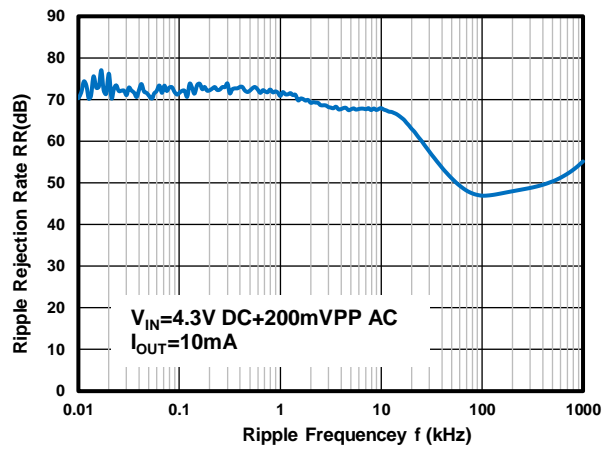

Power Supply Rejection Ratio at $V_{OUT}=3.3V$

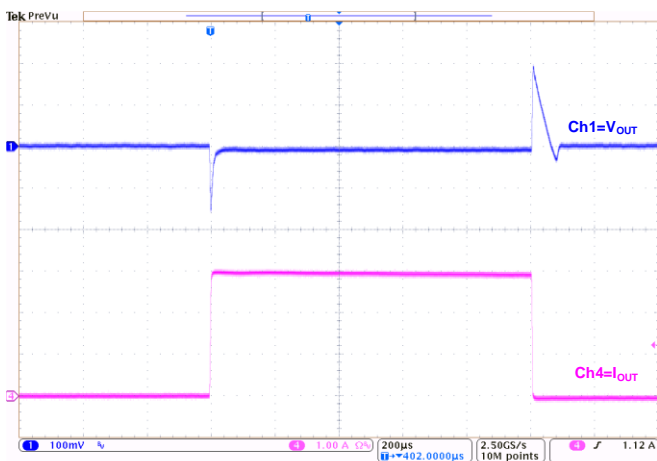

Load Transient at $V_{OUT}=3.3V$
($I_{OUT}=10mA \sim 3A \sim 10mA$)

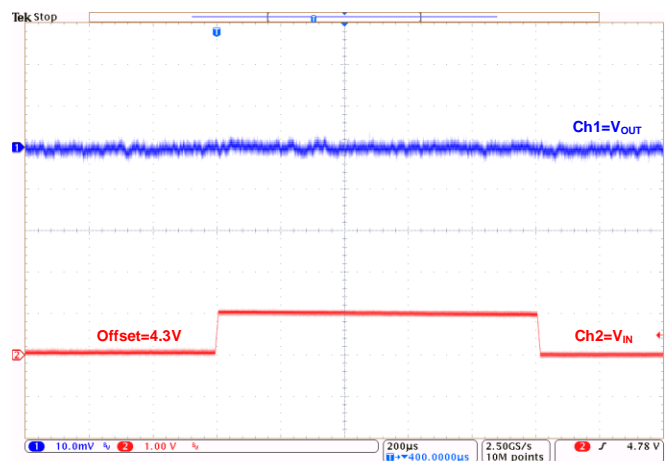

Line Transient at $V_{OUT}=3.3V$
($I_{OUT}=10mA$)

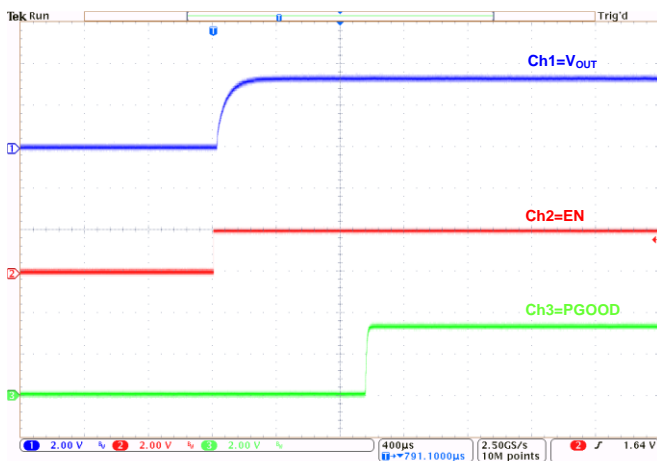

Enable Startup at $V_{OUT}=3.3V$
($I_{OUT}=0mA$)

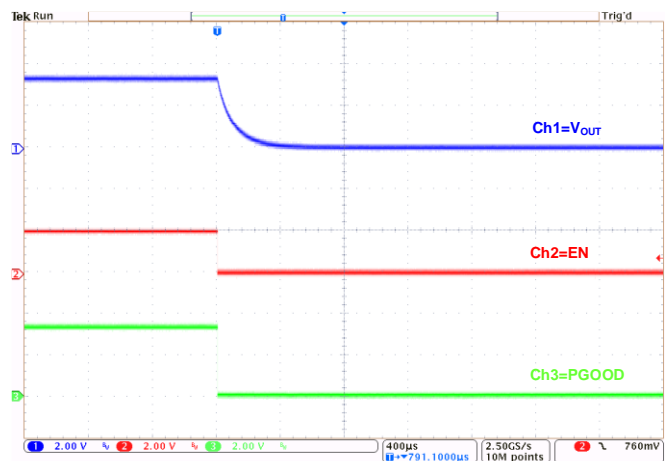

Enable Shutdown at $V_{OUT}=3.3V$
($I_{OUT}=0mA$)

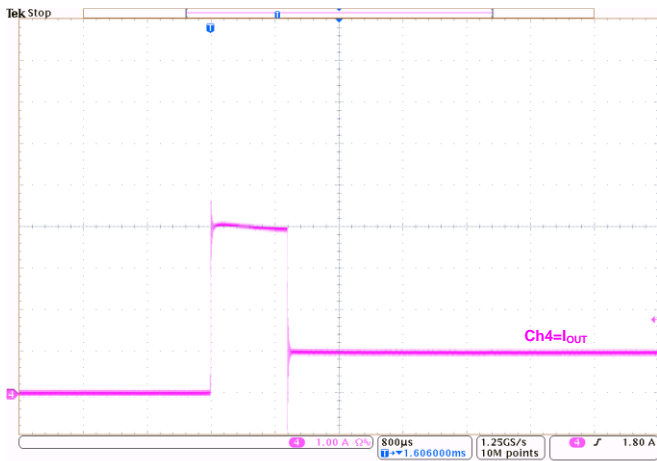
TYPICAL PERFORMANCE CHARACTERISTICS(CONTINUED)Test Conditions: $V_{IN}=V_{OUT}+1.0V$, $C_{IN}=4.7\mu F$, $C_{OUT}=4.7\mu F$, $T_A=25^\circ C$, unless otherwise indicated.Output Current Fold-back at $V_{OUT}=3.3V$

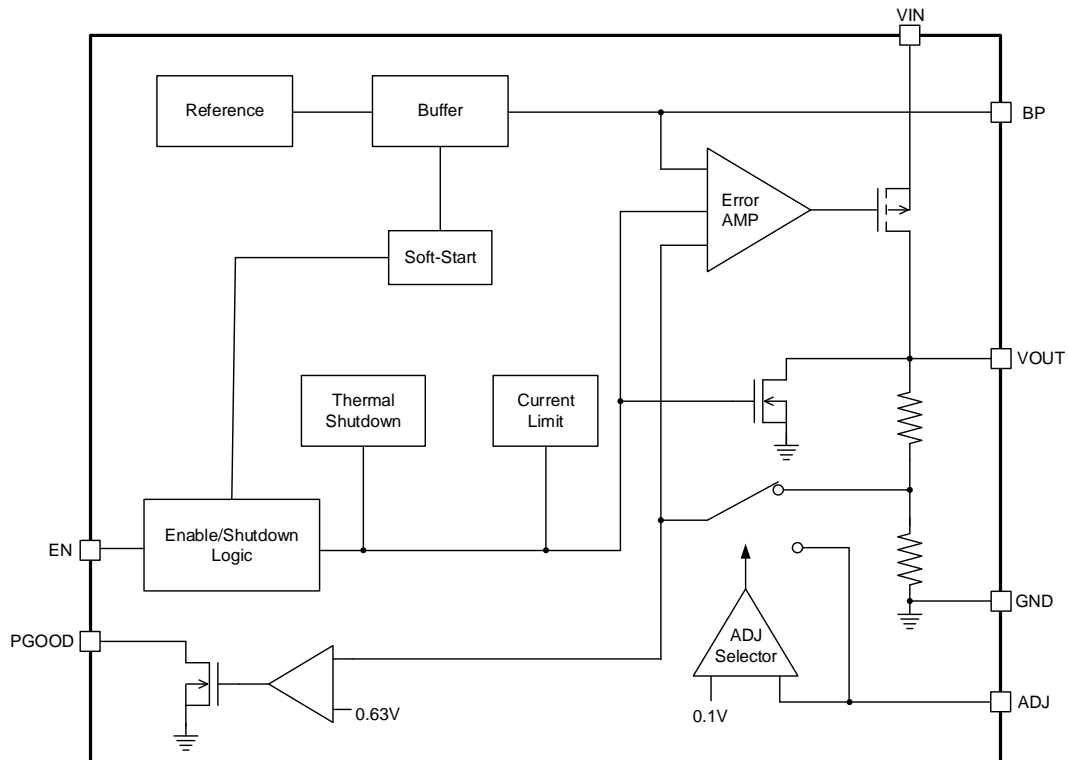
BLOCK DIAGRAM**THEORY OF OPERATION**

The MD7673 is a low-dropout voltage regulator with low quiescent current, low noise and high PSRR. It can support load current up to 3A. It incorporates current-limit and thermal protection features.

SHUTDOWN

By connecting EN pin to GND, the MD7673 can be shutdown to reduce the supply current to 0.01 μA (typ.). In this mode, the output voltage of MD7673 is equal to 0V.

CURRENT LIMIT and SHORT CIRCUIT PROTECTION

The MD7673 includes current limit protection feature, which monitors and controls the maximum output current. If the output is overloaded or shorted to ground, this can protect the device from being damaged. When output is shorted to ground, current limit will be adjusted to about 25% of the rated current limit to protect the device.

THERMAL PROTECTION

The MD7673 includes a thermal protection feature that protects the IC by turning off the pass transistor when the maximum junction temperature T_J exceed 175°C.

POWER DISSIPATION

The power dissipation across the device can be calculated as:

$$P_D = I_{OUT} * (V_{IN} - V_{OUT})$$

The total junction temperature is calculated as:

$$T_J = T_A + (P_D * \theta_{JA})$$

where, T_J is the junction temperature, T_A is the ambient temperature and θ_{JA} is the thermal resistance between junction to ambient. There is a temperature rise associated with this power dissipated while operating in a given ambient temperature. If the calculated junction temperature exceeds maximum junction temperature specification, then the built-in thermal protection feature is triggered as described previously. To insure reliable performance, the maximum allowable power dissipation for a given ambient temperature must be considered and it can be calculated as follows:

$$P_{D(MAX)} = (T_{J(MAX)} - T_A) / \theta_{JA}$$

3A 5V-Adjustable Low Dropout Voltage Regulator

where, $T_{J(MAX)}$ is the maximum junction temperature, T_A is the ambient temperature and θ_{JA} is the thermal resistance between junction to ambient. In order to insure the best thermal flow, proper mounting of the IC is required.

INPUT & OUTPUT CAPACITORS

MD7673 is optimized for use with ceramic capacitors. In order to ensure stability of the device, please place an output ceramic capacitor of 4.7 μ F or bigger at the V_{OUT} pin and GND pin as close as possible. An input capacitor of 4.7 μ F is recommended. X5R or X7R ceramic capacitors are recommended as they have the best temperature and voltage characteristics. If the impedance of the power supply is high, which is caused by forgetting installing input capacitor or installing too small value capacitor, the oscillation may occur.

When large output current switching (>500mA) are required in the application, a greater value of input/output capacitors ($\geq 10 \mu$ F) would be recommended to ensure the device to operate smoothly.

TYPICAL APPLICATION SCHEMATIC

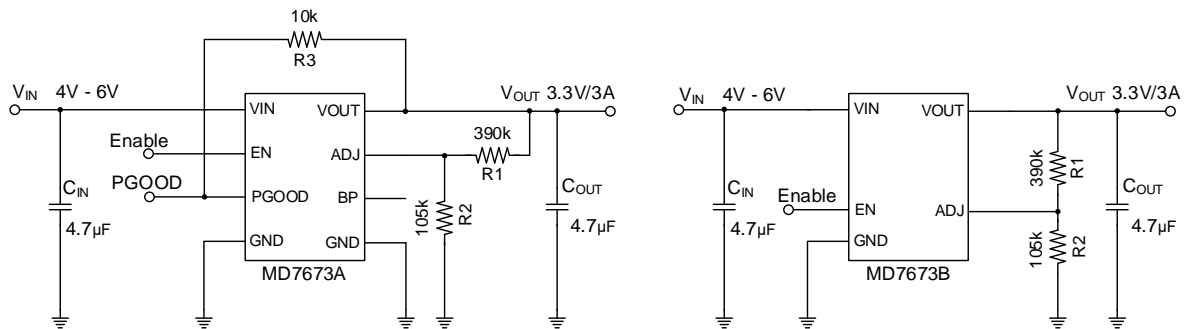

PROGRAMMING THE OUTPUT VOLTAGE

MD7673's internal feedback resistors set the output voltage V_{OUT} to 5V when the ADJ pin is connected to GND. Alternatively; the output voltage is adjustable via the external feedback resistor network R1 and R2 by calculating the following formula:

$$V_{OUT} = V_{REF} * \left(1 + \frac{R1}{R2}\right)$$

where, V_{REF} is the reference voltage set internally at 0.7V nominal.

NOISE BYPASS CAPACITOR (For MD7673A)

A 1 μ F bypass capacitor at BP pin can reduce output voltage noise. This pin can be left floating if it is unnecessary.

POWER-GOOD FUNCTION

The power-good circuit monitors the voltage at the feedback pin to indicate the status of the output voltage. When the output voltage falls below the PGOOD fall threshold voltage (PG_{LTH}), the PGOOD pin open-drain output engages and pulls the PGOOD pin close to GND. When the output voltage exceeds PGOOD rise threshold voltage (PG_{HTH}), the PGOOD pin becomes high impedance. By connecting a pullup resistor to external pullup supply voltage (default for V_{OUT}), any downstream device can receive power-good as a logic signal that can be used for sequencing. Make sure that the external pullup supply voltage results in a valid logic signal for the receiving device. Using a pullup resistor from 10 k Ω to 100 k Ω is recommended.

LAYOUT CONSIDERATION





1. Connect the bottom-side pad to a large ground plane for good thermal conductivity and to reduce the thermal resistance of the device.
2. The input Capacitor C_{IN} and output capacitor C_{OUT} must be placed as close as possible to the pins V_{IN} and V_{OUT} respectively.
3. Use short wires to connect the power supply to pins V_{IN} and GND on the board.

3A 5V-Adjustable Low Dropout Voltage Regulator**Notes on Use**

1. The input capacitor (C_{IN}) and the output capacitor (C_{OUT}) should be placed to the as close as possible with a shorter wiring.
2. If the impedance of the power supply is high, which is caused by forgetting installing input capacitor or installing too small value capacitor, the oscillation may occur.
3. Please pay attention to the operation conditions of input and output voltage and load current, such that the power consumption in the IC should not exceed the allowable power consumption of the package even though the chip has short circuit protection.

IC has a built-in anti-static protection (ESD) circuit, but please do not add excessive stress to the IC.

Ordering Information

Part Name	Package	Marking	Packing quantity	
MD7673A50SF4	ESOP8	 7673A	4000/ Tape & Reel	All packages are lead-free
MD7673B50SF4	ESOP8	 7673B	4000/ Tape & Reel	
MD7673C50SF4	ESOP8	 7673C	4000/ Tape & Reel	
MD7673E50UB2	TO252-4L	 7673	2500/ Tape & Reel	
MD7673E50VC1	TO263-5L	 7673	800/ Tape & Reel	

PACKAGING INFORMATION

ESOP8 PACKAGE OUTLINE DIMENSIONS

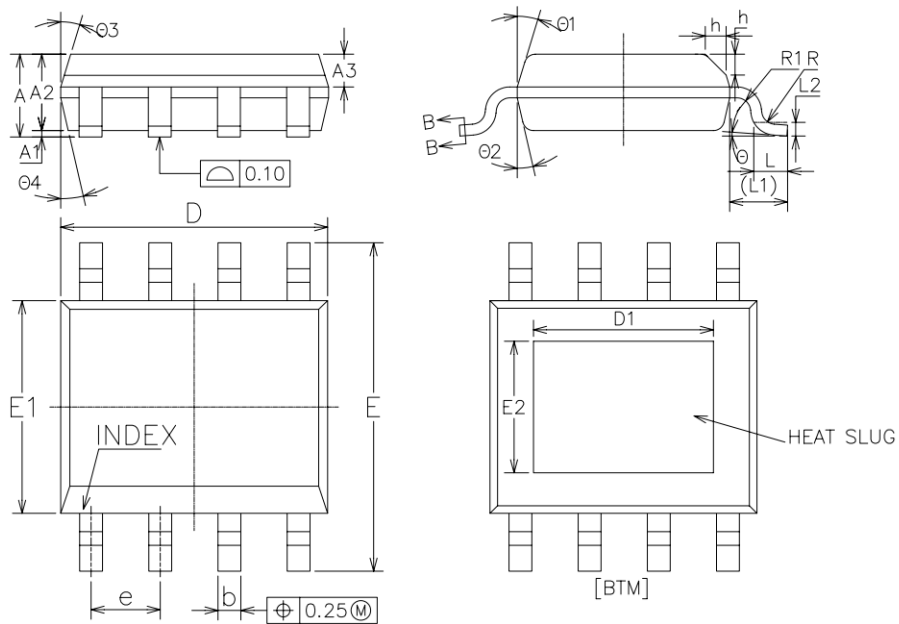

COMMON DIMENSIONS
(UNITS OF MEASURE=MILLIMETER)

SYMBOL	MIN	NOM	MAX	
A	1.35	1.55	1.70	
A1	0	0.10	0.15	
A2	1.25	1.40	1.65	
A3	0.50	0.60	0.70	
b	0.38	—	0.51	
b1	0.37	0.42	0.47	
c	0.17	—	0.25	
c1	0.17	0.20	0.23	
D	4.80	4.90	5.00	
D1	Option 1 Option 2	3.10 2.09	3.30 2.29	3.50 2.49
E	5.80	6.00	6.20	
E1	3.80	3.90	4.00	
E2	Option 1 Option 2	2.20 2.09	2.40 2.29	2.60 2.49
e	1.17	1.27	1.37	
L	0.45	0.60	0.80	
L1	1.04REF			
L2	0.25BSC			
R	0.07	—	—	
R1	0.07	—	—	
h	0.30	0.40	0.50	
theta	0°	—	8°	
theta1	15°	17°	19°	
theta2	11°	13°	15°	
theta3	15°	17°	19°	
theta4	11°	13°	15°	

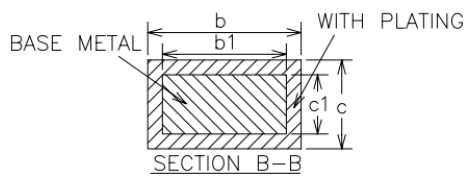

PACKAGING INFORMATION(CONTINUED)

TO252-4L PACKAGE OUTLINE DIMENSIONS

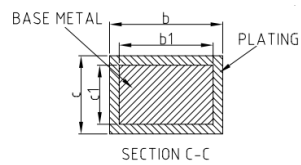
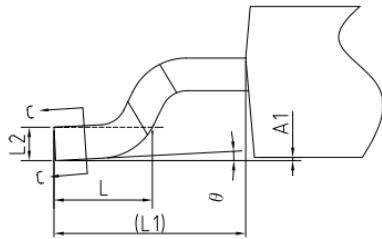
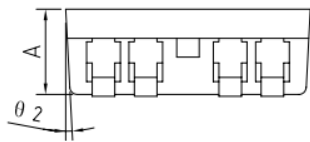
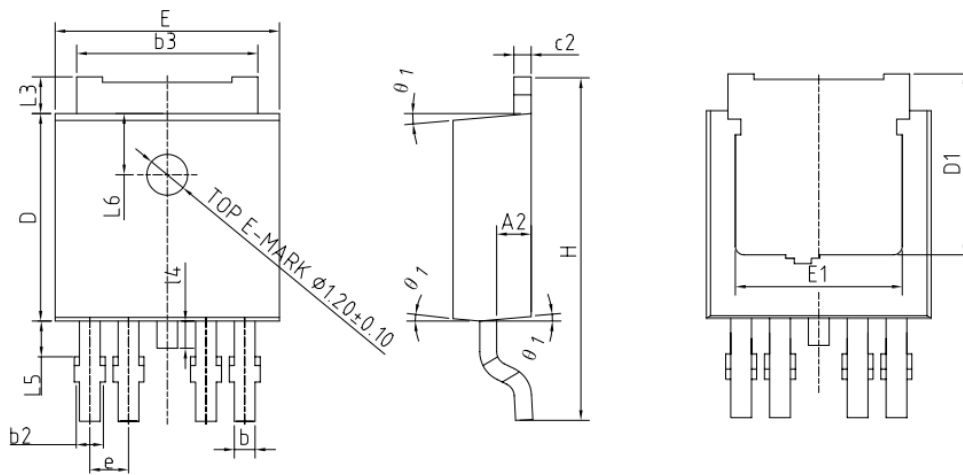

COMMON DIMENSIONS
(UNITS OF MEASURE=MILLIMETER)

SYMBOL	MIN	NOM	MAX
A	2.20	2.30	2.38
A1	0	-	0.10
A2	0.90	1.00	1.10
b	0.57	-	0.70
b1	0.56	0.61	0.66
b2	0.57	-	0.86
b3	5.23	5.33	5.44
c	0.50	-	0.56
c1	0.50	0.51	0.52
c2	0.50	-	0.56
D	6.00	6.10	6.20
D1	5.00	-	-
E	6.50	6.60	6.70
E1	4.70	-	-
e	1.14BSC		
H	9.80	10.10	10.40
L	1.40	1.50	1.70
L1	2.90REF		
L2	0.51BSC		
L3	0.90	-	1.25
L4	0.60	0.80	1.00
L5	0.90	-	1.50
L6	1.80REF		
theta	0°	-	8°
theta 1	3°	5°	7°
theta 2	1°	3°	5°

PACKAGING INFORMATION

TO263-5L PACKAGE OUTLINE DIMENSIONS

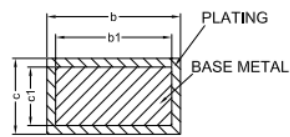
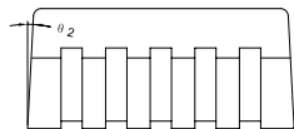
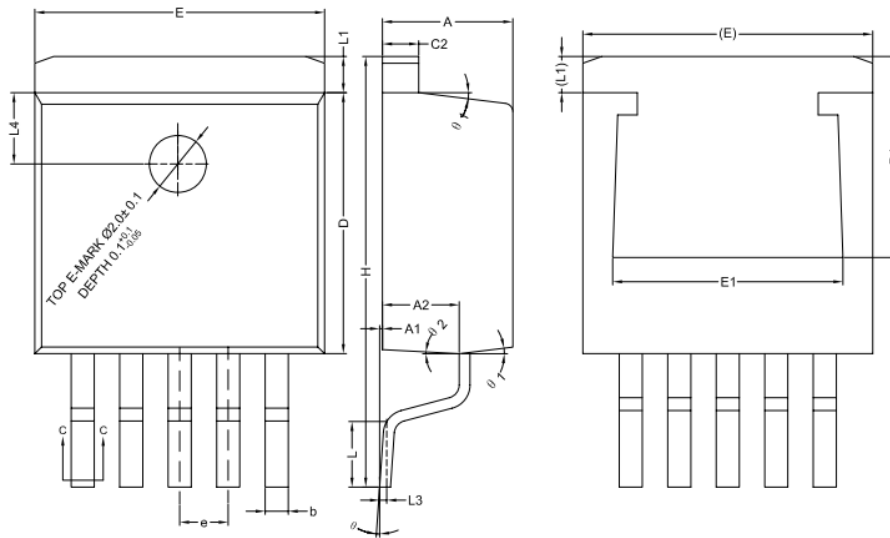

SECTION C-C

COMMON DIMENSIONS
(UNITS OF MEASURE=MILLIMETER)

SYMBOL	MIN	NOM	MAX
A	4.40	4.57	4.70
A1	0	0.10	0.25
A2	2.59	2.69	2.79
b	0.77	-	0.90
b1	0.76	0.81	0.86
c	0.34	-	0.47
c1	0.33	0.38	0.43
c2	1.22	-	1.32
D	9.05	9.15	9.25
D1	6.86	-	7.50
E	10.06	10.16	10.26
E1	7.50	-	8.30
e	-	1.70BSC	-
H	14.70	15.10	15.50
L	2.00	2.30	2.60
L1	1.17	1.27	1.40
L3	-	0.25BSC	-
L4	-	2.00REF	-
theta	0°	-	8°
theta 1	5°	7°	9°
theta 2	1°	3°	5°

For the newest datasheet, please see the website:

www.md-ic.com.cn

Version V1.0: 20201219

X-ON Electronics

Largest Supplier of Electrical and Electronic Components

Click to view similar products for [LDO Voltage Regulators](#) category:

Click to view products by [Mingda](#) manufacturer:

Other Similar products are found below :

[AP7363-SP-13](#) [NCV8664CST33T3G](#) [L79M05TL-E](#) [AP7362-HA-7](#) [PT7M8202B12TA5EX](#) [TCR3DF185,LM\(CT](#) [TLF4949EJ](#)
[NCP4687DH15T1G](#) [NCV8703MX30TCG](#) [LP2951CN](#) [NCV4269CPD50R2G](#) [AP7315-25W5-7](#) [NCV47411PAAJR2G](#) [AP2111H-1.2TRG1](#)
[ZLDO1117QK50TC](#) [AZ1117ID-ADJTRG1](#) [NCV4263-2CPD50R2G](#) [NCP114BMX075TCG](#) [MC33269T-3.5G](#) [TLE4471GXT](#) [AP7315-33SA-](#)
[7](#) [NCV4266-2CST33T3G](#) [NCP715SQ15T2G](#) [NCV8623MN-50R2G](#) [NCV563SQ18T1G](#) [NCV8664CDT33RKG](#) [NCV4299CD250R2G](#)
[NCV8702MX25TCG](#) [TLE7270-2E](#) [NCV562SQ25T1G](#) [AP2213D-3.3TRG1](#) [AP2202K-2.6TRE1](#) [NCV8170BMX300TCG](#)
[NCV8152MX300180TCG](#) [NCP700CMT45TBG](#) [AP7315-33W5-7](#) [NCP154MX180300TAG](#) [AP2113AMTR-G1](#) [NJW4104U2-33A-TE1](#)
[MP2013AGG-5-P](#) [NCV8775CDT50RKG](#) [NJM2878F3-45-TE1](#) [S-19214B00A-V5T2U7](#) [S-19214B50A-V5T2U7](#) [S-19213B50A-V5T2U7](#) [S-](#)
[19214BC0A-E8T1U7*1](#) [S-19213B00A-V5T2U7](#) [S-19213B33A-V5T2U7](#) [S-19213BC0A-V5T2U7](#) [S-1313D18-N4T1U4](#)