



# Monolithic Amplifier

### THE BIG DEAL

- Super Wideband, DC to 16 GHz
- Excellent Flat Gain,  $\pm 0.75$  dB up to 12 GHz
- Low Current, 20 mA
- Good Input & Output Return Loss ( $> 10$  dB)
- Repeatable performance (HBT Process)
- Small Package (2x2mm 6L MCLP)



Generic photo used for illustration purposes only

CASE STYLE: MC1630-1

### +RoHS Compliant

The +Suffix identifies RoHS Compliance. See our website for methodologies and qualifications

### APPLICATIONS

- Instrumentation
- Cable Infrastructure
- 5G

### PRODUCT OVERVIEW

The EHA-163L+ is a low current, wideband gain block that operates up to 16 GHz fabricated using highly reliable HBT process. This Darlington pair amplifier delivers excellent gain flatness, good return loss, low current with acceptable P1dB and OIP3 across a wide bandwidth without the need of external matching network. It has highly repeatable performance from lot to lot and it is enclosed in a 2mm x 2mm 6-lead package.

### KEY FEATURES

Feature	Advantages
Super Wideband: DC to 16 GHz	Generate purpose wideband amplifier is suitable for various applications.
Low Current, 20mA	Low current consumption is ideal for driver amplifier.
Excellent gain flatness, $\pm 0.75$ dB up to 12 GHz	As a desirable characteristic of a wideband amplifier, excellent gain flatness allows amplification of a signal without changing the waveform in time domain.
No external matching component required	EHA-163L+ provides input & output return loss of 10 dB up to 16 GHz without the need for any external matching components.



LOW CURRENT, WIDEBAND, FLAT GAIN

# Monolithic Amplifier

## EHA-163L+

50Ω DC to 16 GHz

### ELECTRICAL SPECIFICATIONS AT 25°C, V<sub>CC</sub> = +5V, R = 50Ω UNLESS NOTED OTHERWISE

Parameter	Condition (MHz)	V <sub>CC</sub> = +5V <sup>1</sup>			V <sub>CC</sub> = +5V <sup>2</sup>	Units
		Min.	Typ.	Max.	Typ.	
Frequency Range <sup>6</sup>		0.01		16	0.01-16	GHz
Gain	10	—	15.7	—	15.3	dB
	5000	—	15.6	—	14.8	
	8000	13.1	15.3	16.0	14.2	
	10000	—	14.9	—	13.5	
	12000	—	14.2	—	13.1	
	16000	—	11.6	—	8.9	
Input Return Loss	10		18		17	dB
	5000		13		18	
	8000		12		15	
	10000		12		15	
	12000		11		15	
	16000		16		12	
Output Return Loss	10		14		14	dB
	5000		13		14	
	8000		13		16	
	10000		14		16	
	12000		13		11	
	16000		15		8	
Reverse Isolation	8000		19		20	dB
Output Power @1dB Compression	10		7.7		6.2	dBm
	5000		6.0		5.2	
	8000		6.5		6.8	
	10000		4.4		3.9	
	12000		2.7		2.1	
	16000		2.0		0.3	
Output IP33	10		21.0		19	dBm
	5000		17.3		17.8	
	8000		15.6		16.2	
	10000		13.2		13.3	
	12000		12.0		11.6	
	16000		11.8		10.7	
Noise Figure	10		5.2		5.2	dB
	5000		5.0		5.0	
	8000		5.2		5.2	
	10000		5.5		5.3	
	12000		5.4		5.3	
	16000		5.2		6.2	
DC Supply (V <sub>CC</sub> )		+4.75	+5	+5.25	+5	V
Device operating current			20.9	24	19.3	mA
Device current variation vs. temperature <sup>4</sup>			59		59	μA/°C
Device current variation vs voltage <sup>5</sup>			0.0178		0.0178	mA/mV
Thermal Resistance, junction-to-ground lead at 85°C stage temp.			349		349	°C/W

1. Measured on Mini-Circuits Characterization test circuit TB-883-163L+. See Characterization Test Circuit (Fig. 1)  
 2. Measured on Mini-Circuits Recommended Application Circuit TB-995+. See Application Test Circuit (Fig. 2)  
 3. Tested at P<sub>out</sub> = -5 dBm / tone.  
 4. (Current at 85°C - Current at -45°C)/130  
 5. (Current at 5.25V - Current at 4.75V)/1000  
 6. Low frequency cut-off determined by external coupling capacitors & RF choke.

### MAXIMUM RATINGS<sup>7</sup>

Parameter	Ratings
Operating Temperature (ground lead)	-40°C to 85°C
Storage Temperature	-65°C to 150°C
Junction Temperature	150°C
Power Dissipation	0.2W
Input Power (CW)	+22 dBm (5 minutes max.) +8 dBm (continuous)
V <sub>CC</sub> (Supply Voltage)	+6V

7. Permanent damage may occur if any of these limits are exceeded. Electrical maximum ratings are not intended for continuous normal operation.





LOW CURRENT, WIDEBAND, FLAT GAIN

# Monolithic Amplifier

## EHA-163L+

50Ω DC to 16 GHz

### SIMPLIFIED SCHEMATIC AND PAD DESCRIPTION

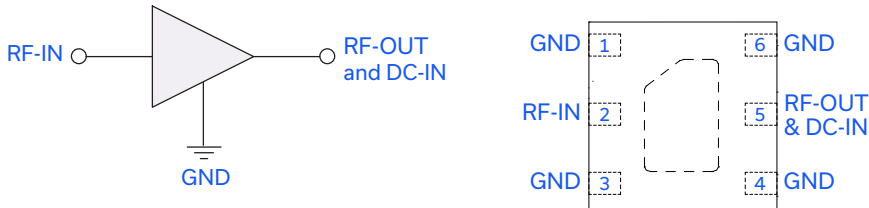

Function	Pad Number	Description
RF-IN	2	RF input
RF-OUT and DC-IN	5	RF output and DC input
GND	Paddle	Ground
NC	1,3,4,6	No connections

### CHARACTERIZATION TEST CIRCUIT

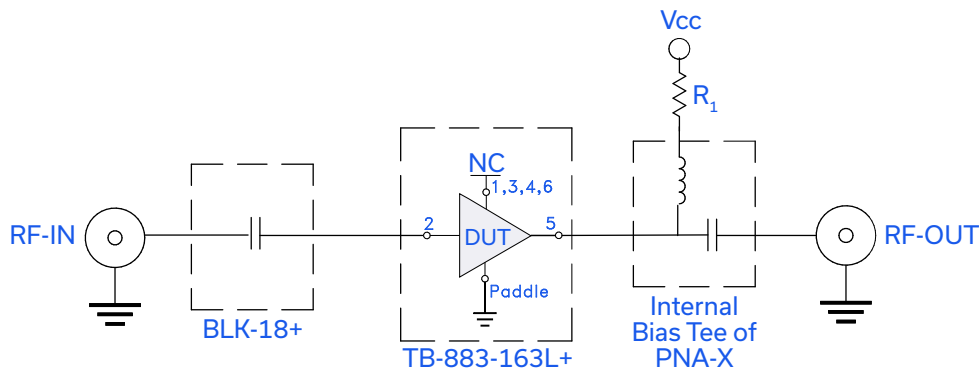

Fig 1. Characterization Circuit

Note: This block diagram is used for characterization. (DUT soldered on Mini-Circuits Characterization test board TB-883-163L+)

Gain, Return loss, Output power at 1dB compression (P1 dB), output IP3 (OIP3) and noise figure measured using Agilent's N5242A PNA-X microwave network analyzer. Rc=49.9 ohms

Conditions:

1. Gain and Return loss: Pin= -25dBm
2. Output IP3 (OIP3): Two tones, spaced 1 MHz apart, -5 dBm/tone at output.





LOW CURRENT, WIDEBAND, FLAT GAIN

# Monolithic Amplifier

## EHA-163L+

50Ω DC to 16 GHz

### APPLICATION TEST CIRCUIT

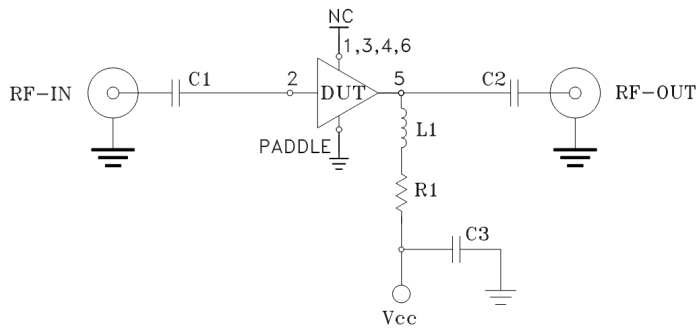

Component	P/N	Supplier	Value	Size
DUT	EHA-163L+	MCL	NA	2mm x 2mm
C1,C2	LBB0402X104MGT1C8	Presidio Components Inc	0.1 $\mu$ F	0402
C3	GRM155R71E103KA01D	Murata	0.01 $\mu$ F	0402
R1	RK73H1JTTD4R99F	KOA	49.9 ohms	0603
L1	BCR-652JLC	Coilcraft	6.5 $\mu$ H	4422

Fig 2. Application Test Circuit

Note: (DUT soldered on Mini-Circuits Application test board TB-995+)

Gain, Return loss, Output power at 1 dB compression (P1 dB), output IP3 (OIP3) and noise figure measured using Agilent's N5242A PNA-X microwave network analyzer.

Conditions:

1. Gain and Return loss: Pin= -25 dBm
2. Output IP3 (OIP3): Two tones, spaced 1 MHz apart, -5 dBm/tone at output.

### PRODUCT MARKING



Marking may contain other features or characters for internal lot control



LOW CURRENT, WIDEBAND, FLAT GAIN

# Monolithic Amplifier

## EHA-163L+

50Ω DC to 16 GHz

ADDITIONAL DETAILED TECHNICAL INFORMATION IS AVAILABLE ON OUR DASH BOARD. TO ACCESS [CLICK HERE](#)

Performance Data	Data Table Swept Graphs S-Parameter (S2P Files) Data Set (.zip file)
Case Style	MC1630-1 Plastic package, exposed paddle, lead finish: Matte-Tin
Tape & Reel Standard quantities available on reel	F66 7" reels with 20, 50, 100, 200, 500, 1K, or 2K devices
Suggested Layout for PCB Design	PL-544
Evaluation Board	TB-995+
Environmental Ratings	ENV08T1

### ESD RATING

Human Body Model (HBM): Class 1A (Pass 250V) in accordance with ANSI/ESD STM 5.1 - 2001

### MSL FLOW CHART

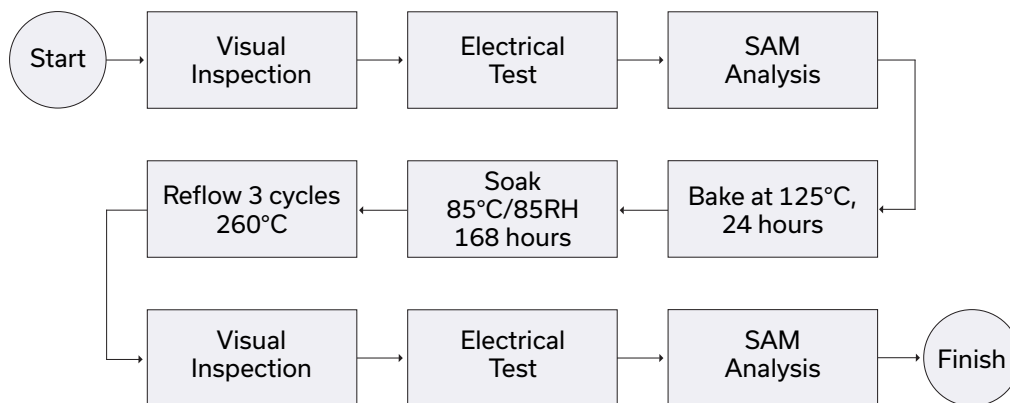

#### NOTES

- A. Performance and quality attributes and conditions not expressly stated in this specification document are intended to be excluded and do not form a part of this specification document.
- B. Electrical specifications and performance data contained in this specification document are based on Mini-Circuit's applicable established test performance criteria and measurement instructions.
- C. The parts covered by this specification document are subject to Mini-Circuits standard limited warranty and terms and conditions (collectively, "Standard Terms"); Purchasers of this part are entitled to the rights and benefits contained therein. For a full statement of the standard terms and the exclusive rights and remedies thereunder, please visit Mini-Circuits' website at [www.minicircuits.com/terms/viewterm.html](http://www.minicircuits.com/terms/viewterm.html)



## X-ON Electronics

Largest Supplier of Electrical and Electronic Components

*Click to view similar products for [RF Amplifier](#) category:*

*Click to view products by [Mini-Circuits](#) manufacturer:*

Other Similar products are found below :

[A1212](#) [AL7](#) [SE2433T-R](#) [SMA3101-TL-E](#) [A66-1](#) [A66-3](#) [A81-2](#) [LX5535LQ](#) [SMA411](#) [SMA531](#) [SST12LP19E-QX6E](#) [WPM0510A](#)  
[MMZ25332B4T1](#) [SMA1212](#) [MAAMSS0041TR](#) [MAAM37000-A1G](#) [SMA88-1](#) [SMA4011](#) [A231](#) [UA5M20MC](#) [XD1001-BD-000V](#)  
[BGU6009/N2X](#) [BGS8H2X](#) [BGS8324Z](#) [SMA66](#) [A12](#) [MMA022AA](#) [MAAP-015024-DIE](#) [AMS-162-PIN](#) [CA70-2](#) [MMG30301BT1](#) [LA17](#)  
[MMA041PP5](#) [MAMF-011119-TR1000](#) [A57](#) [GRF2011](#) [MMA044PP3](#) [ISL55007IEZ-T7](#) [ISL55008IEZ-T7](#) [ISL55009IEZ-T7](#) [ISL55010IEZ-T7](#) [ISL55011IEZ-T7](#) [NSVG3117SG6T1G](#) [BGA7H1BN6E6327](#) [BGA125N6E6327XTSA1](#) [TSS-23LN+](#) [TRF1305B2RYPR](#) [TRF1208RPVT](#)  
[LTC6433AIUF-15#PBF](#) [HMC797APM5ETR-R5](#)