

MMIC SP4T RF Switch

HSWA4-63DR+

Absorptive RF Switch with internal driver
Single Supply Voltage, +2.3V to +5.5V

The Big Deal

- High Isolation, 61 dB @ 0.9 GHz
- Low insertion loss, 0.9 dB at 0.9 GHz
- High IP3, +58 dBm
- Fast switching, 255ns
- Low current consumption, 110µA
- Immune to latch-up

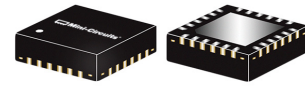

CASE STYLE: DG984-1

Product Overview

Mini-Circuits' HSWA4-63DR+ is a MMIC SP4T absorptive switch with an internal driver designed for wide-band operation from 30 MHz to 6 GHz, supporting many applications requiring high performance across a wide frequency range. This model provides excellent isolation, fast switching speed and high linearity in a tiny 4x4mm 24-Lead MCLP package. Produced using a unique CMOS process on silicon, it offers the performance of GaAs with the advantages of conventional CMOS devices. HSWA4-63DR+ provides a high level of ESD protection, MSL1 moisture sensitivity rating, and excellent repeatability.

Key Features

Feature	Advantages
Wideband, 30 MHz to 6.0 GHz	One model can be used in many applications, saving component count. Also ideal for wideband applications such as military and instrumentation.
Absorptive switch	In the off condition, RF output ports which are not switched ON are terminated into 50Ω. This enables proper impedance termination of the circuitry following the RF output ports, preventing any unintended action such as oscillation.
High Isolation: • 61 dB at 0.9 GHz • 32 dB at 6 GHz	High isolation significantly reduces leakage of power into OFF ports.
High linearity • +58 dBm IIP3 • +97 dBm IIP2 at 1.9 GHz	High linearity minimizes unwanted intermodulation products which are difficult or impossible to filter in multi-carrier environments such as CATV, or in the presence of strong interfering signal from adjacent circuitry or received by antenna.
Built-in negative voltage generator	Operates with single positive supply voltage; no need for DC blocking capacitors, unless external DC is present at the RF ports.
Built-in CMOS driver	No need for external driver, saving PCB space and cost.
Wide Supply Voltage and low current +2.3 to 5.5V and 110µA typ.	Ideal for battery operated systems consuming very low current for long battery life.
Immune to Latch-up	Unlike conventional CMOS devices, HSWA is immune to latch-up
Tiny size, 4 x 4mm QFN package	Tiny footprint saves space in dense layouts while providing low inductance, repeatable transitions, and excellent thermal contact to the PCB.



MMIC SP4T RF Switch

50Ω 30MHz - 6 GHz

Absorptive RF Switch with internal driver
Single Supply Voltage, +2.3V to +5.5V

Product Features

- High Isolation, 61 dB typ. at 0.9 GHz
- Low insertion loss, 0.9 dB typ. at 0.9 GHz
- High IP3, 58 dBm typ.
- Fast switching time, 255 ns typ.
- Low current consumption, 110 μA typ.
- Immune to latch-up

Typical Applications

- Defense
- Test and Measurements
- Switch matrices

General Description

HSWA4-63DR+ is a high isolation absorptive SP4T switch with integral CMOS driver, operates with single positive supply voltage while consuming, 110 μA typical. It has been designed for very wideband operation. It is packaged in a tiny 4 x 4 x 0.9 mm 24-lead package and is rated MSL1.

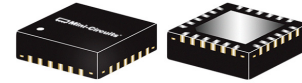

Generic photo used for illustration purposes only
CASE STYLE: DG984-1

HSWA4-63DR+

+RoHS Compliant

The +Suffix identifies RoHS Compliance. See our web site for RoHS Compliance methodologies and qualifications

Simplified Schematic and Pad Description

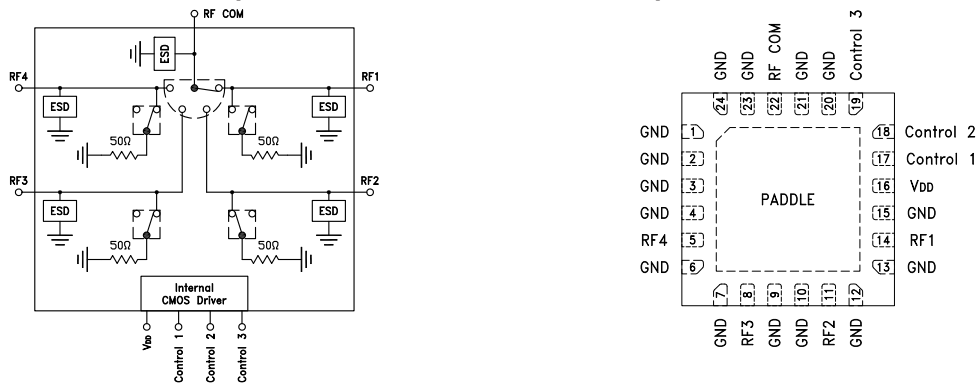

Function	Pad Number	Description
RF COM	22	RF common/ SUM port*
RF1	14	RF OUT #1/Input #1*
RF2	11	RF OUT #2/Input #2*
RF3	8	RF-OUT #3 /Input #3*
RF4	5	RF-OUT #4 /Input #4*
Control 1	17	CMOS Control IN #1
Control 2	18	CMOS Control IN #2
Control 3	19	CMOS Control IN #3
VDD	16	Supply voltage
GND	1-4, 6,9,10,12,13,15 20,21,23,24	RF ground

*Must be held at 0VDC. If required add DC blocking capacitors on these ports.



RF Electrical Specifications¹, 30MHz - 6 GHz, T_{AMB}=25°C, V_{DD}= +3.3V

Parameter	Condition (MHz)	Min.	Typ.	Max.	Units
Frequency range		30		6000	MHz
Insertion loss ²	30 - 900	—	0.9	1.1	dB
	900 - 2100	—	1.1	1.35	
	2100 - 2700	—	1.15	1.4	
	2700 - 4000	—	1.25	1.5	
	4000 - 6000	—	1.9	2.5	
Isolation between Common port and output ports	30 - 900	55	61	—	dB
	900 - 2100	52	55	—	
	2100 - 2700	50	52	—	
	2700 - 4000	42	43	—	
	4000 - 6000	27	32	—	
Isolation among output ports	30 - 900	56	61	—	dB
	900 - 2100	51	54	—	
	2100 - 2700	50	52	—	
	2700 - 4000	41	44	—	
	4000 - 6000	29	32	—	
Return loss (ON STATE)	30 - 4000	—	17	—	dB
	4000 - 6000	—	12	—	
Return loss (OFF STATE)	30 - 4000	—	22	—	dB
	4000 - 6000	—	19	—	
Input IP2	1900		97		dBm
Input IP3	1900	—	58	—	dBm
0.1 dB Input compression ³	900	—	35	—	dBm
RF Input operating power, CW	30 - 6000	—	—	33	dBm
RF input power into terminated output ports, CW	30 - 6000	—	—	24	dBm

DC Electrical Specifications

Parameter	Min.	Typ.	Max.	Units
Supply voltage, V _{DD}	2.3		5.5	V
Supply current		110		μA
Control voltage Low	-0.3		0.6	V
Control voltage High	1.17		3.6	V
Control current			1	μA

Notes:

1. Tested on Mini-Circuits' test board TB-927+, using Agilent's N5230A network analyzer (see Characterization test circuit, Fig.1).
2. Insertion loss values are de-embedded from test board loss.
3. Do not exceed RF input power as shown in Absolute Maximum Ratings table.

Switching Specifications

Parameter	Condition	Min.	Typ.	Max.	Units
Switching time 50% control to 90/10% RF	f _{FR} =50 MHz f _{ctrl} =50 KHz V _{ctrl} High=3.3V V _{ctrl} Low=0V		255	330	nS
Video feed-through			14		mV _{p-p}
Rise/Fall time 10% to 90% or 90% to 10%			100		nS

Absolute Maximum Ratings⁴

Parameter	Ratings
Operating temperature	-40°C to +105°C
Storage temperature	-65°C to 150°C
V _{DD} , Supply voltage	-0.3 to 5.5V
Voltage control	-0.3V Min. 3.6 Max.
RF Input power, CW	34 dBm

4. Operation of this device above any of these conditions may cause permanent damage.

Truth Table- 3 Pin Control

Mode	State of Control Voltage		
	Control 3	Control 2	Control 1
RF COM-RF1 ON	Low	Low	High
RF COM-RF2 ON	Low	High	Low
RF COM-RF3 ON	Low	High	High
RF COM-RF4 ON	High	Low	Low
	Low	Low	Low
All off	High	Low	High
All off	High	High	Low
Unsupported	High	High	High

Truth Table- 2 Pin Control⁶

Mode	State of Control Voltage	
	Control 2	Control 1
RF COM-RF1 ON	Low	High
RF COM-RF2 ON	High	Low
RF COM-RF3 ON	High	High
RF COM-RF4 ON	Low	Low

6. Pad 19= control 3 must be grounded.

Characterization Test Application Circuit

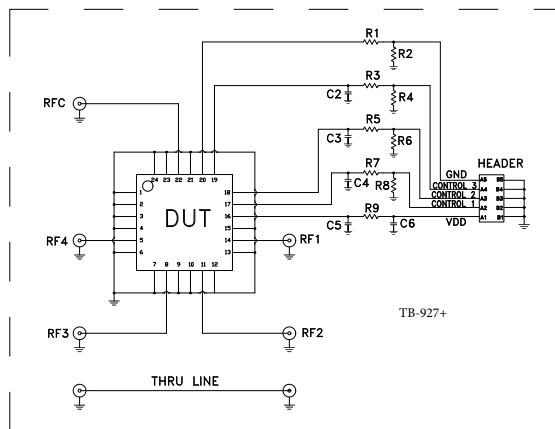

Component	Value	Size
DUT	HSWA4-63DR+	4x4 mm
C2, C3, C4, C5	100pF	0402
C6	1uF	
R1, R2, R3, R5, R7, R9	0 Ohm	
R4, R6, R8	1 MOhm	

Figure 1. Block Diagram of test Circuit used for characterization (DUT soldered on Mini-Circuit's TB-927+)

Parameter	Conditions V _{DD} =+2.3V and 5.5V Control= 0V and 3.3V	Test Equipment
Insertion loss, Isolation, Return loss and DC current	Pin=0 dBm	Keysight N5242A Network Analyzer, E3631A power supply. Cblock: Internal to network Analyzer.
Switching time and DC Current	RF frequency: 50 MHz at 0 dBm, Control frequency: 50 KHz	Keysight 54832B oscilloscope, 81110A pulse generator and E3631A power supply
Input IP3	+15 dBm / tone	Keysight ES257D signal generators, E4416A power meter, N9020A Signal analyzer and E3631A power supply
Compression	—	Keysight N5242A Network Analyzer, E3631A power supply

Product Marking

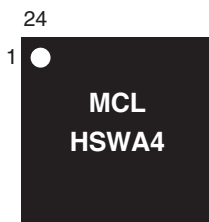

Additional Detailed Technical Information

additional information is available on our dash board. To access this information [click here](#)

Performance Data	Data Table
	Swept Graphs
Case Style	DG984-1 <i>Plastic package: exposed paddle</i> <i>Termination finish: NiPdAu</i>
Tape & Reel Standard quantities available on reel	F68 <i>7" reels with 20, 50, 100, 200, 500 and 3000 devices</i>
Suggested Layout for PCB Design	PL-514
Evaluation Board	TB-927+
Environmental Ratings	ENV84

ESD Rating

Human Body Model (HBM): Class 2 (Pass 2000V) in accordance with MIL-STD-883, Method 3015

Charge Device Model (CDM): Class C1 (Pass 250V) in accordance with JESD22-C101

MSL Rating

Moisture Sensitivity: MSL1 in accordance with IPC/JEDEC J-STD-020D

Additional Notes

- Performance and quality attributes and conditions not expressly stated in this specification document are intended to be excluded and do not form a part of this specification document.
- Electrical specifications and performance data contained in this specification document are based on Mini-Circuit's applicable established test performance criteria and measurement instructions.
- The parts covered by this specification document are subject to Mini-Circuits standard limited warranty and terms and conditions (collectively, "Standard Terms"); Purchasers of this part are entitled to the rights and benefits contained therein. For a full statement of the Standard Terms and the exclusive rights and remedies thereunder, please visit Mini-Circuits' website at www.minicircuits.com/MCLStore/terms.jsp

X-ON Electronics

Largest Supplier of Electrical and Electronic Components

Click to view similar products for [RF Switch ICs](#) category:

Click to view products by [Mini-Circuits](#) manufacturer:

Other Similar products are found below :

[MASW-004100-11930W](#) [MASW-008853-TR3000](#) [BGS13SN8E6327XTSA1](#) [BGSX210MA18E6327XTSA1](#) [SKY13446-374LF](#) [SW-227-PIN](#)
[CG2185X2](#) [CG2415M6](#) [MA4AGSW5](#) [MA4SW410](#) [MA4SW410B-1](#) [MASW-002102-13580G](#) [MASW-008955-TR3000](#) [TGS4307](#)
[BGS1414MN20E6327XTSA1](#) [BGS1515MN20E6327XTSA1](#) [BGSA11GN10E6327XTSA1](#) [BGSX28MA18E6327XTSA1](#) [HMC199AMS8](#)
[HMC986A](#) [SKY13374-397LF](#) [SKY13453-385LF](#) [CG2415M6-C2](#) [HMC986A-SX](#) [SW-314-PIN](#) [UPG2162T5N-E2-A](#) [SKY13416-485LF](#)
[MASWSS0204TR-3000](#) [MASWSS0201TR](#) [MASW-007588-TR3000](#) [MASW-004103-13655P](#) [MASW-003102-13590G](#) [MASWSS0202TR-](#)
[3000](#) [MA4SW310B-1](#) [MA4SW310](#) [MA4AGSW4](#) [MA4SW210](#) [MA4SW110](#) [SW-313-PIN](#) [SKY13321-360LF](#) [SKY13405-490LF](#) [BGSF](#)
[18DM20 E6327](#) [SKY13415-485LF](#) [MMS008PP3](#) [BGS13PN10E6327XTSA1](#) [SKY13319-374LF](#) [BGS14PN10E6327XTSA1](#) [SKY12213-](#)
[478LF](#) [SKY13404-466LF](#) [MASW-011060-TR0500](#)