



CERAMIC

Low Pass Filter

LFCV-1552+

50Ω DC to 15500 MHz

THE BIG DEAL

- Low loss, 0.9 dB typical
- Return loss, 15 dB typical
- Stop Band Rejection 36 dB typical
- Small size 1210 (0.126" x 0.098" x 0.037")

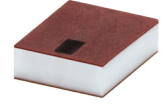

Generic photo used for illustration purposes only

CASE STYLE: JV1210C-7

+RoHS Compliant

The +Suffix identifies RoHS Compliance. See our web site for RoHS Compliance methodologies and qualifications

APPLICATIONS

- 5G MIMO and Back Haul Radio Systems
- Test and Measurement Equipment
- Radar, EW, and ECM Defense Systems

PRODUCT OVERVIEW

Mini-Circuits' LFCV-1552+ is an LTCC low pass filter with a passband from DC to 15500 MHz, supporting a variety of applications. This model provides 0.9 dB typical passband insertion loss and provides a very good stopband rejection due to strategically constructed layout with minimal interaction between components. It handles up to 6.5W RF input power and provides a wide operating temperature range from -55 to +125°C. Housed in a small 1210 ceramic form factor, the filter is ideal for dense PCB layouts and with minimal performance variation due to parasitics.

KEY FEATURES

Feature	Advantages
Ultra-wide stopband	The LTCC lowpass filter provides a very good stopband rejection until 40 GHz suitable for high end applications.
LTCC Construction	Provides repeatable performance in a rugged, ceramic package well suited for tough environments such as high humidity and temperature extremes.
Small size (0.126" x 0.098" x 0.037")	Saves space in dense circuit board layouts and minimizes the effects of parasitics.
Good power handling, 6.5W	Supports a wide range of system power requirements.

REV. A
ECO-015160
LFCV-1552+
EDU4123
URJ
220924





CERAMIC

Low Pass Filter

LFCV-1552+

ELECTRICAL SPECIFICATIONS^{1,2} AT 25°C

Parameter	F#	Frequency (MHz)	Min.	Typ.	Max.	Units	
Passband	Insertion Loss	DC-F1	DC - 15500	—	0.9	1.9	dB
	Freq. Cut-Off	F2*	16900	—	3	—	dB
	Return Loss	DC-F1	DC - 15500	—	15	—	dB
Stop Band	Rejection Loss	F3-F4	21200 - 23000	20	36	—	dB
		F4-F5	23000 - 26500	25	33	—	
		F5-F6	26500 - 40000	—	30	—	

1 DC de-coupling capacitors are required in Applications where DC voltage and/or current is present at either input or output ports. Please contact Mini-Circuits for alternatives if DC pass from IN-OUT is required.

2 Measured on Mini-Circuits Characterization Test Board TB-LFCV-1552+

* Typically, a ±5% frequency deviation from the stated value may occur on a unit-to-unit basis.

MAXIMUM RATINGS

Parameter	Ratings
Operating temperature	-55°C to 125°C
Storage temperature	-55°C to 125°C
RF Power Input*	6.5 W @25°C

*Passband rating, derate linearly to 1.4W at 125°C ambient
Permanent damage may occur if any of these limits are exceeded.

TYPICAL FREQUENCY RESPONSE

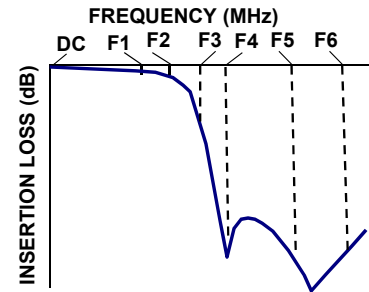

FUNCTIONAL SCHEMATIC

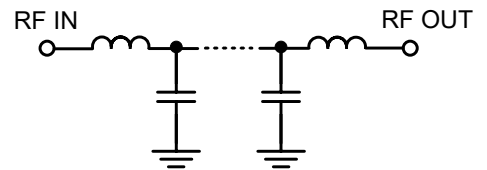



PAD CONNECTIONS

INPUT	1
OUTPUT	2
GROUND	3

PRODUCT MARKING: UH

DEMO BOARD MCL P/N: TB-LFCV-1552+
SUGGESTED PCB LAYOUT (PL-679)

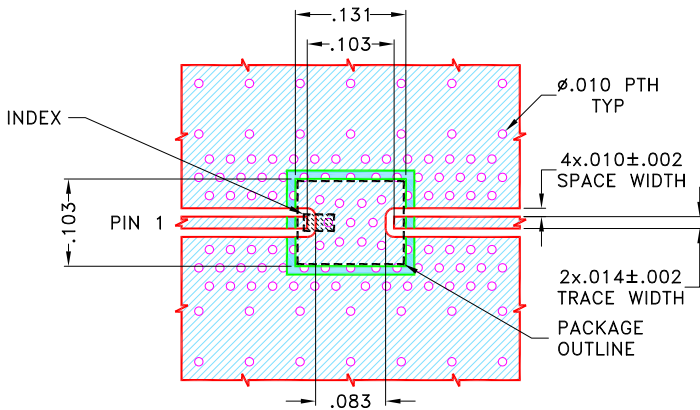

NOTES:

1. COPLANAR WAVEGUIDE PARAMETERS ARE SHOWN FOR ROGERS (R04835 Lo Pro) WITH DIELECTRIC THICKNESS .0073±.0007. COPPER: 1/2 Oz. EACH SIDE.
FOR OTHER MATERIALS TRACE WIDTH AND GAP MAY NEED TO BE MODIFIED.
 2. BOTTOM SIDE OF THE PCB IS CONTINUOUS GROUND PLANE.
- DENOTES PCB COPPER PATTERN WITH SMOBC (SOLDER MASK OVER BARE COPPER)
 DENOTES PCB COPPER PATTERN FREE OF SOLDERMASK

OUTLINE DRAWING

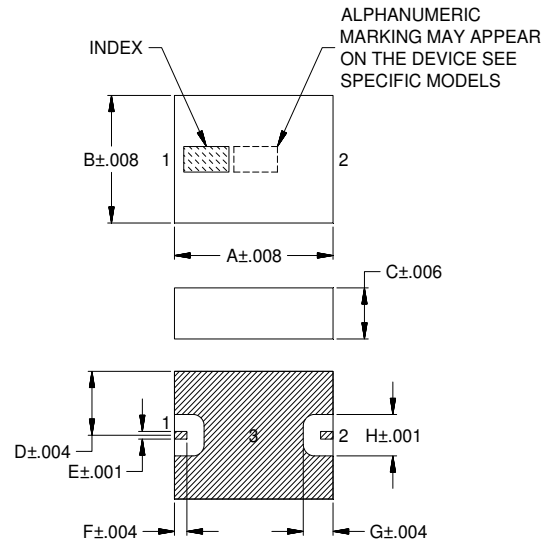

OUTLINE DIMENSIONS (Inches/mm)

A	B	C	D	E
.126	.098	.037	.049	.006
3.20	2.50	0.95	1.25	0.15
F	G	H	Wt.	
.010	.024	.032	grams	
0.25	0.60	0.81	0.03	

Note: Please refer to case style drawing for details



CERAMIC

Low Pass Filter

LFCV-1552+

TYPICAL PERFORMANCE DATA AT 25°C

Frequency (MHz)	Insertion Loss (dB)	Return Loss (dB)
10	0.07	38.27
100	0.08	45.73
2000	0.24	23.71
5000	0.33	19.01
10000	0.44	21.86
15500	0.95	17.85
16900	2.24	8.60
17200	3.14	6.48
19400	20.30	0.81
20250	30.36	0.73
21200	47.16	0.68
23000	40.26	1.15
26500	40.49	2.92
32000	49.66	0.73
40000	30.66	1.45

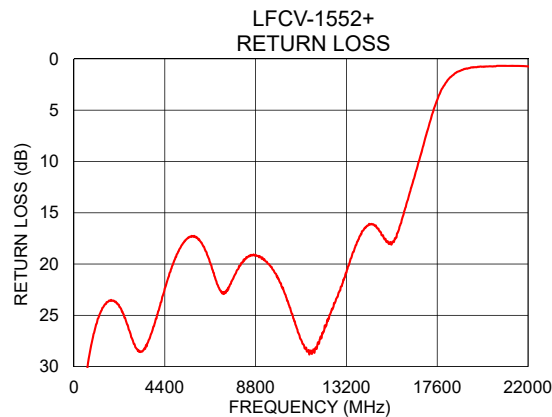
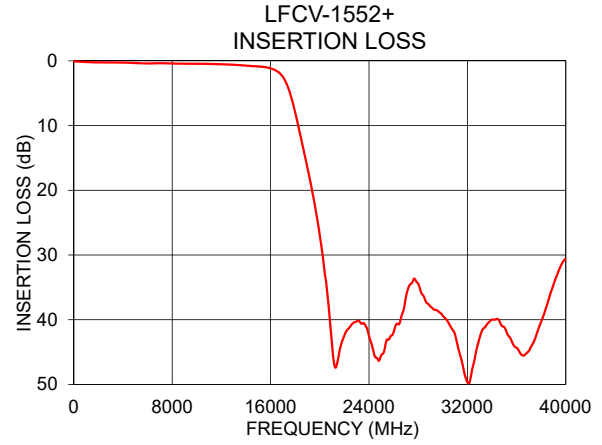
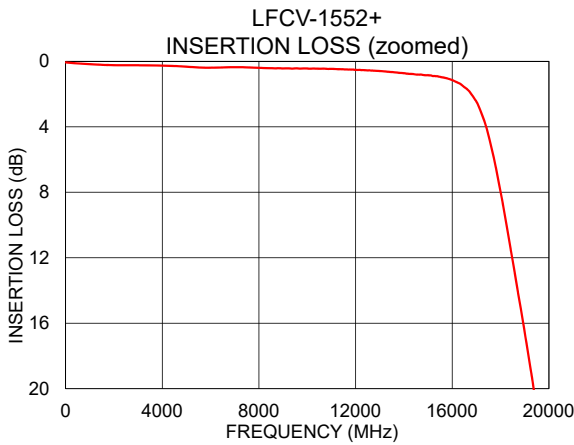

- NOTES**
- A. Performance and quality attributes and conditions not expressly stated in this specification document are intended to be excluded and do not form a part of this specification document.
 - B. Electrical specifications and performance data contained in this specification document are based on Mini-Circuit's applicable established test performance criteria and measurement instructions.
 - C. The parts covered by this specification document are subject to Mini-Circuits standard limited warranty and terms and conditions (collectively, "Standard Terms"); Purchasers of this part are entitled to the rights and benefits contained therein. For a full statement of the standard. Terms and the exclusive rights and remedies thereunder, please visit Mini-Circuits' website at www.minicircuits.com/MCLStore/terms.jsp



X-ON Electronics

Largest Supplier of Electrical and Electronic Components

Click to view similar products for [Signal Conditioning](#) category:

Click to view products by [Mini-Circuits](#) manufacturer:

Other Similar products are found below :

[PD0409J5050S2HF](#) [HHS-109-PIN](#) [AFS14A35-1591.50-T3](#) [JP510S](#) [LFB322G45SN1A504](#) [SF2159E](#) [FM-104-PIN](#) [CER0813B](#)
[MAPDCC0005](#) [3A325](#) [BD0810N50100AHF](#) [DC0710J5005AHF](#) [DC2327J5005AHF](#) [LFL15869MTC1B787](#) [X3C19F1-20S](#)
[CDBLB455KCAX39-B0](#) [RF1353C](#) [051157-0000](#) [PD0922J5050D2HF](#) [600S150FTRB](#) [1E1305-3](#) [1F1304-3S](#) [TP-103-PIN](#)
[BD1222J50200AHF](#) [BD1722J50100AHF](#) [2450DP39K5400E](#) [BD0810J50150AHF](#) [BD1722J50200AHF](#) [DS-327-PIN](#) [MACP-008125-](#)
[CK07F0](#) [DS-329-PIN](#) [DS-313-PIN](#) [TP-104-PIN](#) [TP-101-PIN](#) [HH-128-PIN](#) [8594810000](#) [T-1000-N](#) [JP506S](#) [XC0900P-10S](#) [XC0900B-30S](#)
[CHE1260-QAG](#) [11305-10](#) [5962-9091202MXA](#) [3A412S](#) [X3C06A4-03S](#) [B39000Z3410A4](#) [DSS-333-PIN](#) [PD2425J5050S2HF](#)
[B39242B4360P810](#) [B39781B8005P810](#)