

Ultra High Dynamic Range Monolithic Amplifier

LHA-13LN+

50Ω 1MHz to 1 GHz

The Big Deal

- Ultra-High IP3, +38.3 dBm typ.
- Low supply voltage, 3 to 5V
- Excellent Noise Figure, 1.1 dB typ.



CASE STYLE: DQ1225

Product Overview

LHA-13LN+ (RoHS compliant) is an advanced wideband amplifier fabricated using E-PHEMT technology and offers extremely high dynamic range over a broad frequency range and with low noise figure. In addition, the LHA-13LN+ has good input and output return loss over a broad frequency range. LHA-13LN+ is enclosed in a 3mm x 3mm, 12-lead MCLP package and has very good thermal performance.

Key Features

Feature	Advantages
Broad Band: 1MHz to 1GHz	Broadband covering primary wireless communications bands: VHF, UHF, Cellular
Extremely High IP3 36.1 dBm typical at 1 MHz 38.3 dBm typical at 0.5 GHz	The LHA-13LN+ matches industry leading IP3 performance relative to device size and power consumption. The combination of the design and E-PHEMT Structure provides enhanced linearity over a broad frequency range as evidence in the IP3 being approximately 13-17 dB above the P1dB point. This feature makes this amplifier ideal for use in: <ul style="list-style-type: none">• Driver amplifiers for complex waveform up converter paths• Drivers in linearized transmit systems• Secondary amplifiers in ultra-High Dynamic range receivers
Low Noise Figure, 0.9 dB at 0.5 GHz	Enables lower system noise figure performance and along with High OIP3 provides high dynamic range
Low Supply Voltage	LHA-13LN+ supports low supply voltage operations which indicate low power consumption



Ultra High Dynamic Range Monolithic Amplifier

1 MHz to 1 GHz

Product Features

- High IP3, 38.3 dBm typ. at 0.5 GHz
- Gain, 22.4 dB typ. at 0.5 GHz
- Low noise figure, 1.1 dB at 0.5 GHz
- Low voltage, 5V & 3V



Generic photo used for illustration purposes only

LHA-13LN+

CASE STYLE: DQ1225

Typical Applications

- Base station infrastructure
- CATV
- Cellular

+RoHS Compliant

The +Suffix identifies RoHS Compliance. See our web site for RoHS Compliance methodologies and qualifications

General Description

LHA-13LN+ (RoHS compliant) is an advanced wideband amplifier fabricated using E-PHEMT technology and offers extremely high dynamic range over a broad frequency range and with low noise figure. In addition, the LHA-13LN+ has good input and output return loss over a broad frequency range. LHA-13LN+ is enclosed in a 3mm x 3mm, 12-lead MCLP package and has very good thermal performance.

simplified schematic and pad description

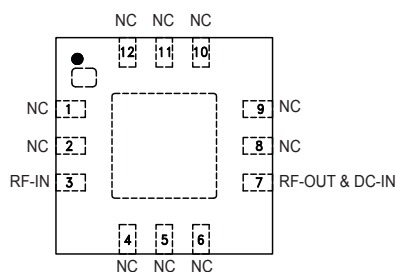
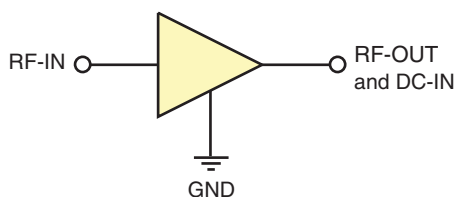

Function	Pin Number	Description
RF IN	3	RF Input
RF-OUT and DC-IN	7	RF Output and DC Bias
GND	Paddle	Connections to ground.
NC	1-2, 4-6, 8-12	No connection, grounded externally

Electrical Specifications¹ at 25°C, 50Ω, unless noted

Parameter	Condition (MHz)	Vd=5V ¹			Vd=3V ¹	Units
		Min.	Typ.	Max.	Typ.	
Frequency Range		1		1000	1-1000	MHz
Gain	1	22.1	24.6	27.1	23.7	dB
	20	—	24.0	—	23.2	
	250	—	22.8	—	22.0	
	500	20.2	22.4	24.6	21.5	
	1000	—	20.1	—	18.7	
Input Return Loss	1		11		10	dB
	20		15		15	
	250		18		18	
	500		18		15	
	1000		11		9	
Output Return Loss	1		12		12	dB
	20		20		22	
	250		18		20	
	500		25		22	
	1000		11		9	
Reverse isolation	500		26		25.6	dB
Output Power @ 1 dB compression	1		20.8		14.6	dBm
	20		22.0		15.8	
	250		24.2		19.3	
	500		23.9		18.9	
	1000		23.3		17.6	
Output IP3 ²	1	—	36.1		29.6	dBm
	20	—	38.9		32.5	
	250	—	40.0		33.6	
	500	36	38.3		32.3	
	1000	—	36.4		28.5	
Noise Figure	1		3.1		3.0	dB
	20		1.1		1.0	
	250		0.9		1.0	
	500		1.1		1.0	
	1000		1.2		1.2	
Device Operating Voltage			5.0		3.0	V
Device Operating Current			143	162	73	mA
Device Current Variation vs. Temperature ³			98.2		-29.7	μA/°C
Device Current Variation vs Voltage			0.0355		0.0354	mA/mV
Thermal Resistance, junction-to-ground lead Junction-to-ground lead at 85°C stage temperature			23.3		23.3	°C/W

1. Measured on Mini-Circuits Characterization test board TB-1063-13LN+. See Characterization Test Circuit (Fig. 1)
 2. Tested at Pout= 0 dBm / 1tone.
 3. (Current at 105°C — Current at -45°C)/140

Absolute Maximum Ratings⁴

Parameter	Ratings
Operating Temperature (ground lead)	-40°C to 105°C
Storage Temperature	-65°C to 150°C
Power Dissipation	3.3 W ⁵
Input Power (CW)	+21 dBm (5 minutes max) ⁶ +6 dBm (continuous) for 1-10 MHz +8 dBm (continuous) for 10-1000 MHz
DC Voltage on Pad 7	10V

4. Permanent damage may occur if any of these limits are exceeded.
 Electrical maximum ratings are not intended for continuous normal operation.
 5. up to 85°C, derate linearly to 2.5 W at 95°C.
 6. up to 85°C, derate linearly to 18 dBm at 95°C.

Characterization Test / Recommended Application Circuit

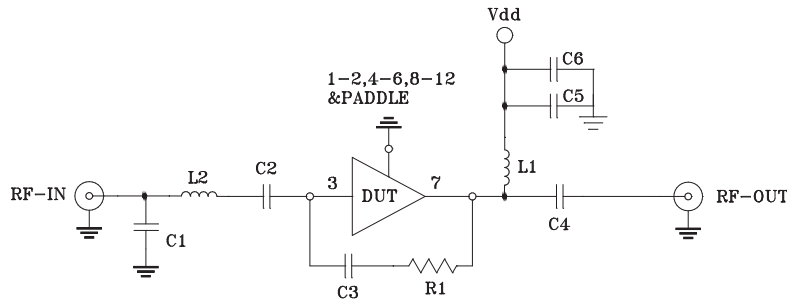

Components	Size	Value	Manufacturer	P/N
C1	0402	1.5 pF	Murata	GRM1555C1H1R5CA01
C2	0603	2.2 uF		GRM188R61C225KE15
C3	0402	0.1 uF		GRM155R71C104KA88
C4	0603	2.2uF		GRM188R61C225KE15
C5	0402	1000 pF		GRM1555C1H102JA01
C6	0805	10 uF		GRM21BR61C106KE15
L1	1210	15 uH		LQH32DN150K53L
L2	0603	5.1 nH	Coilcraft	0603CS-5N1XJL
R1	0402	1500 Ohms	Koa	RK73H1ELTP1501F

Fig 1. Block Diagram of Test Circuit used for characterization. (DUT soldered on Mini-Circuits Characterization test board TB-1063-13HLN+) Gain, Return loss, Output power at 1dB compression (P1 dB), output IP3 (OIP3) and noise figure measured using Agilent’s N5242A PNA-X microwave network analyzer.

Conditions:

1. Gain and Return loss: Pin= -25dBm
2. Output IP3 (OIP3): Two tones, spaced 1 MHz apart, 0 dBm/ tone at output.

Product Marking



Marking may contain other features or characters for internal lot control

Additional Detailed Technical Information	
<i>additional information is available on our dash board. To access this information click here</i>	
Performance Data	Data Table
	Swept Graphs
	S-Parameter (S2P Files) Data Set (.zip file)
Case Style	DQ1225 <i>Plastic package, exposed paddle lead finish: Matte-Tin</i>
Tape & Reel Standard quantities available on reel	F66 <i>7" reels with 20, 50, 100, 200, 500 or 1K devices</i>
Suggested Layout for PCB Design	PL-594
Evaluation Board	TB-1063-13LN+
Environmental Ratings	ENV08T9

ESD Rating

Human Body Model (HBM): Class 1B (Pass 500 V) in accordance with ANSI/ESD STM 5.1 - 2001

MSL Rating

Moisture Sensitivity: MSL1 in accordance with IPC/JEDEC J-STD-020D

MSL Test Flow Chart

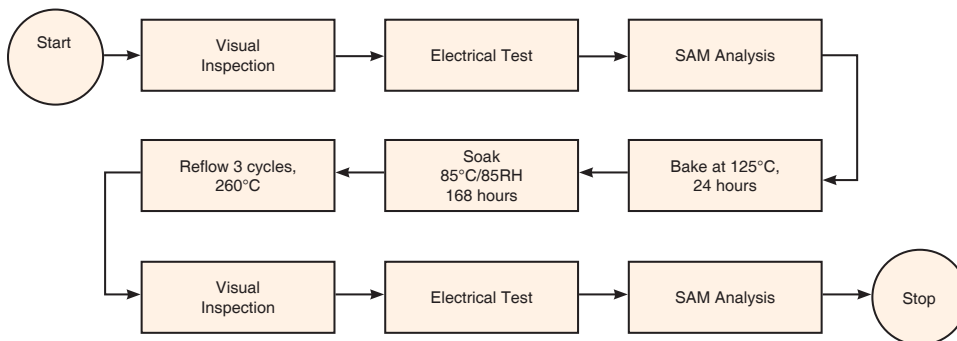

Additional Notes

- A. Performance and quality attributes and conditions not expressly stated in this specification document are intended to be excluded and do not form a part of this specification document.
- B. Electrical specifications and performance data contained in this specification document are based on Mini-Circuit's applicable established test performance criteria and measurement instructions.
- C. The parts covered by this specification document are subject to Mini-Circuits standard limited warranty and terms and conditions (collectively, "Standard Terms"); Purchasers of this part are entitled to the rights and benefits contained therein. For a full statement of the Standard Terms and the exclusive rights and remedies thereunder, please visit Mini-Circuits' website at www.minicircuits.com/MCLStore/terms.jsp



X-ON Electronics

Largest Supplier of Electrical and Electronic Components

Click to view similar products for [RF Amplifier](#) category:

Click to view products by [Mini-Circuits](#) manufacturer:

Other Similar products are found below :

[A82-1](#) [BGA622H6820XTSA1](#) [BGA 728L7 E6327](#) [BGB719N7ESDE6327XTMA1](#) [HMC397-SX](#) [HMC405](#) [HMC561-SX](#) [HMC8120-SX](#)
[HMC8121-SX](#) [HMC-ALH382-SX](#) [HMC-ALH476-SX](#) [SE2433T-R](#) [SMA3101-TL-E](#) [SMA39](#) [A66-1](#) [A66-3](#) [A67-1](#) [LX5535LQ](#) [LX5540LL](#)
[MAAM02350](#) [HMC3653LP3BETR](#) [HMC549MS8GETR](#) [HMC-ALH435-SX](#) [SMA101](#) [SMA32](#) [SMA411](#) [SMA531](#) [SST12LP17E-XX8E](#)
[SST12LP19E-QX6E](#) [WPM0510A](#) [HMC5929LS6TR](#) [HMC5879LS7TR](#) [HMC1126](#) [HMC1087F10](#) [HMC1086](#) [HMC1016](#) [SMA1212](#)
[MAX2689EWS+T](#) [MACS-007802-0M1RS0](#) [MAAMSS0041TR](#) [MAAM37000-A1G](#) [CHA5115-QDG](#) [SMA70-2](#) [SMA4011](#) [A231](#) [HMC-](#)
[AUH232](#) [LX5511LQ](#) [LX5511LQ-TR](#) [HMC7441-SX](#) [HMC-ALH310](#)