

Ultra High Dynamic Range

# Monolithic Amplifier

LHA-1+

50Ω 0.05 to 6 GHz

## The Big Deal

- Ultra High IP3
- Broadband High Dynamic Range without external Matching Components



Generic photo used for illustration purposes only

MCLP PACKAGE

## Product Overview

LHA-1+ (RoHS compliant) is an advanced wideband amplifier fabricated using E-PHEMT technology and offers extremely high dynamic range over a broad frequency range and with low noise figure. In addition, the LHA-1+, unlike competitive models, is well matched (input and output) over a broad frequency range without the need for external matching components. Lead finish is tin-silver over nickel. It is enclosed in a 3x3 mm MCLP package for low parasitic interface.

## Key Features

Feature	Advantages
Broad Band: 0.05 to 6.0 GHz	Broadband covering primary wireless communications bands: Cellular, PCS, LTE, WiMAX
Extremely High IP3 versus DC power Consumption 40 dBm typical at 2 GHz	The LHA-1+ matches industry leading IP3 performance relative to device size and power consumption. The combination of the design and E-PHEMT Structure provides enhanced linearity over a broad frequency range as evidence in the IP3 being typically 17 dB above the P 1dB point. This feature makes this amplifier ideal for use in: <ul style="list-style-type: none"><li>• Driver amplifiers for complex waveform up converter paths</li><li>• Drivers in linearized transmit systems</li><li>• Secondary amplifiers in ultra High Dynamic range receivers</li></ul>
No External Matching Components Required	LHA-1+ provides Input and Output Return Loss of 10-21 dB up to 4 GHz without the need for any external matching components
Low Noise Figure: 2.6dB typ. up to 4 GHz 3.4dB typ. up to 6 GHz	A unique feature of the LHA-1+ which separates this design from all competitors is the low noise figure performance in combination with the high dynamic range.



Ultra High Dynamic Range

# Monolithic Amplifier

0.05-6 GHz

## Product Features

- High IP3, 40 dBm typ. at 2 GHz, 5V
- Gain, 14.1 dB typ. at 2 GHz, 5V
- High Pout, P1dB 22.7 dBm typ. at 2 GHz, 5V
- Low noise figure, 2.1 dB @2 GHz, 5V
- Usable to 4.0V
- No external matching components required



Generic photo used for illustration purposes only

## LHA-1+

CASE STYLE: FG873

**+RoHS Compliant**

The +Suffix identifies RoHS Compliance. See our web site for RoHS Compliance methodologies and qualifications

## Typical Applications

- Base station infrastructure
- Portable Wireless
- CATV & DBS
- MMDS & Wireless LAN
- LTE

## General Description

LHA-1+ (RoHS compliant) is an advanced wideband amplifier fabricated using E-PHEMT technology and offers extremely high dynamic range over a broad frequency range and with low noise figure. In addition, the LHA-1+ has well matched input and output over a broad frequency range without the need for external matching components. Lead finish is tin-silver over nickel. It has repeatable performance from lot to lot and is enclosed in a 3 x 3 mm MCLP package for low parasitic interface.

### simplified schematic and pin description

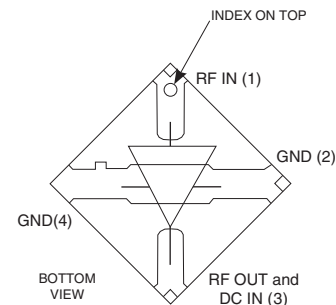
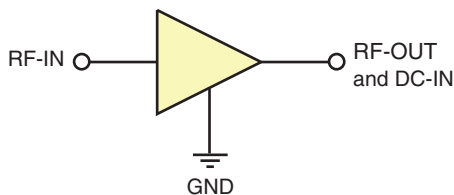

Function	Pin Number	Description
RF IN	1	RF input pin. This pin requires the use of an external DC blocking capacitor chosen for the frequency of operation.
RF-OUT and DC-IN	3	RF output and bias pin. DC voltage is present on this pin; therefore a DC blocking capacitor is necessary for proper operation. An RF choke is needed to feed DC bias without loss of RF signal due to the bias connection, as shown in "Recommended Application Circuit", Fig. 2
GND	2,4	Connections to ground. Use via holes as shown in "Suggested Layout for PCB Design" to reduce ground path inductance for best performance.



**Electrical Specifications<sup>1</sup> at 25°C, unless noted**

Parameter	Condition (GHz)	Vd=5.0V			Vd=4.5V	Vd=4.0V	Units
		Min.	Typ.	Max.	Typ.	Typ.	
Frequency Range		0.05		6	0.05-6	0.05-6	GHz
Gain	0.05	15.4	17.6	19.4	17.4	17.1	dB
	0.8	14.1	16.0	17.3	15.7	15.4	
	2.0	—	14.1	—	13.9	13.5	
	3.0	—	12.5	—	12.2	11.9	
	4.0	9.6	11.1	12.3	10.9	10.6	
	6.0	—	9.2	—	9.0	8.7	
Input Return Loss	0.05	—	11.2	—	11.2	11.1	dB
	0.8	13.0	15.8	—	15.8	15.6	
	2.0	—	11.5	—	11.5	11.3	
	3.0	—	10.4	—	10.4	10.2	
	4.0	—	10.1	—	10.2	10.1	
	6.0	—	9.0	—	9.0	9.0	
Output Return Loss	0.05	—	14.1	—	14.0	13.8	dB
	0.8	13.0	20.8	—	20.1	19.3	
	2.0	—	15.8	—	15.4	14.6	
	3.0	—	13.9	—	13.6	13.1	
	4.0	—	12.8	—	12.7	12.3	
	6.0	—	12.0	—	12.8	11.3	
Reverse Isolation	2.0		19.3		19.1	18.7	dB
Output Power @1 dB compression	0.05	20.0	22.8	—	21.6	20.1	dBm
	0.8	20.0	22.6	—	21.5	20.0	
	2.0	20.0	22.7	—	21.6	20.1	
	3.0	—	23.0	—	21.9	20.4	
	4.0	—	22.9	—	21.9	20.4	
	6.0	—	22.5	—	21.6	20.1	
Output IP3	0.05	—	40.3	—	39.0	35.2	dBm
	0.8	37.0	39.6	—	39.7	35.9	
	2.0	—	39.5	—	37.3	33.1	
	3.0	—	39.6	—	37.0	32.7	
	4.0	—	39.0	—	36.7	32.3	
	6.0	—	38.0	—	35.8	31.5	
Noise Figure	0.05		1.8		1.7	1.7	dB
	0.8		2.0		2.0	2.0	
	2.0		2.1		2.0	2.0	
	3.0		2.3		2.2	2.2	
	4.0		2.6		2.4	2.4	
	6.0		3.4		3.2	3.0	
Device Operating Voltage		4.8	5.0	5.2	4.5	4.0	V
Device Operating Current		110	146	180	114	87	mA
Device Current Variation vs. Temperature <sup>(2)</sup>			116		138	138	μA/°C
Device Current Variation vs Voltage		116	0.057	—	0.055	0.055	mA/mV
Thermal Resistance, junction-to-ground lead			59		59	59	°C/W

<sup>(1)</sup> Measured on Mini-Circuits Characterization test board TB-784+. See Characterization Test Circuit (Fig. 1)

<sup>(2)</sup> (Current at 85°C — Current at -45°C)/130

**Absolute Maximum Ratings**

Parameter	Ratings
Operating Temperature (ground lead)	-40°C to 85°C
Storage Temperature	-65°C to 150°C
Operating Current at 5V	210 mA
Power Dissipation	1 W
Input Power (CW)	24 dBm
DC Voltage on Pin 3	6 V

Note:

Permanent damage may occur if any of these limits are exceeded.

Electrical maximum ratings are not intended for continuous normal operation.

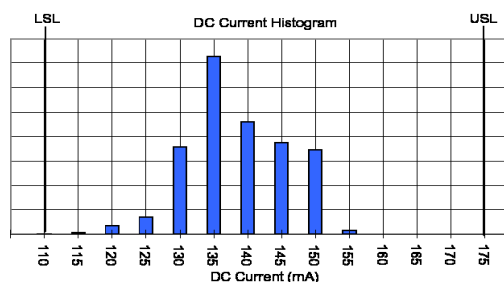

**Characterization Test Circuit**

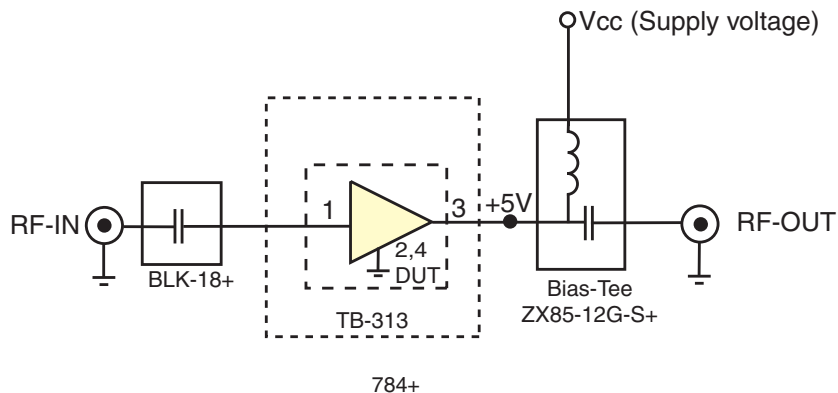
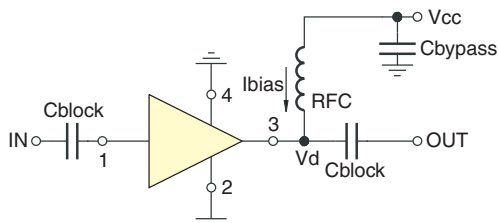

**Fig 1.** Block Diagram of Test Circuit used for characterization. (DUT soldered on Mini-Circuits Characterization test board TB-784+) Gain, Return loss, Output power at 1dB compression (P1 dB) , output IP3 (OIP3) and noise figure measured using Agilent’s N5242A PNA-X microwave network analyzer.

**Conditions:**

1. Gain and Return loss: Pin= -25dBm
2. Output IP3 (OIP3): Two tones, spaced 1 MHz apart, 5 dBm/tone at output.

**Recommended Application Circuit**



*Fig 2. Test Board includes case, connectors, and components soldered to PCB*

**Product Marking**

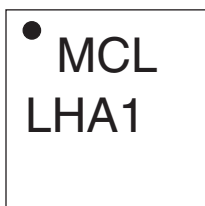

Additional Detailed Technical Information	
<i>additional information is available on our dash board. To access this information <a href="#">click here</a></i>	
<b>Performance Data</b>	Data Table
	Swept Graphs
	S-Parameter (S2P Files) Data Set (.zip file)
<b>Case Style</b>	FG873 (3x3 mm MCLP) <i>Plastic package, exposed paddle lead finish: tin-silver over nickel</i>
<b>Tape &amp; Reel</b> Standard quantities available on reel	F68 <i>7" reels with 20, 50, 100, 200, 500 or 1K devices 13" Reels with 2K, 3K, 4K devices</i>
<b>Suggested Layout for PCB Design</b>	PL-443
<b>Evaluation Board</b>	TB-819+
<b>Environmental Ratings</b>	ENV08T1

**ESD Rating**

Human Body Model (HBM): Class 1A (250 to <500V) in accordance with ANSI/ESD STM 5.1 - 2001

Machine Model (MM): Class M1 (>25V) in accordance with ANSI/ESD STM5.2-1999

**MSL Rating**

Moisture Sensitivity: MSL1 in accordance with IPC/JEDEC J-STD-020D

**MSL Test Flow Chart**

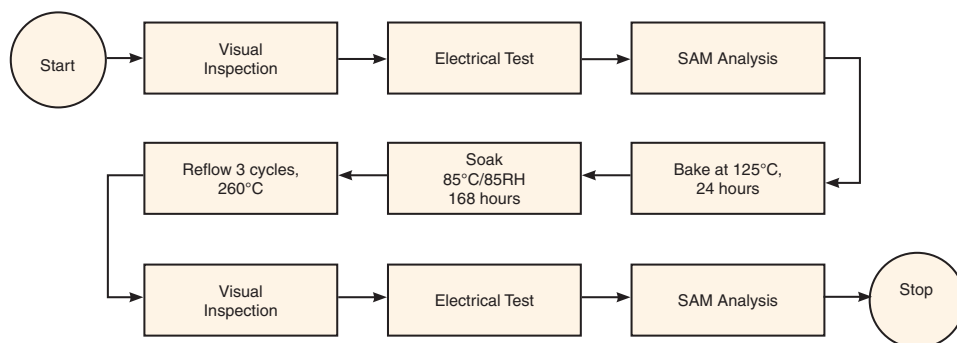

**Additional Notes**

- A. Performance and quality attributes and conditions not expressly stated in this specification document are intended to be excluded and do not form a part of this specification document.
- B. Electrical specifications and performance data contained in this specification document are based on Mini-Circuit's applicable established test performance criteria and measurement instructions.
- C. The parts covered by this specification document are subject to Mini-Circuits standard limited warranty and terms and conditions (collectively, "Standard Terms"); Purchasers of this part are entitled to the rights and benefits contained therein. For a full statement of the Standard Terms and the exclusive rights and remedies thereunder, please visit Mini-Circuits' website at [www.minicircuits.com/MCLStore/terms.jsp](http://www.minicircuits.com/MCLStore/terms.jsp)

## X-ON Electronics

Largest Supplier of Electrical and Electronic Components

*Click to view similar products for [RF Amplifier](#) category:*

*Click to view products by [Mini-Circuits](#) manufacturer:*

Other Similar products are found below :

[A82-1](#) [BGA622H6820XTSA1](#) [BGA 728L7 E6327](#) [BGB719N7ESDE6327XTMA1](#) [HMC397-SX](#) [HMC405](#) [HMC561-SX](#) [HMC8120-SX](#)  
[HMC8121-SX](#) [HMC-ALH382-SX](#) [HMC-ALH476-SX](#) [SE2433T-R](#) [SMA3101-TL-E](#) [SMA39](#) [A66-1](#) [A66-3](#) [A67-1](#) [LX5535LQ](#) [LX5540LL](#)  
[MAAM02350](#) [HMC3653LP3BETR](#) [HMC549MS8GETR](#) [HMC-ALH435-SX](#) [SMA101](#) [SMA32](#) [SMA411](#) [SMA531](#) [SST12LP17E-XX8E](#)  
[SST12LP19E-QX6E](#) [WPM0510A](#) [HMC5929LS6TR](#) [HMC5879LS7TR](#) [HMC1126](#) [HMC1087F10](#) [HMC1086](#) [HMC1016](#) [SMA1212](#)  
[MAX2689EWS+T](#) [MACS-007802-0M1RS0](#) [MAAMSS0041TR](#) [MAAM37000-A1G](#) [CHA5115-QDG](#) [SMA70-2](#) [SMA4011](#) [A231](#) [HMC-](#)  
[AUH232](#) [LX5511LQ](#) [LX5511LQ-TR](#) [HMC7441-SX](#) [HMC-ALH310](#)