



5 VOLT-SURFACE MOUNT

Monolithic Amplifier

LHY-84+

50Ω DC to 7 GHz

THE BIG DEAL

- High Gain, 24.4 dB typ. at 10 MHz
- High P1dB, 20.8 dB typ. at 10 MHz
- High IP3, +38.5 dBm typ. at 10 MHz
- Small size, 2 x 2mm
- Ruggedized design
- Fixed 5V operation
- Unconditionally stable
- Excellent ESD Protection
- Transient protected, US patent 6,943,629

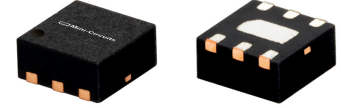

Generic photo used for illustration purposes only

CASE STYLE: MC1630-1

+RoHS Compliant

The +Suffix identifies RoHS Compliance. See our website for methodologies and qualifications

APPLICATIONS

- Base station infrastructure
- Portable Wireless
- CATV & DBS
- MMDS & Wireless LAN
- LTE

PRODUCT OVERVIEW

LHY-84+ (RoHS compliant) is a wideband amplifier offering high dynamic range. Lead finish is matte-tin. It has repeatable performance from lot to lot and is enclosed in a 2mm x 2mm MCLP package. It uses patented Transient Protected Darlington configuration and is fabricated using InGaP HBT technology.

KEY FEATURES

Feature	Advantages
Broad Band: DC to 7 GHz	Broadband covering primary wireless communications bands: CATV & DBS, MMDS & Wireless LAN, LTE
Combination of high P1dB & OIP3: P1dB, +20.8 dBm at 10 MHz OIP3, +38.5 dBm at 10 MHz	The LHY-84+ matches industry leading IP3 performance relative to device size and power consumption. IP3 is typically 12-18 dB above the P1dB point. This feature makes this amplifier ideal for use in: <ul style="list-style-type: none"> • Driver amplifiers for complex waveform up converter paths • Drivers in linearized transmit systems • Secondary amplifiers in ultra High Dynamic range receivers
High Gain, 24 dB typ. at 100 MHz	Minimizes number of stages, PCB space and cost to achieve high gain.
Small 2 x 2mm, 6-lead MCLP package	Tiny footprint saves space in dense layouts while providing low inductance, repeatable transitions, and excellent thermal contact to the PCB.

REV. A
ECO-013495
LHY-84+
GY/CP
220531





5 VOLT-SURFACE MOUNT

Monolithic Amplifier

LHY-84+

Mini-Circuits

50Ω DC to 7 GHz

ELECTRICAL SPECIFICATIONS AT 25°C, +5V & 50Ω, UNLESS NOTED OTHERWISE

Parameter	Condition (MHz)	Vd=5V ¹			Vd=5V ²	Units
		Min.	Typ.	Max.	Typ.	
Frequency Range ⁶		DC		7	DC-7	GHz
Gain	10	22	24.4	26.8	24.3	dB
	1000	20.5	22.8	25.1	22.7	
	2000	17.9	20.0	21.9	19.9	
	4000	13.4	15.7	16.4	14.5	
	6000	—	11.8	—	9.9	
	7000	—	9.8	—	7.9	
Input Return Loss	10	18	24	—	22	dB
	1000	13	17	—	18	
	2000	10	15	—	15	
	4000	—	15	—	11	
	6000	—	14	—	10	
	7000	—	12	—	9	
Output Return Loss	10	16	22	—	20	dB
	1000	—	9	—	9	
	2000	—	6	—	6	
	4000	—	6	—	5	
	6000	—	6	—	5	
	7000	—	5	—	6	
Reverse Isolation	2000		28		28	dB
Output Power @1dB Compression	10		20.8		20.1	dBm
	1000		21.0		20.7	
	2000		21.1		20.6	
	4000		19.6		19.0	
	6000		16.8		15.5	
	7000		15.5		14.0	
Output IP ₃ ³	10	32.3	38.5	—	36.7	dBm
	1000	30.6	34.4	—	34.5	
	2000	28.7	33.1	—	33.5	
	4000	—	31.1	—	30.8	
	6000	—	29.7	—	27.7	
	7000	—	27.9	—	26.8	
Noise Figure	10		5.1		5.1	dB
	1000		5.2		5.1	
	2000		5.4		5.5	
	4000		5.6		5.9	
	6000		6.1		6.4	
	7000		6.5		6.9	
Device Operating Voltage		+4.75	+5.0	+5.25	+5.0	V
Device Operating Current			111	130	106	mA
Device Current Variation vs. Temperature ⁴			78		78	μA/°C
Device Current Variation vs Voltage ⁵			0.057		0.055	mA/mV
Thermal Resistance, Junction-to-Ground Lead at 85°C Stage Temp.			64		64	°C/W

1. Measured on Mini-Circuits Characterization test board TB-621+. See Characterization Test Circuit (Fig. 1)

2. Measured on Mini-Circuits Application test board TB-1064+. See Characterization Test Circuit (Fig. 2)

3. Tested at P_{out}=0dBm / tone.

4. (Current at 85°C – Current at -45°C)/130

5. (Current at +5.25V-current - Current at +4.75V)/1000

6. Guaranteed specifications DC-7 GHz. Low frequency cut-off determined by external coupling capacitors and external bias choke.





MAXIMUM RATINGS⁷

Parameter	Ratings
Operating Temperature (ground lead)	-40°C to 85°C
Storage Temperature	-65°C to 150°C
Power Dissipation	1W
Input Power (CW)	+13 dBm
DC Voltage on Pad 5	+5.8V

7. Permanent damage may occur if any of these limits are exceeded. Electrical maximum ratings are not intended for continuous normal operation.

SIMPLIFIED SCHEMATIC AND PIN DESCRIPTION

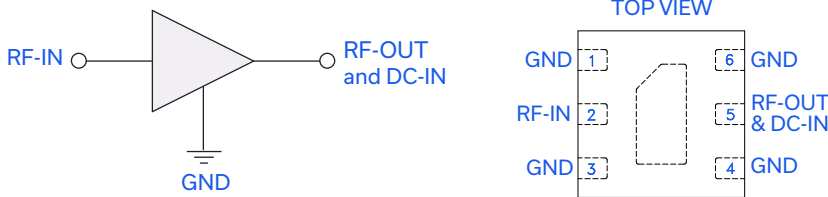

Function	Pin Number	Description
RF-IN	2	RF input pin. This pin requires the use of an external DC blocking capacitor chosen for the frequency of operation
RF-OUT and DC-IN	5	RF output and bias pin. DC voltage is present on this pin; therefore a DC blocking capacitor is necessary for proper operation. An RF choke is needed to feed DC bias without loss of RF signal due to the bias connection, as shown in "Recommended Application Circuit", Fig. 2
GND	1,3,4,6 & paddle	Connections to ground. Use via holes as shown in "Suggested Layout for PCB Design" to reduce ground path inductance for best performance.



5 VOLT-SURFACE MOUNT

Monolithic Amplifier

LHY-84+

50Ω DC to 7 GHz

CHARACTERIZATION TEST CIRCUIT

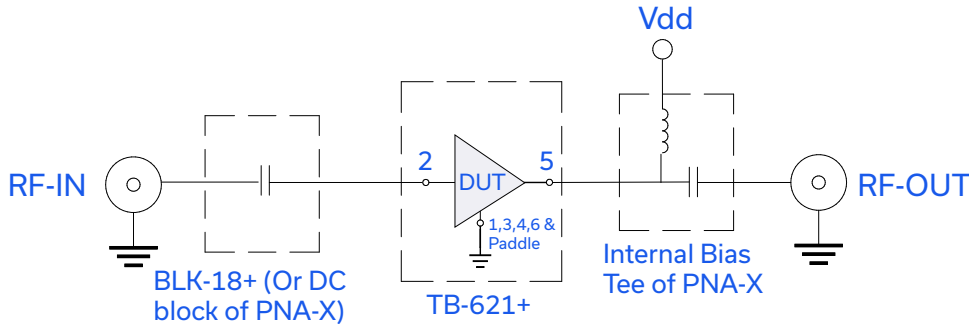

Fig 1. Characterization Circuit

Note: This block diagram is used for characterization. (DUT soldered on Mini-Circuits Characterization test board TB-621+)

Gain, Return loss, Output power at 1dB compression (P1 dB), output IP3 (OIP3) and noise figure measured using Agilent's N5242A PNA-X microwave network analyzer.

Conditions:

1. Gain and Return loss: Pin= -25dBm
2. Output IP3 (OIP3): Two tones, spaced 1 MHz apart, 0 dBm/tone at output.

RECOMMENDED APPLICATION CIRCUIT

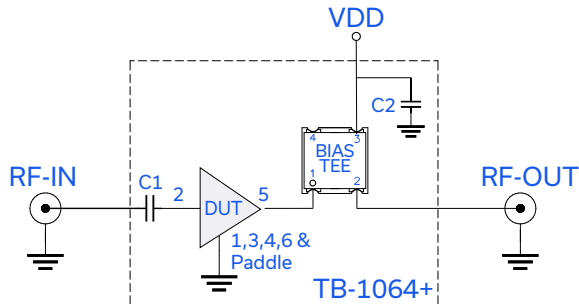

Component	P/N	Supplier	Value	Size
DUT	LHY-84+	MCL	--	2x2 mm
C1	LBB0402X104MGT1C8	Presidio	0.1uF	0402
C2	GRM188R71H103KA01D	Murate	0.01uF	0603
Bias-Tee	TCBT-123+	MCL	--	0.15"x0.15"

Fig 2. Application Circuit

Note: (DUT soldered on Mini-Circuits Application test board TB-1064+). TB-1064+ uses a three layer PCB, see drawing.

Gain, Return loss, Output power at 1dB compression (P1 dB), output IP3 (OIP3) and noise figure measured using Agilent's N5242A PNA-X microwave network analyzer.

Conditions:

1. Gain and Return loss: Pin= -25dBm
2. Output IP3 (OIP3): Two tones, spaced 1 MHz apart, 0 dBm/tone at output.

PRODUCT MARKING

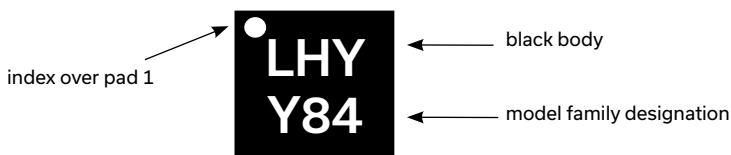

Marking may contain other features or characters for internal lot control





5 VOLT-SURFACE MOUNT

Monolithic Amplifier

LHY-84+

Mini-Circuits

50Ω DC to 7 GHz

ADDITIONAL DETAILED TECHNICAL INFORMATION IS AVAILABLE ON OUR DASH BOARD. TO ACCESS [CLICK HERE](#)

Performance Data	Data Table Swept Graphs S-Parameter (S2P Files) Data Set (.zip file)
Case Style	MC1630-1 Plastic package, exposed paddle lead finish: Matte Tin
Tape & Reel Standard quantities available on reel	F66 7" reels with 20, 50, 100, 200, 500, 1K, or 2K devices.
Suggested Layout for PCB Design	PL-593
Evaluation Board	TB-1064+
Environmental Ratings	ENV08T1

ESD RATING

Human Body Model (HBM): Class 1C (Pass 1000V) in accordance with ANSI/ESD STM 5.1 - 2001

MSL RATING

Moisture Sensitivity: MSL1 in accordance with IPC/JEDEC J-STD-020D

MSL TEST FLOW CHART

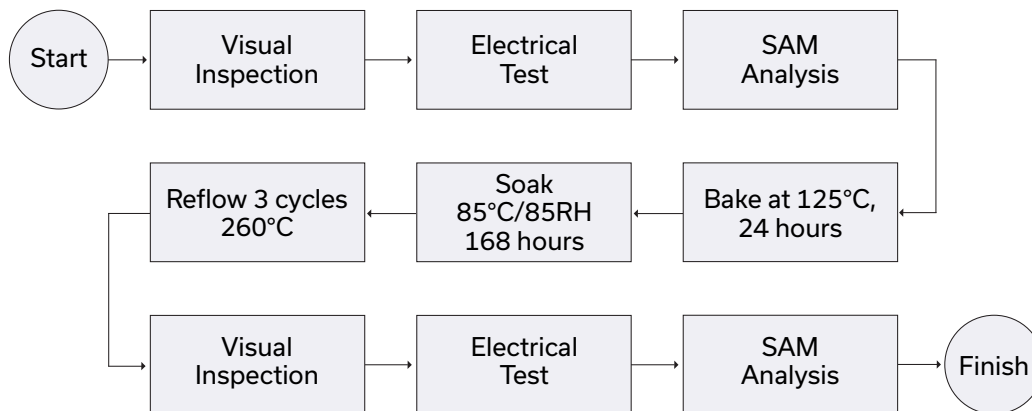

- NOTES
- A. Performance and quality attributes and conditions not expressly stated in this specification document are intended to be excluded and do not form a part of this specification document.
 - B. Electrical specifications and performance data contained in this specification document are based on Mini-Circuit's applicable established test performance criteria and measurement instructions.
 - C. The parts covered by this specification document are subject to Mini-Circuits standard limited warranty and terms and conditions (collectively, "Standard Terms"); Purchasers of this part are entitled to the rights and benefits contained therein. For a full statement of the standard terms and the exclusive rights and remedies thereunder, please visit Mini-Circuits' website at www.minicircuits.com/terms/viewterm.html



X-ON Electronics

Largest Supplier of Electrical and Electronic Components

Click to view similar products for [RF Amplifier](#) category:

Click to view products by [Mini-Circuits](#) manufacturer:

Other Similar products are found below :

[A1212](#) [AL7](#) [SE2433T-R](#) [SMA3101-TL-E](#) [A66-1](#) [A66-3](#) [A81-2](#) [LX5535LQ](#) [SMA411](#) [SMA531](#) [SST12LP19E-QX6E](#) [WPM0510A](#)
[MMZ25332B4T1](#) [SMA1212](#) [MAAMSS0041TR](#) [MAAM37000-A1G](#) [SMA88-1](#) [SMA4011](#) [A231](#) [UA5M20MC](#) [XD1001-BD-000V](#)
[BGU6009/N2X](#) [BGS8H2X](#) [BGS8324Z](#) [SMA66](#) [A12](#) [MMA022AA](#) [MAAP-015024-DIE](#) [AMS-162-PIN](#) [CA70-2](#) [MMG30301BT1](#) [LA17](#)
[MMA041PP5](#) [MAMF-011119-TR1000](#) [A57](#) [GRF2011](#) [MMA044PP3](#) [ISL55007IEZ-T7](#) [ISL55008IEZ-T7](#) [ISL55009IEZ-T7](#) [ISL55010IEZ-](#)
[T7](#) [ISL55011IEZ-T7](#) [NSVG3117SG6T1G](#) [BGA7H1BN6E6327](#) [TRF1305B2RYPR](#) [TRF1208RPVT](#) [LTC6433AIUF-15#PBF](#)
[HMC797APM5ETR-R5](#) [HMC565LC5TR-R5](#) [HMC8413LP2FE](#)