

50Ω 10 to 24 GHz

### The Big Deal

- Wideband, 10 to 24 GHz
- Low insertion loss, 1.0 dB typ. to 20 GHz
- Low unbalance, 0.7 dB, 6°
- Power handling up to +31 dBm



CASE STYLE: MC1630-1

### Product Overview

Mini-Circuits MTY2-243+ is a wideband MMIC balun transformer with an impedance ratio of 2:1 covering a wide range of applications from 10 to 24 GHz. Fabricated using HBT process technology, this model provides outstanding repeatability with low insertion loss, low amplitude unbalance, low phase unbalance, and RF input power handling up to +31 dBm (1.25W). The unit comes housed in a tiny 2x2x1mm QFN package with low inductance, excellent thermal efficiency, and high ESD rating.

### Key Features

Feature	Advantages
Wideband, 10 to 24 GHz	MTY2-243+ supports a broad variety of applications including instrumentation, radar, SATCOM and more.
Low insertion loss <ul style="list-style-type: none"> <li>• 1.0 dB, 10 to 20 GHz</li> <li>• 1.5 dB, 20 to 24 GHz</li> </ul>	Enables excellent signal power transmission from input to output.
Low unbalance <ul style="list-style-type: none"> <li>• 0.7 dB amplitude unbalance</li> <li>• 6° phase unbalance</li> </ul>	Low unbalance can improve a system's electromagnetic compatibility by rejecting unwanted common-mode noise.
Tiny size, 2 x 2 x 1mm	Accommodates tight space requirements for dense PCB layouts.

# MMIC Balun RF Transformer

## MTY2-243+

50Ω 10 to 24 GHz

### Features

- wideband, 10 to 24 GHz
- low phase unbalance, 6 deg. and amplitude unbalance, 0.7 dB typ.
- miniature size, (2 x 2 x 1 mm)
- low cost
- aqueous washable

### Applications

- Radar
- SATCOM
- Instrumentation



Generic photo used for illustration purposes only  
CASE STYLE: MC1630-1

#### +RoHS Compliant

The +Suffix identifies RoHS Compliance. See our web site for RoHS Compliance methodologies and qualifications

### Electrical Specifications at 25°C

Parameter	Frequency (GHz)	Min.	Typ.	Max.	Unit
Impedance Ratio			2		
Frequency Range		10		24	GHz
Insertion Loss <sup>1</sup>	10-12	—	1.0	1.7	dB
	12-15	—	1.0	1.5	
	15-20	—	1.0	1.7	
	20-24	—	1.5	2.2	
Amplitude Unbalance	10-12		0.7		dB
	12-15		0.3		
	15-20		0.7		
	20-24		0.4		
Phase Unbalance <sup>3</sup>	10-12		5.8		Degree
	12-15		6.4		
	15-20		5.5		
	20-24		2.9		

1. Above 3dB theoretical.

2. Relative to 180°

### Maximum Ratings

Parameter	Ratings
Operating Temperature	-40°C to 85°C
Storage Temperature	-65°C to 150°C
Input RF Power	31 dBm

Permanent damage may occur if any of these limits are exceeded.

### Pad Connections

Function	Pad Number
PRIMARY DOT (Unbalanced Port)	2
SECONDARY DOT (Balanced)	6
SECONDARY (Balanced)	4
GND	1,3 & paddle
NC (grounded on TB)	5

### Configuration J

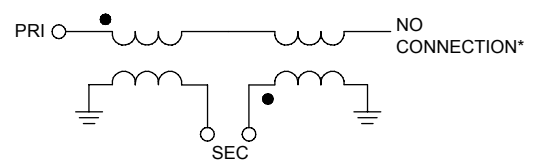

Characterization Test Circuit

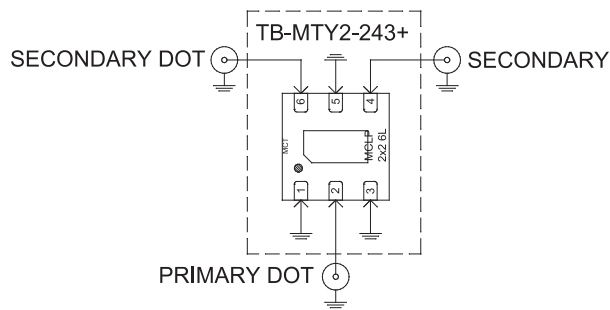

Fig 1. Application and Characterization Circuit

Note: This block diagram is used for characterization. (DUT is soldered on Mini-Circuits Characterization test board TB-MTY2-243+) Insertion loss, Unbalance & Return loss measured using Keysight's N5242A PNA-X microwave network analyzer.

Conditions:

- 1. Insertion loss, Unbalance, and Return loss: Pin=-25dBm

Product Marking



Marking may contain other features or characters for internal lot control

<b>Additional Detailed Technical Information</b>	
<i>additional information is available on our dash board. To access this information <a href="#">click here</a></i>	
<b>Performance Data</b>	Data Table
	Swept Graphs
	S-Parameter (S2P Files) Data Set (.zip file)
<b>Case Style</b>	MC1630-1 <i>Plastic package, exposed paddle lead finish: Matte-Tin</i>
<b>Tape &amp; Reel</b> Standard quantities available on reel	F66 <i>7" reels with 20, 50, 100, 200, 500 or 1K devices</i>
<b>Suggested Layout for PCB Design</b>	PL-656
<b>Evaluation Board</b>	TB-MTY2-243+ & TB-MTY2-243C+
<b>Environmental Ratings</b>	ENV08T1

**ESD Rating**

Human Body Model (HBM): Class 1A (Pass 250 V) in accordance with ANSI/ESD STM 5.1 - 2001

**MSL Test Flow Chart**

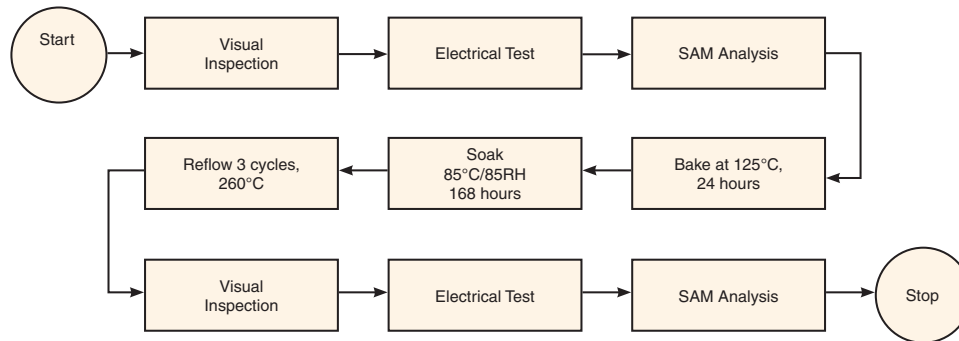

**Additional Notes**

- A. Performance and quality attributes and conditions not expressly stated in this specification document are intended to be excluded and do not form a part of this specification document.
- B. Electrical specifications and performance data contained in this specification document are based on Mini-Circuit's applicable established test performance criteria and measurement instructions.
- C. The parts covered by this specification document are subject to Mini-Circuits standard limited warranty and terms and conditions (collectively, "Standard Terms"); Purchasers of this part are entitled to the rights and benefits contained therein. For a full statement of the Standard Terms and the exclusive rights and remedies thereunder, please visit Mini-Circuits' website at [www.minicircuits.com/MCLStore/terms.jsp](http://www.minicircuits.com/MCLStore/terms.jsp)

## X-ON Electronics

Largest Supplier of Electrical and Electronic Components

*Click to view similar products for [Signal Conditioning](#) category:*

*Click to view products by [Mini-Circuits](#) manufacturer:*

Other Similar products are found below :

[MAPDCC0001](#) [MAPDCC0004](#) [PD0409J5050S2HF](#) [880157](#) [HHS-109-PIN](#) [DC1417J5005AHF](#) [AFS14A30-2185.00-T3](#) [AFS14A35-1591.50-T3](#) [DS-323-PIN](#) [B39321R801H210](#) [1A0220-3](#) [JP510S](#) [LFB212G45SG8C341](#) [LFB322G45SN1A504](#) [LFL182G45TC3B746](#) [SF2159E](#) [30057](#)  
[FM-104-PIN](#) [CER0813B](#) [MAPDCC0005](#) [3A325](#) [40287](#) [41180](#) [ATB3225-75032NCT](#) [BD0810N50100AHF](#) [BD2425J50200AHF](#)  
[C5060J5003AHF](#) [JHS-115-PIN](#) [JP503AS](#) [DC0710J5005AHF](#) [DC2327J5005AHF](#) [DC3338J5005AHF](#) [43020](#) [LFB2H2G60BB1C106](#)  
[LFL15869MTC1B787](#) [X3C19F1-20S](#) [XC3500P-20S](#) [10013-20](#) [SF2194E](#) [CDBLB455KCAX39-B0](#) [TGL2208-SM, EVAL](#) [RF1353C](#)  
[PD0922J5050D2HF](#) [1E1305-3](#) [1G1304-30](#) [B0922J7575AHF](#) [2020-6622-20](#) [TP-102-PIN](#) [TP-103-PIN](#) [BD1222J50200AHF](#)