



SURFACE MOUNT MMIC

Dual Matched Amplifier

PHA-11+

50Ω .05 to 3 GHz

THE BIG DEAL

- Two matched amplifiers in one package
- High IP3, +44 dBm at 0.8 GHz in push-pull configuration
- Low supply voltage, 3 to 5V
- Noise Figure, 1.8 at 0.8 GHz
- Gain, 16 dB typ. at 0.8 GHz
- P1dB, +22 dBm typ. at 0.8 GHz
- May be used as replacement for WJ AH11^{a,b}
- High IP2, +78 dBm at 0.8 in push-pull configuration

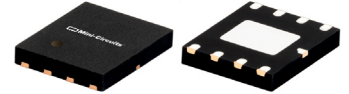

Generic photo used for illustration purposes only

CASE STYLE: DL1020

+RoHS Compliant

The +Suffix identifies RoHS Compliance. See our web site for RoHS Compliance methodologies and qualifications

APPLICATIONS

- CATV
- FTTH
- Optical networks
- Base station infrastructure
- Balanced amplifiers
- 75 Ohm push-pull and balanced amplifiers

PRODUCT OVERVIEW

Mini-Circuits PHA-11+ is a dual matched wideband amplifier fabricated using advanced E-PHEMT* technology, offering high dynamic range (High IP3 and Low NF) for use in 50 and 75 ohm applications. Exceptionally high IP2 has been demonstrated in wideband 50 and 75 ohm amplifiers evaluation boards. Combining this with low noise figure to enable it for use in exceptionally high dynamic range amplifiers.

KEY FEATURES

Feature	Advantages
Broadband	Covers Cable TV band and communication bands such as Cellular, Cable TV, PCS, WiMAX etc.
Matched pair for use in exceptionally high IP3 and IP2 amplifiers	Typical gain match of 0.2 dB and phase match of 1.6 deg. enables it to be used in push-pull amplifiers. Outstanding IP2.
High IP3, up to 43 dBm	Ideal for suppressing unwanted intermods in the presence of multi carriers, which is common in present day communication systems.
Low Noise Figure: 1.8 dB typical	Compare this to competitors, which in the range of 4-6 dB. Mini-Circuits amplifier improves the dynamic range.
High P1dB: 22 dBm	High P1dB enables the amplifier to operate in linear region in the presence of strong interfering signals.

* Enhancement mode pseudomorphic High Electron Mobility Transistor.

a. Suitability for model replacement within a particular system must be determined by and is solely the responsibility of the customer based on, among other things, electrical performance criteria, stimulus conditions, application, compatibility with other components and environmental conditions and stresses.

b. The WJ part number is used for identification and comparison purposes only.

REV. C
ECO-010399
PHA-11+
MCL NY
211102



Dual Matched Amplifier **PHA-11+****ELECTRICAL SPECIFICATIONS¹ AT 25°C, Z₀=50Ω AND DEVICE VOLTAGE 5V, UNLESS NOTED**

(Specifications (other than Matching or where defined as push-pull) are for each of the two matched amplifiers in the package)

Parameter		Condition (GHz)	Min.	Typ.	Max.	Units
Frequency Range			0.05		3.0	GHz
Gain		0.05	—	17.7	—	dB
		0.25	—	16.4	—	
		0.45	—	16.3	—	
		0.8	14.5	16.1	17.7	
		2.0	—	14.5	—	
		3.0	—	12.0	—	
Input Return Loss		0.05		11.3		dB
		0.25		19.5		
		0.45		19.4		
		0.8		17.0		
		2.0		8.4		
		3.0		4.5		
Output Return Loss		0.05		14.1		dB
		0.25		22.1		
		0.45		21.7		
		0.8		18.8		
		2.0		10.0		
		3.0		6.0		
Output Power @1 dB compression ⁽²⁾		0.05		22.4		dBm
		0.25		22.7		
		0.45		22.7		
		0.8		22.5		
		2.0		21.5		
		3.0		20.4		
Output IP3 ⁽⁶⁾		0.05	—	41.4		dBm
		0.25	—	41.4		
		0.45	—	41.6		
		0.8	37.0	41.5		
		2.0	—	42.9		
		3.0	—	41.8		
Noise Figure		0.05		1.8		dB
		0.25		1.8		
		0.45		1.8		
		0.8		1.8		
		2.0		2.2		
		3.0		2.7		
Matching between A1, A2	Amplitude Unbalance	0.05		0.11	—	dB
		0.25		0.12	—	
		0.45		0.12	—	
		0.8		0.12	0.6	
		2.0		0.22	—	
		3.0		0.25	—	
	Phase Unbalance	0.05		0.3	—	deg.
		0.25		0.31	—	
		0.45		0.51	—	
		0.8		1.0	5.0	
		2.0		1.6	—	
		3.0		2.0	—	
Device Operating Voltage			4.8	5.0	5.2	V
Device Operating Current (each amplifier)			110	146	180	mA
Device Current Variation vs. Temperature				23		μA/°C
Device Current Variation vs Voltage				0.053		mA/mV
Thermal Resistance, junction-to-ground lead ⁽⁷⁾				34		°C/W

MAXIMUM RATINGS⁽⁴⁾

Parameter	Ratings
Operating Temperature ⁽⁵⁾	-40°C to 85°C
Storage Temperature	-55°C to 150°C
Operating Current at 5V ⁽⁶⁾	200 mA
Power Dissipation ⁽⁶⁾	1000 mW
Input Power (CW)	+24 dBm
DC Voltage (pads 5,8)	6V

PUSH-PULL AMPLIFIER TYPICAL PERFORMANCE⁽³⁾

Freq. GHz	TB-566-75-11+ (75Ω)			TB-566-50-11+ (50Ω)			TB-666-50-11+ (50Ω)		
	Gain (dB)	Output IP3 (dBm)	Output IP2 (dBm)	Gain (dB)	Output IP3 (dBm)	Output IP2 (dBm)	Gain (dB)	Output IP3 (dBm)	Output IP2 (dBm)
0.05	14.2	45.0	79.0	15.2	45.0	82.0	14.1	40.1	71.4
0.25	13.7	43.0	79.0	13.8	45.0	84.0	13.8	40.7	70.5
0.45	14.0	42.0	81.0	13.8	44.0	81.0	14.1	42.2	75.6
0.85	14.1	43.0	72.0	13.0	44.0	76.0	13.1	40.4	71.5
1.20	13.8	40.6	78.0	12.0	43.0	72.0	12.9	39.4	62.1
1.30	13.5	40.3	78.0	--	--	--	12.8	40.0	56.8
1.50	--	--	--	--	--	--	12.2	39.7	60.8
2.00	--	--	--	--	--	--	11.8	41.0	65.2
3.00	--	--	--	--	--	--	8.6	36.2	70.8

(1) Measured on Mini-Circuits Test Board TB-561-11+ (characterization test circuit, Fig 1a.)

(2) Current increases at P1dB

(3) Measured on evaluation boards (push-pull amplifiers) TB-566-50-11+, TB-666-50-11+ (50Ω) and TB-566-75-11+ (75Ω) See Characterization Test Circuit (Fig. 1b)

(4) Permanent damage may occur if any of these limits are exceeded. These ratings are not intended for continuous normal operation.

(5) Defined with reference to ground pad temperature.

(6) Per single ended amplifier

(7) θ_{jc} = Junction Temperature-85°C. Voltage X sum of current in A1 & A2

Function	Pin Number	Description
RF IN, A1	1	RF input pin. This pin requires the use of an external DC blocking capacitor chosen for the frequency of operation. (see Application Circuit, Fig 2.)
RF-OUT and DC-IN, A1	8	RF output and bias pin. DC voltage is present on this pin; therefore a DC blocking capacitor is necessary for proper operation. An RF choke is needed to feed DC bias without loss of RF signal due to the bias connection, as shown in "Recommended Application Circuit", Fig 2
RF IN, A2	4	RF input pin. This pin requires the use of an external DC blocking capacitor chosen for the frequency of operation. (see Application Circuit, Fig 2.)
RF-OUT and DC-IN, A2	5	RF output and bias pin. DC voltage is present on this pin; therefore a DC blocking capacitor is necessary for proper operation. An RF choke is needed to feed DC bias without loss of RF signal due to the bias connection, as shown in "Recommended Application Circuit", Fig 2
GND	2,3,6,7 & paddle	Connections to ground. Use via holes as shown in "Suggested Layout for PCB Design" to reduce ground path inductance for best performance.

SIMPLIFIED SCHEMATIC (EACH OF A1, A2) AND PAD DESCRIPTION

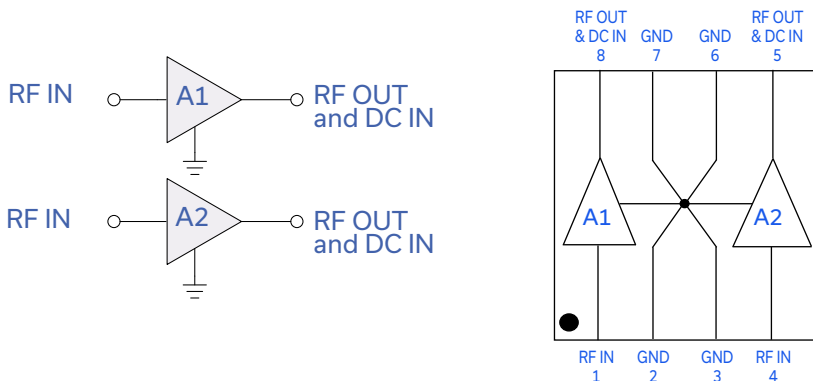



CHARACTERIZATION TEST CIRCUIT

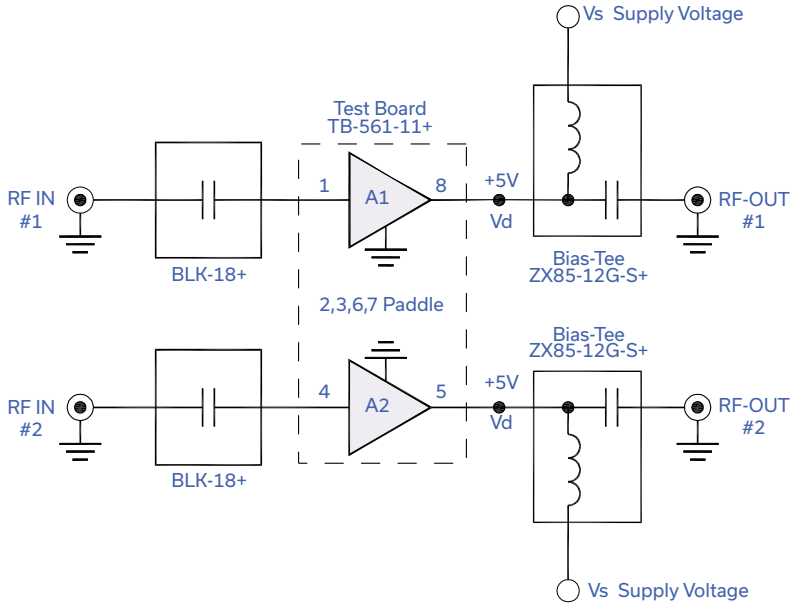

Fig 1a. Block Diagram of Test Circuit used for characterization. (DUT tested in Mini-Circuits Test board TB-561-11+, except for IP2) Gain, Return loss, Output power at 1dB compression (P1 dB) , output IP3 (OIP3) and noise figure measured using Agilent's N5242A PNA-X microwave network analyzer.

Conditions:

1. Gain and Return loss: Pin= -25dBm
2. Output IP3 (OIP3): Two tones, spaced 1MHz apart, 5 dBm/tone at output.

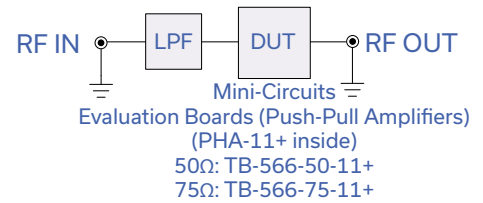

Fig 1b. Block Diagram of Test Set up used for characterization of Gain, IP2, IP3. Measured using Agilent's signal generators E8527D and Spectrum analyzer N9020A.

Conditions:

1. Two tones, spaced 1MHz apart, 5 dBm/tone at output. IP2 is measured at the sum frequency of the tones.

RECOMMENDED APPLICATION CIRCUIT

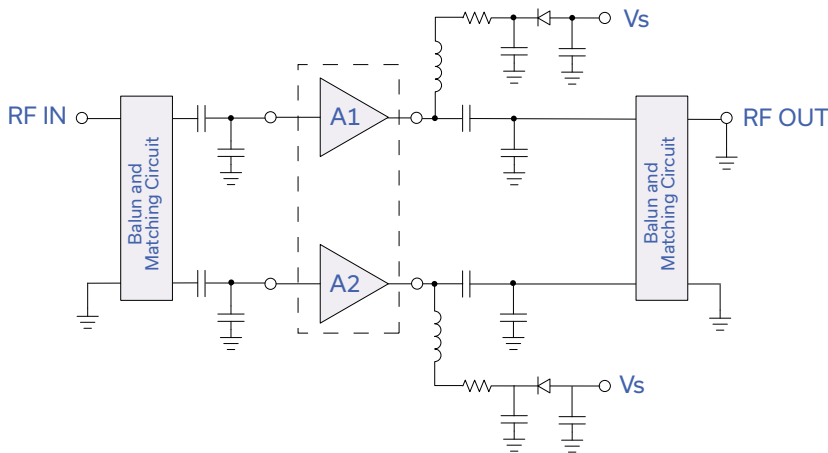
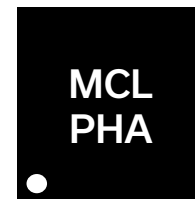

Fig 2. Recommended Application Circuit.
Refer to following Mini-Circuits Evaluation Boards for parts list.
50Ω: TB-566-50-11+
75Ω: TB-566-75-11+

PRODUCT MARKING



index over pin 1

Marking may contain other features or characters for internal lot control



SURFACE MOUNT DUAL MATCHED MMIC Amplifier

PHA-11+

ADDITIONAL DETAILED TECHNICAL INFORMATION IS AVAILABLE ON OUR DASH BOARD. TO ACCESS [CLICK HERE](#)

Performance Data	Data Table Swept Graphs S-Parameter (S2P Files) Data Set (.zip file)
Case Style	DL1020 Plastic package, exposed paddle lead finish: tin/silver/nickel
Tape & Reel Standard quantities available on reel	F68 7" reels with 20, 50, 100, 200, 500 or 1K devices 13" reels with 2K, 3K, 4K devices
Suggested Layout for PCB Design	PL-322
Evaluation Board	TB-566-50-11+ (50Ω, 0.05-1.2 GHz) TB-566-75-11+ (75Ω, 0.05-1.3 GHz) TB-666-50-11+ (50Ω, 0.05-3 GHz)
Environmental Ratings	ENV08T2

ESD RATING

Human Body Model (HBM): Class 1A (250 to <500V) in accordance with ANSI/ESD STM 5.1 - 2001
Machine Model (MM): Class M1 (<100V) in accordance with ANSI/ESD STM5.2-1999; passes 25V

MSL RATING

Moisture Sensitivity: MSL1 in accordance with IPC/JEDEC J-STD-020D

MSL TEST FLOW CHART

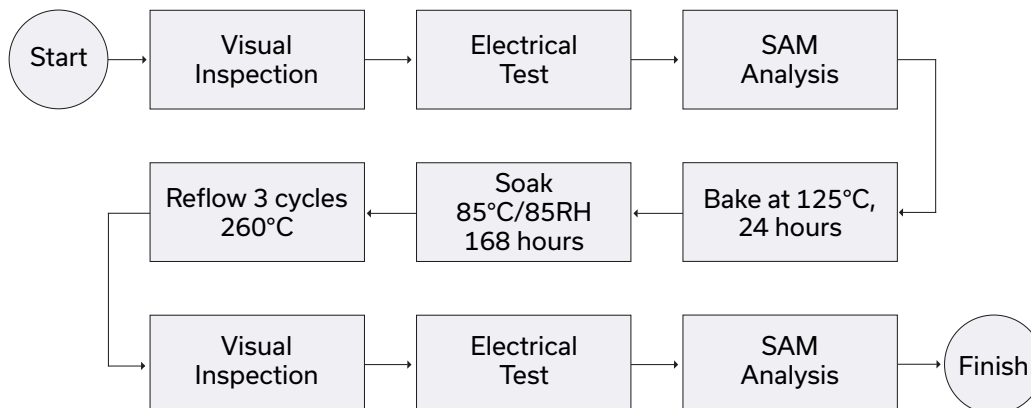

- NOTES**
- A. Performance and quality attributes and conditions not expressly stated in this specification document are intended to be excluded and do not form a part of this specification document.
 - B. Electrical specifications and performance data contained in this specification document are based on Mini-Circuit's applicable established test performance criteria and measurement instructions.
 - C. The parts covered by this specification document are subject to Mini-Circuits standard limited warranty and terms and conditions (collectively, "Standard Terms"); Purchasers of this part are entitled to the rights and benefits contained therein. For a full statement of the standard. Terms and the exclusive rights and remedies thereunder, please visit Mini-Circuits' website at www.minicircuits.com/MCLStore/terms.jsp



X-ON Electronics

Largest Supplier of Electrical and Electronic Components

Click to view similar products for [RF Amplifier](#) category:

Click to view products by [Mini-Circuits](#) manufacturer:

Other Similar products are found below :

[A82-1](#) [BGA622H6820XTSA1](#) [BGA 728L7 E6327](#) [BGB719N7ESDE6327XTMA1](#) [HMC397-SX](#) [HMC405](#) [HMC561-SX](#) [HMC8120-SX](#)
[HMC8121-SX](#) [HMC-ALH382-SX](#) [HMC-ALH476-SX](#) [SE2433T-R](#) [SMA3101-TL-E](#) [SMA39](#) [A66-1](#) [A66-3](#) [A67-1](#) [LX5535LQ](#) [LX5540LL](#)
[MAAM02350](#) [HMC3653LP3BETR](#) [HMC549MS8GETR](#) [HMC-ALH435-SX](#) [SMA101](#) [SMA32](#) [SMA411](#) [SMA531](#) [SST12LP17E-XX8E](#)
[SST12LP19E-QX6E](#) [WPM0510A](#) [HMC5929LS6TR](#) [HMC5879LS7TR](#) [HMC1126](#) [HMC1087F10](#) [HMC1086](#) [HMC1016](#) [SMA1212](#)
[MAX2689EWS+T](#) [MACS-007802-0M1RS0](#) [MAAMSS0041TR](#) [MAAM37000-A1G](#) [CHA5115-QDG](#) [SMA70-2](#) [SMA4011](#) [A231](#) [HMC-](#)
[AUH232](#) [LX5511LQ](#) [LX5511LQ-TR](#) [HMC7441-SX](#) [HMC-ALH310](#)