

# Ultra High Dynamic Range Monolithic Amplifier

## PHA-13HLN+

50Ω      1MHz to 1 GHz

### The Big Deal

- Ultra-High IP3, +43 dBm typ.
- Medium Power, +28.7dBm typ.
- Excellent Noise Figure, 1.1 dB typ.



SOT-89 PACKAGE

### Product Overview

PHA-13HLN+ (RoHS compliant) is an advanced wideband amplifier fabricated using E-PHEMT technology and offers extremely high dynamic range over a broad frequency range and with low noise figure. In addition, the PHA-13HLN+ has good input and output return loss over a broad frequency range. PHA-13HLN+ is enclosed in a SOT-89 package and has very good thermal performance.

### Key Features

Feature	Advantages
Broad Band: 1MHz to 1GHz	Broadband covering primary wireless communications bands: VHF, UHF, Cellular
Extremely High IP3 38.4 dBm typical at 1MHz 43 dBm typical at 0.5GHz	The PHA-13HLN+ matches industry leading IP3 performance relative to device size and power consumption. The combination of the design and E-PHEMT Structure provides enhanced linearity over a broad frequency range as evidence in the IP3 being approximately 15 dB above the P1dB point. This feature makes this amplifier ideal for use in: <ul style="list-style-type: none"><li>• Driver amplifiers for complex waveform up converter paths</li><li>• Drivers in linearized transmit systems</li><li>• Secondary amplifiers in ultra-High Dynamic range receivers</li></ul>
Low Noise Figure 1.1 dB at 0.5 GHz	Enables lower system noise figure performance
High P1dB 28.7 dBm at 500 MHz	High P1dB, High OIP3, Low NF results in a very dynamic range preventing amplifier saturation under strong interfering signals. It can also be used to drive mixers requiring high drive



# Ultra High Dynamic Range Monolithic Amplifier

1MHz to 1 GHz

## Product Features

- High IP3, 43 dBm typ. at 0.5GHz
- Gain, 22.7 dB typ. at 0.5 GHz
- High Pout, P1dB 28.7 dBm typ. at 0.5GHz
- Low noise figure, 1.1 dB at 0.5 GHz



Generic photo used for illustration purposes only

CASE STYLE: DF782

## PHA-13HLN+

**+RoHS Compliant**

The +Suffix identifies RoHS Compliance. See our web site for RoHS Compliance methodologies and qualifications

## Typical Applications

- Base station infrastructure
- CATV
- Cellular

## General Description

PHA-13HLN+ (RoHS compliant) is an advanced wideband amplifier fabricated using E-PHEMT technology and offers extremely high dynamic range over a broad frequency range and with low noise figure. In addition, the PHA-13HLN+ has good input and output return loss over a broad frequency range. PHA-13HLN+ is enclosed in a SOT-89 package and has very good thermal performance.

### simplified schematic and pin description

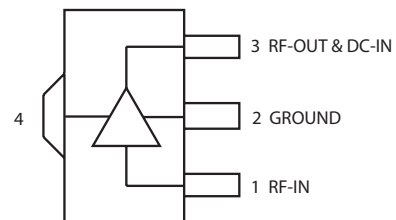
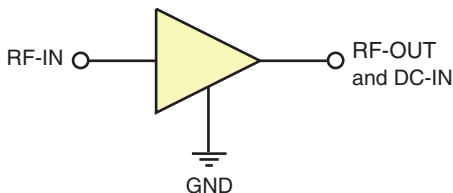

Function	Pin Number	Description
RF IN	1	RF Input
RF-OUT and DC-IN	3	RF Output and DC Bias
GND	2,4	Connections to ground.

**Electrical Specifications<sup>1</sup> at 25°C, 50Ω, unless noted**

Parameter	Condition (MHz)	Vd=8V <sup>1</sup>			Units
		Min.	Typ.	Max.	
Frequency Range		1		1000	MHz
Gain	1	22.4	25.0	27.4	dB
	20	—	24.3	—	
	250	—	23.0	—	
	500	20.4	22.7	25.0	
	1000	—	20.4	—	
Input Return Loss	1		10.8		dB
	20		15.8		
	250		16.7		
	500		17.5		
	1000		10.5		
Output Return Loss	1		11.2		dB
	20		18.8		
	250		17.7		
	500		29.4		
	1000		9.0		
Reverse isolation	500		26.3		dB
Output Power @1 dB compression	1		26.2		dBm
	20		27.3		
	250		28.4		
	500		28.7		
	1000		27.4		
Output IP3 <sup>2</sup>	1	—	38.4	—	dBm
	20	—	41.7	—	
	250	—	43.5	—	
	500	40.0	43.0	—	
	1000	—	42.2	—	
Noise Figure	1		3.0		dB
	20		1.2		
	250		1.1		
	500		1.1		
	1000		1.4		
Device Operating Voltage			8.0		V
Device Operating Current		—	234.1	251	mA
Device Current Variation vs. Temperature <sup>3</sup>			-100.6		μA/°C
Device Current Variation vs Voltage			0.0155		mA/mV
Thermal Resistance, junction-to-ground lead			23.3		°C/W
Junction-to-ground lead at 85°C stage temperature					

1. Measured on Mini-Circuits Characterization test board TB-969-13HLN+. See Characterization Test Circuit (Fig. 1)  
 2. Tested at Pout= 0 dBm / tone.  
 3. (Current at 85°C — Current at -45°C)/130

**Absolute Maximum Ratings<sup>4</sup>**

Parameter	Ratings
Operating Temperature (ground lead)	-40°C to 95°C
Storage Temperature	-65°C to 150°C
Power Dissipation	3.3 W <sup>5</sup>
Input Power (CW)	+21 dBm (5 minutes max) <sup>6</sup> +10 dBm (continuous) for 1-10 MHz +11 dBm (continuous) for 10-1000 MHz
DC Voltage on Pin 3	10V

4. Permanent damage may occur if any of these limits are exceeded.  
 Electrical maximum ratings are not intended for continuous normal operation.  
 5. up to 85°C, derate linearly to 2.5 W at 95°C.  
 6. up to 85°C, derate linearly to 18 dBm at 95°C.

Characterization Test / Recommended Application Circuit

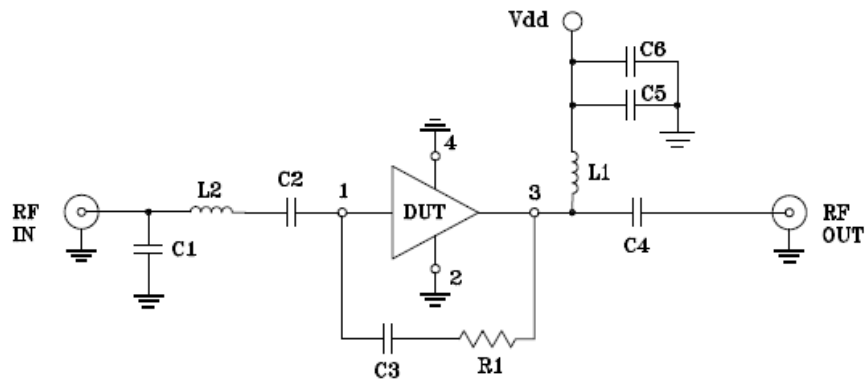

Components	Size	Value	Manufacturer	P/N
C1	0402	1.5 pF	Murata	GRM1555C1H1R5CZ01
C2	0603	2.2 uF		GRM188R61C225KE15
C3	0402	0.1uF		GRM155R71C104KA88
C4	0603	2.2 uF		GRM188R61C225KE15
C5	0402	1000 pF		GRM1555C1H102JA01
C6	0805	10 uF		GRM21BR61C106KE15
L1	1210	15 uH	Coilcraft	LQH32DN150K53L
L2	0603	5.1 nH	KoA	0603CS-5N1XJL
R1	0402	1500 Ω	KoA	RK73H1ET1501F

**Fig 1. Block Diagram of Test Circuit used for characterization.** (DUT soldered on Mini-Circuits Characterization test board TB-969-13HLN+) Gain, Return loss, Output power at 1dB compression (P1dB), output IP3 (OIP3) and noise figure measured using Agilent’s N5242A PNA-X microwave network analyzer.

**Conditions:**

1. Gain and Return loss: Pin= -25dBm
2. Output IP3 (OIP3): Two tones, spaced 0.5 MHz apart, 0 dBm/ tone at output.

**Product Marking**

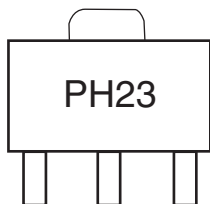

Marking may contain other features or characters for internal lot control

Additional Detailed Technical Information	
<i>additional information is available on our dash board. To access this information <a href="#">click here</a></i>	
<b>Performance Data</b>	Data Table
	Swept Graphs
	S-Parameter (S2P Files) Data Set (.zip file)
<b>Case Style</b>	DF782 (SOT 89) <i>Plastic package, exposed paddle lead finish: Matt-Tin</i>
<b>Tape &amp; Reel</b> Standard quantities available on reel	F55 <i>7" reels with 20, 50, 100, 200, 500 or 1K devices</i>
<b>Suggested Layout for PCB Design</b>	PL-523
<b>Evaluation Board</b>	TB-969-13HLN+
<b>Environmental Ratings</b>	ENV08T9

**ESD Rating**

Human Body Model (HBM): Class 1B (Pass 500 V) in accordance with ANSI/ESD STM 5.1 - 2001

**MSL Rating**

Moisture Sensitivity: MSL1 in accordance with IPC/JEDEC J-STD-020D

**MSL Test Flow Chart**

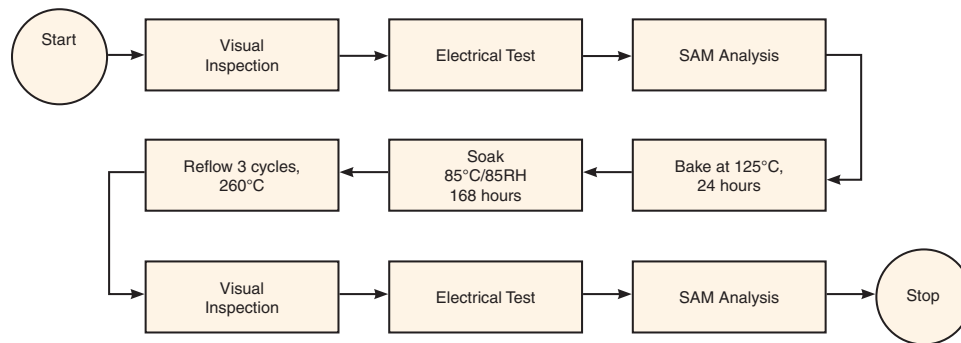

**Additional Notes**

- A. Performance and quality attributes and conditions not expressly stated in this specification document are intended to be excluded and do not form a part of this specification document.
- B. Electrical specifications and performance data contained in this specification document are based on Mini-Circuit's applicable established test performance criteria and measurement instructions.
- C. The parts covered by this specification document are subject to Mini-Circuits standard limited warranty and terms and conditions (collectively, "Standard Terms"); Purchasers of this part are entitled to the rights and benefits contained therein. For a full statement of the Standard Terms and the exclusive rights and remedies thereunder, please visit Mini-Circuits' website at [www.minicircuits.com/MCLStore/terms.jsp](http://www.minicircuits.com/MCLStore/terms.jsp)



## X-ON Electronics

Largest Supplier of Electrical and Electronic Components

*Click to view similar products for [RF Amplifier](#) category:*

*Click to view products by [Mini-Circuits](#) manufacturer:*

Other Similar products are found below :

[A82-1](#) [BGA622H6820XTSA1](#) [BGA 728L7 E6327](#) [BGB719N7ESDE6327XTMA1](#) [HMC397-SX](#) [HMC405](#) [HMC561-SX](#) [HMC8120-SX](#)  
[HMC8121-SX](#) [HMC-ALH382-SX](#) [HMC-ALH476-SX](#) [SE2433T-R](#) [SMA3101-TL-E](#) [SMA39](#) [A66-1](#) [A66-3](#) [A67-1](#) [LX5535LQ](#) [LX5540LL](#)  
[MAAM02350](#) [HMC3653LP3BETR](#) [HMC549MS8GETR](#) [HMC-ALH435-SX](#) [SMA101](#) [SMA32](#) [SMA411](#) [SMA531](#) [SST12LP17E-XX8E](#)  
[SST12LP19E-QX6E](#) [WPM0510A](#) [HMC5929LS6TR](#) [HMC5879LS7TR](#) [HMC1126](#) [HMC1087F10](#) [HMC1086](#) [HMC1016](#) [SMA1212](#)  
[MAX2689EWS+T](#) [MACS-007802-0M1RS0](#) [MAAMSS0041TR](#) [MAAM37000-A1G](#) [CHA5115-QDG](#) [SMA70-2](#) [SMA4011](#) [A231](#) [HMC-](#)  
[AUH232](#) [LX5511LQ](#) [LX5511LQ-TR](#) [HMC7441-SX](#) [HMC-ALH310](#)