



LOW NOISE, WIDEBAND, HIGH IP3

# Monolithic Amplifier PMA2-123LN+

50Ω 0.5 to 12 GHz

## THE BIG DEAL

- Ultra wideband, 0.5 to 12 GHz
- Flat gain over wideband, 17.6 dB with  $\pm 2.0$  dB
- Low noise figure, 2.6 dB at 8 GHz
- High IP3, up to +28 dBm

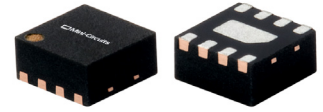

Generic photo used for illustration purposes only

CASE STYLE: MC1631-1

### +RoHS Compliant

The +Suffix identifies RoHS Compliance. See our web site for RoHS Compliance methodologies and qualifications

## APPLICATIONS

- WiFi
- WLAN
- UMTS
- LTE
- WiMAX
- S-band Radar
- C-band Satcom

## PRODUCT OVERVIEW

The PMA2-123LN+ is a PHEMT based wideband, low noise MMIC amplifier with a unique combination of low noise, high IP3, and flat gain over wideband making it ideal for sensitive, high-dynamic-range receiver applications. This design operates on a single 5V or 6V supply, is well matched for 50Ω and comes in a tiny, low profile package (2 x 2 mm, 8 lead MCLP), accommodating dense circuit board layouts.

## KEY FEATURES

Feature	Advantages
<b>Low noise</b> <ul style="list-style-type: none"> <li>• 2.2 dB at 2 GHz</li> <li>• 2.6 dB at 8 GHz</li> </ul>	Enables lower system noise figure performance.
<b>High IP3</b> <ul style="list-style-type: none"> <li>• +28 dBm at 2 GHz</li> <li>• +27 dBm at 8 GHz</li> </ul>	Combination of low noise and high IP3 makes this MMIC amplifier ideal for use in low noise receiver front end (RFE) as it gives the user advantages of sensitivity and two-tone IM performance at both ends of the dynamic range.
Low operating voltage, 5V/6V.	Achieves high IP3 using low voltage.
2 x 2mm 8-lead MCLP package	Tiny footprint saves space in dense layouts while providing low inductance, repeatable transitions, and excellent thermal contact to the PCB.
<b>Wide bandwidth with flat gain</b> <ul style="list-style-type: none"> <li>• <math>\pm 0.3</math> dB over 0.5 to 2 GHz</li> <li>• <math>\pm 0.7</math> dB over 0.5 to 6 GHz</li> <li>• <math>\pm 1.2</math> dB over 0.5 to 8 GHz</li> <li>• <math>\pm 2.0</math> dB over 0.5 to 12 GHz</li> </ul>	Enables usage in wideband applications flattering networks.





LOW NOISE, WIDEBAND, HIGH IP3

# Monolithic Amplifier **PMA2-123LN+**

## ELECTRICAL SPECIFICATIONS<sup>1</sup> AT 25°C, UNLESS NOTED OTHERWISE

Parameter	Condition (GHz)	V <sub>DD</sub> =6.0			V <sub>DD</sub> =5.0			Units
		Min.	Typ.	Max.	Min.	Typ.	Max.	
<b>Frequency Range</b>		0.5		12.0	0.5		12.0	GHz
<b>Noise Figure</b>	0.5		2.5			2.5		dB
	2.0		2.2			2.1		
	8.0		2.6			2.5		
	10.0		3.0			2.9		
	12.0		3.1			3.0		
<b>Gain</b>	0.5		18.6			17.7		dB
	2.0		19.2			18.3		
	8.0	15.2	16.8	18.5	14.5	16.1	17.8	
	10.0		16.1			15.4		
	12.0		15.3			14.7		
<b>Input Return Loss</b>	0.5		7.0			6.2		dB
	2.0		12.0			10.5		
	8.0		9.8			9.1		
	10.0		9.7			9.1		
	12.0		9.8			9.6		
<b>Output Return Loss</b>	0.5		11.4			9.6		dB
	2.0		14.5			12.4		
	8.0		22.0			19.4		
	10.0		16.5			15.9		
	12.0		9.6			8.9		
<b>Output Power at 1dB Compression<sup>2</sup></b>	0.5		15.2			13.9		dBm
	2.0		15.3			13.9		
	8.0		14.9			13.3		
	10.0		14.9			13.3		
	12.0		14.0			12.5		
<b>Output IP3</b>	0.5		27.4			24.9		dBm
	2.0		28.0			25.1		
	8.0		27.0			24.6		
	10.0		26.8			24.8		
	12.0		26.3			24.8		
<b>Device Operating Voltage (V<sub>DD</sub>)</b>			6.0			5.0		V
<b>Device Operating Current (I<sub>DD</sub>)</b>			68	82		51		mA
<b>Device Current Variation vs. Temperature<sup>3</sup></b>			-11.7			9.3		µA/°C
<b>Device Current Variation vs. Voltage</b>			0.0187			0.0184		mA/mV
<b>Thermal Resistance, junction-to-ground lead</b>			107			107		°C/W

1. Measured on Mini-Circuits Characterization Test Board TB-MB014. See Characterization Test Circuit (Fig. 1)

2. Current increases at P1dB up to 10mA typ. at 5Volts VDD

3. (Current at 85°C - Current at -45°C)/130

## MAXIMUM RATINGS<sup>4</sup>

Parameter	Ratings
<b>Operating Temperature (ground lead)</b>	-40°C to 85°C
<b>Storage Temperature</b>	-65°C to 150°C
<b>Junction Temperature</b>	160
<b>Total Power Dissipation</b>	0.7W
<b>Input Power (CW), Vd=5,6V<sup>5</sup></b>	+20 dBm (0.7 - 7.75 GHz) 5 minutes max. +22 dBm (7.75 - 15 GHz) 5 minutes max. +8 dBm (continuous)
<b>DC Voltage</b>	7V

4. Permanent damage may occur if any of these limits are exceeded. Electrical maximum ratings are not intended for continuous normal operation.

5. Measured on Mini-Circuits Test Board, TB-MB014





LOW NOISE, WIDEBAND, HIGH IP3

# Monolithic Amplifier PMA2-123LN+

## SIMPLIFIED SCHEMATIC & PAD DESCRIPTION

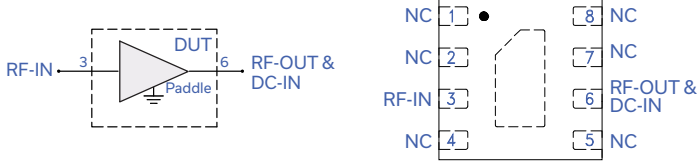

Function	Pad Number	Description (See Figure 2)
RF-IN	3	Connects to RF input via C1
RF-OUT & DC-IN	6	Connects to RF out and $V_{DD}$ via Bias-Tee
Ground	Paddle	Connects to ground
No Connection	1,2,4,5,7,8	Not used internally. Connected to ground on Test Board

## CHARACTERIZATION TEST CIRCUIT

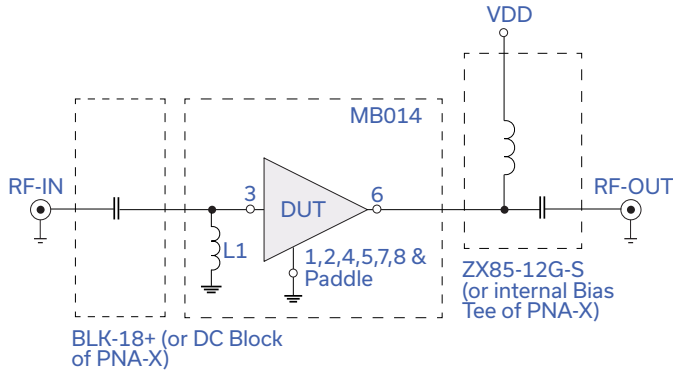

Fig 1. Application and Characterization Circuit

Note: This block diagram is used for characterization. (DUT soldered on Mini-Circuits Characterization test board TB-MB014+)

Gain, Return loss, Output power at 1dB compression (P1 dB), output IP3 (OIP3) and noise figure measured using Agilent's N5242A PNA-X microwave network analyzer.

Conditions:

1. Gain and Return loss: Pin= -25dBm
2. Output IP3 (OIP3): Two tones, spaced 1 MHz apart, 0 dBm/tone at output.

## RECOMMENDED APPLICATION CIRCUIT

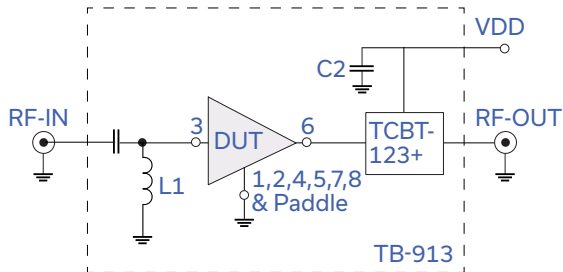
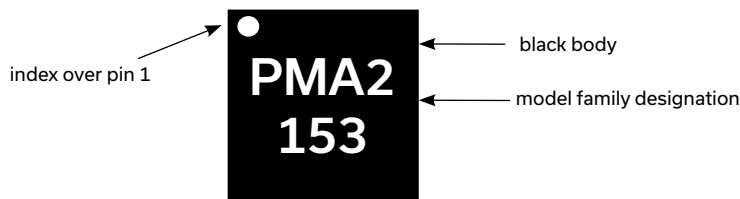

Fig 2. Test board (TB-913+) includes case, connectors and components soldered to PCB. (TB-913+ is a 3-layer PCB. See TB-913+ drawing.)

Component	Size	Value
L1	0402	20 nH
C1	0402	0.1 $\mu$ F
C2	0603	0.01 $\mu$ F

## PRODUCT MARKING



Marking may contain other features or characters for internal lot control





LOW NOISE, WIDEBAND, HIGH IP3

# Monolithic Amplifier PMA2-123LN+

Mini-Circuits

ADDITIONAL DETAILED TECHNICAL INFORMATION IS AVAILABLE ON OUR DASH BOARD. TO ACCESS [CLICK HERE](#)

<b>Performance Data</b>	<b>Data Table</b> <b>Swept Graphs</b> <b>S-Parameter (S2P Files) Data Set (.zip file)</b>
<b>Case Style</b>	<b>MC1631-1 Plastic package, exposed paddle, lead finish: tin silver over nickel</b>
<b>Tape &amp; Reel</b>	<b>F66</b>
<b>Standard quantities available on reel</b>	<b>7" reels with 20, 50, 100, 200, 500,1K or 2K devices</b>
<b>Suggested Layout for PCB Design</b>	<b>PL-490</b>
<b>Evaluation Board</b>	<b>TB-913+</b>
<b>Environmental Ratings</b>	<b>ENV08T1</b>

### ESD RATING

Human Body Model (HBM): Class 1A (250 to <500V) in accordance with ANSI/ESD STM 5.1 - 2001

### MSL RATING

Moisture Sensitivity: MSL1 in accordance with IPC/JEDEC J-STD-020D

### MSL TEST FLOW CHART

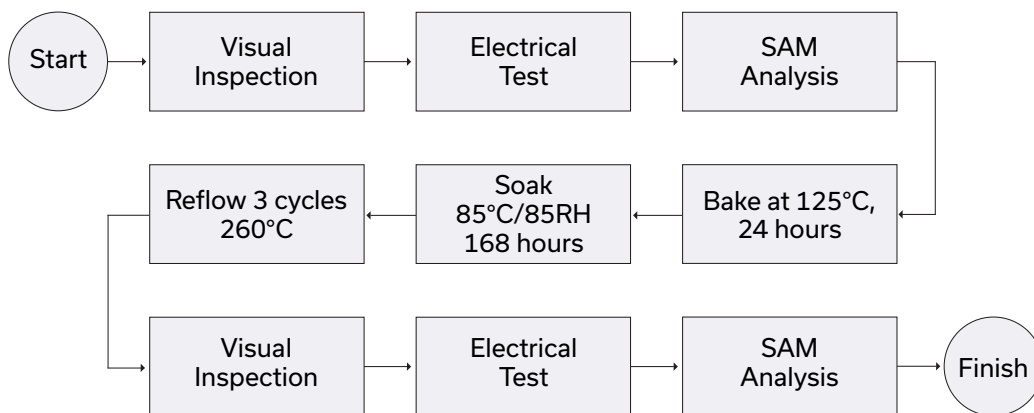

### NOTES

- A. Performance and quality attributes and conditions not expressly stated in this specification document are intended to be excluded and do not form a part of this specification document.
- B. Electrical specifications and performance data contained in this specification document are based on Mini-Circuit's applicable established test performance criteria and measurement instructions.
- C. The parts covered by this specification document are subject to Mini-Circuits standard limited warranty and terms and conditions (collectively, "Standard Terms"); Purchasers of this part are entitled to the rights and benefits contained therein. For a full statement of the standard. Terms and the exclusive rights and remedies thereunder, please visit Mini-Circuits' website at [www.minicircuits.com/MCLStore/terms.jsp](http://www.minicircuits.com/MCLStore/terms.jsp)



## X-ON Electronics

Largest Supplier of Electrical and Electronic Components

*Click to view similar products for [RF Amplifier](#) category:*

*Click to view products by [Mini-Circuits](#) manufacturer:*

Other Similar products are found below :

[A82-1](#) [BGA622H6820XTSA1](#) [BGA 728L7 E6327](#) [BGB719N7ESDE6327XTMA1](#) [HMC397-SX](#) [HMC405](#) [HMC561-SX](#) [HMC8120-SX](#)  
[HMC8121-SX](#) [HMC-ALH382-SX](#) [HMC-ALH476-SX](#) [SE2433T-R](#) [SMA3101-TL-E](#) [SMA39](#) [A66-1](#) [A66-3](#) [A67-1](#) [LX5535LQ](#) [LX5540LL](#)  
[MAAM02350](#) [HMC3653LP3BETR](#) [HMC549MS8GETR](#) [HMC-ALH435-SX](#) [SMA101](#) [SMA32](#) [SMA411](#) [SMA531](#) [SST12LP17E-XX8E](#)  
[SST12LP19E-QX6E](#) [WPM0510A](#) [HMC5929LS6TR](#) [HMC5879LS7TR](#) [HMC1126](#) [HMC1087F10](#) [HMC1086](#) [HMC1016](#) [SMA1212](#)  
[MAX2689EWS+T](#) [MACS-007802-0M1RS0](#) [MAAMSS0041TR](#) [MAAM37000-A1G](#) [CHA5115-QDG](#) [SMA70-2](#) [SMA4011](#) [A231](#) [HMC-](#)  
[AUH232](#) [LX5511LQ](#) [LX5511LQ-TR](#) [HMC7441-SX](#) [HMC-ALH310](#)