



LOW NOISE, WIDEBAND, HIGH IP3

Monolithic Amplifier

PMA3-83LN+

50Ω 0.5 to 8.0 GHz

THE BIG DEAL

- Flat gain over wideband
- Low noise figure, 1.3 dB at 2 GHz
- High IP3, up to +35 dBm at 2 GHz
- High Pout, P1dB 20.7 dBm at 2 GHz and 6V
- Suitable for low phase noise applications

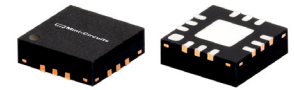

Generic photo used for illustration purposes only

CASE STYLE: DQ1225

+RoHS Compliant

The +Suffix identifies RoHS Compliance. See our web site for RoHS Compliance methodologies and qualifications

APPLICATIONS

- WiFi
- WLAN
- UMTS
- LTE
- WiMAX
- S-band Radar
- C-band Satcom

PRODUCT OVERVIEW

The PMA3-83LN+ is a PHEMT based wideband, low noise MMIC amplifier with a unique combination of low noise, high IP3, and flat gain over wideband making it ideal for sensitive, high-dynamic-range receiver applications. This design operates on a single 5V or 6V supply, is well matched for 50Ω and comes in a tiny, low profile package (3 x 3 x 0.89mm), accommodating dense circuit board layouts.

KEY FEATURES

Feature	Advantages
Low noise, 1.3 dB at 2 GHz	Enables lower system noise figure performance.
High IP3 <ul style="list-style-type: none"> • +35 dBm at 2 GHz • +28.5 dBm at 8 GHz 	Combination of low noise and high IP3 makes this MMIC amplifier ideal for use in low noise receiver front end (RFE) as it gives the user advantages of sensitivity and two-tone IM performance at both ends of the dynamic range.
Low operating voltage, 5V/6V.	Achieves high IP3 using low voltage.
3 x 3mm 12-lead MCLP package	Tiny footprint saves space in dense layouts while providing low inductance, repeatable transitions, and excellent thermal contact to the PCB.
Wide bandwidth with flat gain <ul style="list-style-type: none"> • ±0.9 dB over 0.5 to 7 GHz • ±1.5 dB over 0.5 to 8 GHz 	Enables a single amplifier to be used in many wideband applications including defense, instrumentation and more.
Low additive phase noise, typically <ul style="list-style-type: none"> • -155 dBc/Hz @10 KHz offset 	Ideal for low phase noise synthesizer applications

REV. D
ECO-010881
PMA3-83LN+
RS/CP
211201





LOW NOISE, WIDEBAND, HIGH IP3

Monolithic Amplifier

PMA3-83LN+

Mini-Circuits

ELECTRICAL SPECIFICATIONS¹ AT 25°C AND 5V, UNLESS NOTED

Parameter	Condition (GHz)	V _{DD} =6.0			V _{DD} =5.0			Units
		Min.	Typ.	Max.	Min.	Typ.	Max.	
Frequency Range		0.5		8.0	0.5		8.0	GHz
Noise Figure	0.5		1.8			1.9		dB
	2.0		1.3	1.7		1.3		
	4.0		1.5			1.5	1.9	
	5.0		1.5			1.6		
	8.0		2.2			2.2		
Additive Phase Noise	2.0 GHz, 10KHz offset		-155			-155		dBc/Hz
Gain	0.5		21.8			21.0		dB
	2.0	19.9	22.1	24.3		21.3		
	4.0		21.5			20.8		
	5.0		21.2		18.7	20.5		
	8.0		19.2			18.7		
Input Return Loss	0.5		14.2			13.1		dB
	2.0		16.0			16.0		
	4.0		13.0			12.2		
	5.0		12.5			12.4		
	8.0		6.3			6.3		
Output Return Loss	0.5		12.9			13.7		dB
	2.0		13.0			14.3		
	4.0		28.8			27.5		
	5.0		20.3			18.4		
	8.0		12.9			12.6		
Output Power at 1dB Compression ²	0.5		18.6			16.3		dBm
	2.0		20.7			19.1		
	4.0		19.6			17.6		
	5.0		20.3		17.2	18.9		
	8.0		18.0			17.3		
Output IP3	0.5		34.2			29.7		dBm
	2.0		35.2			30.0		
	4.0		34.0			29.6		
	5.0		34.0		24.0	29.7		
	8.0		28.5			26.2		
Device Operating Voltage (V _{DD})			6.0			5.0		V
Device Operating Current (I _{DD})			77	94		60		mA
Device Current Variation vs. Temperature ³			-152			-109		µA/°C
Device Current Variation vs. Voltage			0.016			0.016		mA/mV
Thermal Resistance, junction-to-ground lead			47			47		°C/W

1. Measured on Mini-Circuits Characterization test board TB-830A+. See Characterization Test Circuit (Fig. 1)

2. Current increases at P1dB to 109 mA typ. at +6V VDD and 88mA typ. at +5V VDD

3. (Current at 85°C - Current at -45°C)/130

MAXIMUM RATINGS⁴

Parameter	Ratings
Operating Temperature (ground lead)	-40°C to 105°C
Storage Temperature	-65°C to 150°C
Junction Temperature	150°C
Total Power Dissipation	0.95 W
Input Power (CW), V _d =5,6V ⁵	+19 dBm (5 minutes max.) +16 dBm (continuous)
DC Voltage	7 V

4. Permanent damage may occur if any of these limits are exceeded.

Electrical maximum ratings are not intended for continuous normal operation.

5. Measured on Mini-Circuits test board, TB-830A+





LOW NOISE, WIDEBAND, HIGH IP3

Monolithic Amplifier

PMA3-83LN+

SIMPLIFIED SCHEMATIC & PAD DESCRIPTION

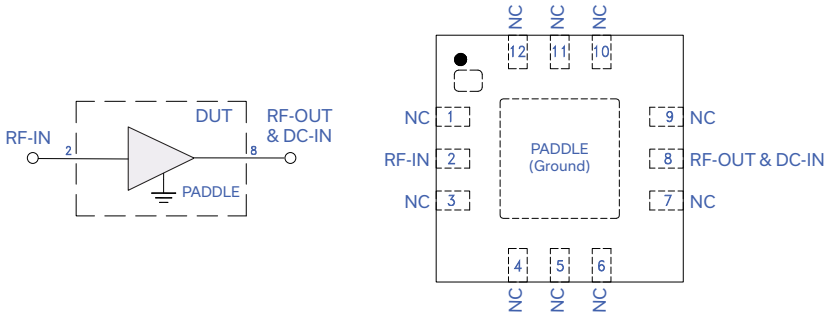

Function	Pad Number	Description (See Figure 1)
RF-IN	2	Connects to RF input and to ground via L1 (optional blocking capacitor of 100pF may be used)
RF-OUT & DC-IN	8	Connects to RF out via C3 and V_{DD} via L2
Ground	Paddle	Connects to ground
No Connection	1, 3 to 7, 9 to 12	Not used internally. Connected to ground on test board (except 11 and 12)

RECOMMENDED APPLICATION AND CHARACTERIZATION TEST CIRCUIT

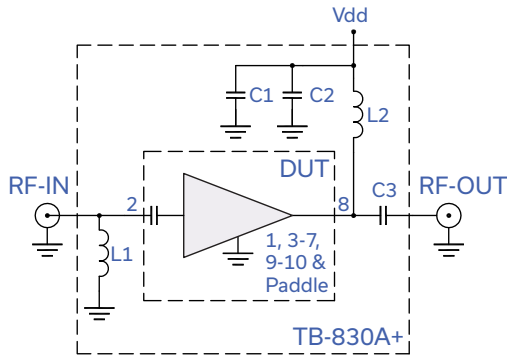

Fig 1. Application and Characterization Circuit

Note: This block diagram is used for characterization. (DUT soldered on Mini-Circuits Characterization test board TB-830A+)

Gain, Return loss, Output power at 1dB compression (P1 dB), output IP3 (OIP3) and noise figure measured using Agilent's N5242A PNA-X microwave network analyzer.

Conditions:

1. Gain and Return loss: Pin= -25dBm
2. Output IP3 (OIP3): Two tones, spaced 1 MHz apart, 0 dBm/tone at output.

Component	Vendor	Vendor P/N	Value	Size
C1	Murata	GRM155R71E103KA01D	0.01 μ F	0402
C2	Murata	GJM1555C1H100JB01D	10pF	0402
C3	Murata	GRM1555C1H101JA01D	100pF	0402
L1	Murata	LQG15HS18NJ02D	18nH	0402
L2	Coilcraft	0402CS-39NXGLW	39nH	0402

PRODUCT MARKING

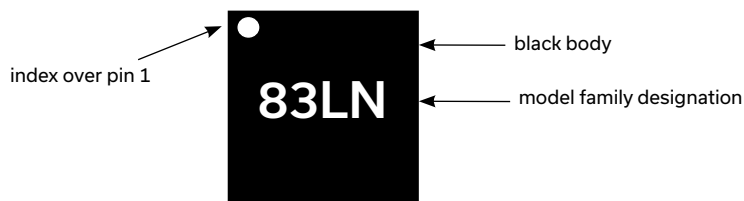

Marking may contain other features or characters for internal lot control





LOW NOISE, WIDEBAND, HIGH IP3

Monolithic Amplifier

PMA3-83LN+

ADDITIONAL DETAILED TECHNICAL INFORMATION IS AVAILABLE ON OUR DASH BOARD. TO ACCESS [CLICK HERE](#)

Performance Data	Data Table
	Swept Graphs
	S-Parameter (S2P Files) Data Set (.zip file)
Case Style	DQ1225 Plastic package, exposed paddle, lead finish: Matte-Tin
Tape & Reel	F66
Standard quantities available on reel	7" reels with 20, 50, 100, 200, 500,1K or 2K devices
Suggested Layout for PCB Design	PL-456
Evaluation Board	TB-830A+
Environmental Ratings	ENV08T1

ESD RATING

Human Body Model (HBM): Class 1A (250 to <500V) in accordance with ANSI/ESD STM 5.1 - 2001

Machine Model (MM): Class M1 (pass 50V) in accordance with ANSI/ESD STM5.2-1999

MSL RATING

Moisture Sensitivity: MSL1 in accordance with IPC/JEDEC J-STD-020D

MSL TEST FLOW CHART

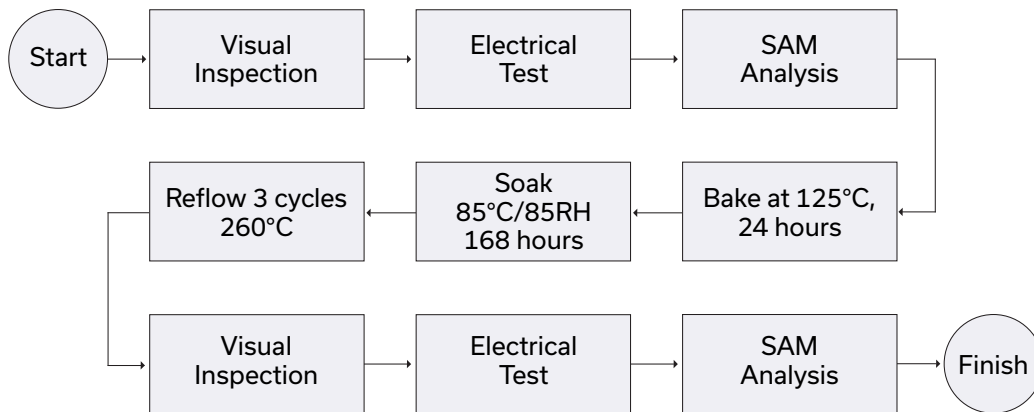

- NOTES**
- A. Performance and quality attributes and conditions not expressly stated in this specification document are intended to be excluded and do not form a part of this specification document.
 - B. Electrical specifications and performance data contained in this specification document are based on Mini-Circuit's applicable established test performance criteria and measurement instructions.
 - C. The parts covered by this specification document are subject to Mini-Circuits standard limited warranty and terms and conditions (collectively, "Standard Terms"); Purchasers of this part are entitled to the rights and benefits contained therein. For a full statement of the standard. Terms and the exclusive rights and remedies thereunder, please visit Mini-Circuits' website at www.minicircuits.com/MCLStore/terms.jsp



X-ON Electronics

Largest Supplier of Electrical and Electronic Components

Click to view similar products for [RF Amplifier](#) category:

Click to view products by [Mini-Circuits](#) manufacturer:

Other Similar products are found below :

[A82-1](#) [BGA622H6820XTSA1](#) [BGA 728L7 E6327](#) [BGB719N7ESDE6327XTMA1](#) [HMC397-SX](#) [HMC405](#) [HMC561-SX](#) [HMC8120-SX](#)
[HMC8121-SX](#) [HMC-ALH382-SX](#) [HMC-ALH476-SX](#) [SE2433T-R](#) [SMA3101-TL-E](#) [SMA39](#) [A66-1](#) [A66-3](#) [A67-1](#) [LX5535LQ](#) [LX5540LL](#)
[MAAM02350](#) [HMC3653LP3BETR](#) [HMC549MS8GETR](#) [HMC-ALH435-SX](#) [SMA101](#) [SMA32](#) [SMA411](#) [SMA531](#) [SST12LP17E-XX8E](#)
[SST12LP19E-QX6E](#) [WPM0510A](#) [HMC5929LS6TR](#) [HMC5879LS7TR](#) [HMC1126](#) [HMC1087F10](#) [HMC1086](#) [HMC1016](#) [SMA1212](#)
[MAX2689EWS+T](#) [MACS-007802-0M1RS0](#) [MAAMSS0041TR](#) [MAAM37000-A1G](#) [CHA5115-QDG](#) [SMA70-2](#) [SMA4011](#) [A231](#) [HMC-](#)
[AUH232](#) [LX5511LQ](#) [LX5511LQ-TR](#) [HMC7441-SX](#) [HMC-ALH310](#)