

## Silicon P-Channel Power MOSFET

### Description

The IRF5210 uses advanced technology and design to provide excellent  $R_{DS(on)}$ . It can be used in a wide variety of applications.

### General Features

- ①  $V_{DS}=-110V$ ,  $I_D=-35A$
- ② Low ON Resistance
- ③ Low Reverse transfer capacitances
- ④ 100% Single Pulse avalanche energy Test

### Application

- ① Power switching application
- ② Adapter and charger

### Electrical Characteristics

@  $T_a=25^\circ C$  (unless otherwise specified)

### Absolute Maximum Ratings:

Symbol	Parameter	Value	Units
$V_{DSS}$	Drain-to-Source Breakdown Voltage	-110	V
$I_D$	Drain Current (continuous) at $T_c=25^\circ C$	-35	A
$I_{DM}$	Drain Current (pulsed)	-120	A
$V_{GS}$	Gate to Source Voltage	+/-20	V
$P_{tot}$	Total Dissipation at $T_c=25^\circ C$	180	W
$T_j$	Max. Operating Junction Temperature	175	$^\circ C$
$E_{AS}$	Single Pulse Avalanche Energy	700	mJ

### Electrical Parameters:

Symbol	Parameter	Test Conditions	Min	Typ	Max	Unit
$V_{DS}$	Drain-source Voltage	$V_{GS}=0V$ , $I_D=-250\mu A$	-100			V
$R_{DS(on)}$	Static Drain-to-Source on-Resistance	$V_{GS}=-10V$ , $I_D=-15A$		26	32	$m\Omega$
$V_{GS(th)}$	Gated Threshold Voltage	$V_{DS}=V_{GS}$ , $I_D=-250\mu A$	-1.0	-2.0	-3.0	V
$I_{DSS}$	Drain to Source leakage Current	$V_{DS}=-110V$ , $V_{GS}=0V$			-1.0	$\mu A$

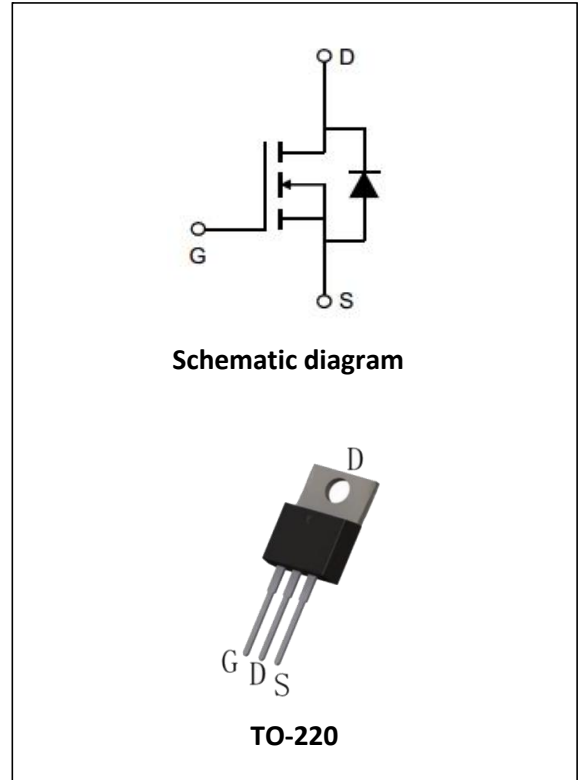

$I_{GSS(F)}$	Gated Body Forward Leakage	$V_{GS} = +20V$			100	nA
$I_{GSS(R)}$	Gated Body Reverse Leakage	$V_{GS} = -20V$			-100	nA
$C_{iss}$	Input Capacitance	$V_{GS} = 0V,$ $V_{DS} = 25V,$ $f = 1.0MHz$		2315		pF
$C_{oss}$	Output Capacitance			190		pF
$C_{rss}$	Reverse Transfer Capacitance			11		pF

**Switching Characteristics**

Symbol	Parameter	Test Conditions	Min	Typ	Max	Unit
$t_{d(on)}$	Turn-on Delay Time	$V_{DD} = -20V, I_D = -16A,$ $R_G = 10 \Omega$		28		nS
$t_r$	Turn-on Rise Time			21		nS
$t_{d(off)}$	Turn-off Delay Time			62		nS
$t_f$	Turn-off Fall Time			32		nS
$Q_g$	Total Gate Charge	$V_{DS} = -20V$ $I_D = -16A$ $V_{GS} = -10V$		40		nC
$Q_{gs}$	Gate-Source Charge			9.2		nC
$Q_{gd}$	Gate-Drain Charge			14		nC

**Source-Drain Diode Characteristics**

Symbol	Parameter	Test Conditions	Min	Typ	Max	Unit
$I_{SD}$	S-D Current(Body Diode)				-35	A
$I_{SDM}$	Pulsed S-D Current(Body Diode)				-140	A
$V_{SD}$	Diode Forward Voltage	$V_{GS} = 0V, I_{DS} = -35A$			-1.5	V
$t_{rr}$	Reverse Recovery Time	$T_J = 25^\circ C, I_F = -35A$ $di/dt = 100A/us$			555	nS
$Q_{rr}$	Reverse Recovery Charge				4550	$\mu C$
*Pulse Test: Pulse Width $\leq 300\mu s$ , Duty Cycle $\leq 2\%$						

Symbol	Parameter	Typ	Units
$R_{\theta JC}$	Junction-to-Case	2.5	$^\circ C/W$

Package Description

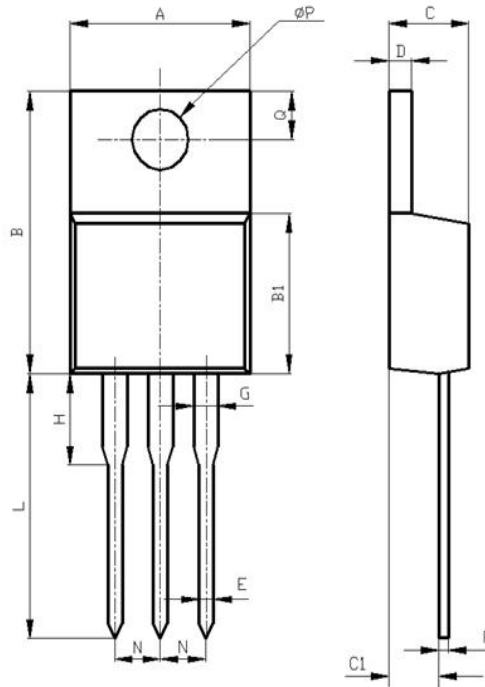

Items	Values(mm)	
	MIN	MAX
A	9.60	10.6
B	15.0	16.0
B1	8.90	9.50
C	4.30	4.80
C1	2.30	3.10
D	1.20	1.40
E	0.70	0.90
F	0.30	0.60
G	1.17	1.37
H	2.70	3.80
L	12.6	14.8
N	2.34	2.74
Q	2.40	3.00
φ P	3.50	3.90

TO-220 Package



**NOTE:**

1. Exceeding the maximum ratings of the device in performance may cause damage to the device, even the permanent failure, which may affect the dependability of the machine. Please do not exceed the absolute maximum ratings of the device when circuit designing.
2. When installing the heat sink, please pay attention to the torsional moment and the smoothness of the heat sink.
3. MOSFETs is the device which is sensitive to the static electricity, it is necessary to protect the device from being damaged by the static electricity when using it.
4. Shenzhen Minos reserves the right to make changes in this specification sheet and is subject to change without prior notice.

**CONTACT:**

**深圳市迈诺斯科技有限公司（总部）**

地址：深圳市福田区华富街道田面社区深南中路4026号田面城市大厦22B-22C

邮编：518025

电话：0755-83273777

## X-ON Electronics

Largest Supplier of Electrical and Electronic Components

*Click to view similar products for [MOSFET](#) category:*

*Click to view products by [Minos](#) manufacturer:*

Other Similar products are found below :

[IRFD120](#) [IRFY240C](#) [JANTX2N5237](#) [2SK2267\(Q\)](#) [BUK455-60A/B](#) [MIC4420CM-TR](#) [VN1206L](#) [NDP4060](#) [SI4482DY](#)  
[IPS70R2K0CEAKMA1](#) [SQD23N06-31L-GE3](#) [TK16J60W,S1VQ\(O](#) [2SK2614\(TE16L1,Q\)](#) [DMN1017UCP3-7](#) [EFC2J004NUZTDG](#)  
[DMN1053UCP4-7](#) [SQJ469EP-T1-GE3](#) [NTE2384](#) [DMC2700UDMQ-7](#) [DMN2080UCB4-7](#) [DMN61D9UWQ-13](#) [US6M2GTR](#)  
[DMN31D5UDJ-7](#) [DMP22D4UFO-7B](#) [DMN1006UCA6-7](#) [DMN16M9UCA6-7](#) [STF5N65M6](#) [IRF40H233XTMA1](#) [STU5N65M6](#)  
[DMN6022SSD-13](#) [DMN13M9UCA6-7](#) [DMTH10H4M6SPS-13](#) [DMN2990UFB-7B](#) [IPB80P04P405ATMA2](#) [2N7002W-G](#) [MCAC30N06Y-](#)  
[TP](#) [MCQ7328-TP](#) [NTMC083NP10M5L](#) [NVMFS2D3P04M8LT1G](#) [BXP7N65D](#) [BXP4N65F](#) [AOL1454G](#) [WMJ80N60C4](#) [BXP2N20L](#)  
[BXP2N65D](#) [BXT1150N10J](#) [BXT1700P06M](#) [TSM60NB380CP](#) [ROG](#) [RQ7L055BGTCR](#) [DMNH15H110SK3-13](#)