

60V N-Channel Power MOSFET

DESCRIPTION

The IRFZ44N uses advanced trench technology to provide excellent $R_{DS(ON)}$, low gate charge. It can be used in a wide variety of applications.

Application

- Power switching application
- Hard switched and High frequency circuits
- Uninterruptible power supply

KEY CHARACTERISTICS

- $V_{DS} = 60V, I_D = 60A$
 $R_{DS(ON)} < 15m\Omega @ V_{GS}=10V$
- High density cell design for lower R_{Dson}
- Fully characterized avalanche voltage and current
- Good stability and uniformity with high EAS
- Excellent package for good heat dissipation

100% UIS TESTED!
100% DVDS TESTED!



TO-220 Top View

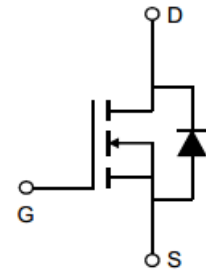

Schematic diagram

Package Marking And Ordering Information

| Device Marking | Ordering Codes | Package | Product Code | Packing |
|----------------|----------------|---------|--------------|---------|
| IRFZ44N | IRFZ44N | TO-220 | IRFZ44N | Tube |

Absolute Maximum Ratings ($T_A=25^\circ C$ unless otherwise noted)

| Parameter | Symbol | Limit | Unit |
|--|----------------|------------|------------|
| Drain-Source Voltage | V_{DS} | 60 | V |
| Gate-Source Voltage | V_{GS} | ± 20 | V |
| Drain Current-Continuous | I_D | 60 | A |
| Drain Current-Pulsed (Note 1) | I_{DM} | 200 | A |
| Maximum Power Dissipation ($T_c=25^\circ C$) | P_D | 87 | W |
| Single pulse avalanche energy (Note 2) | E_{AS} | 120 | mJ |
| Operating Junction and Storage Temperature Range | T_J, T_{STG} | -55 To 175 | $^\circ C$ |

Thermal Characteristic

| | | | |
|--------------------------------------|-----------------|------|-----------------------------|
| Thermal Resistance, Junction-to-Case | $R_{\theta JC}$ | 1.72 | $^{\circ}\text{C}/\text{W}$ |
|--------------------------------------|-----------------|------|-----------------------------|

Electrical Characteristics (TA=25°C unless otherwise noted)

| Parameter | Symbol | Condition | Min | Typ | Max | Unit |
|--|--------------|---|-----|-----|-----------|------------|
| Off Characteristics | | | | | | |
| Drain-Source Breakdown Voltage | BV_{DSS} | $V_{GS}=0V, I_D=250\mu A$ | 60 | - | - | V |
| Zero Gate Voltage Drain Current | I_{DSS} | $V_{DS}=60V, V_{GS}=0V$ | - | - | 1 | μA |
| Gate-Body Leakage Current | I_{GSS} | $V_{GS}=\pm 20V, V_{DS}=0V$ | - | - | ± 100 | nA |
| On Characteristics | | | | | | |
| Gate Threshold Voltage | $V_{GS(th)}$ | $V_{DS}=V_{GS}, I_D=250\mu A$ | 2 | 3 | 4 | V |
| Drain-Source On-State Resistance ^(Note 3) | $R_{DS(on)}$ | $V_{GS}=10V, I_D=25A$ | - | 12 | 15 | m Ω |
| Forward Transconductance | g_{FS} | $V_{DS}=25V, I_D=25A$ | - | 25 | - | S |
| Dynamic Characteristics | | | | | | |
| Input Capacitance | C_{iss} | $V_{DS}=25V, V_{GS}=0V,$ $f=1.0\text{MHz}$ | - | 910 | - | pF |
| Output Capacitance | C_{oss} | | - | 100 | - | pF |
| Reverse Transfer Capacitance | C_{rss} | | - | 30 | - | pF |
| Switching Characteristics ^(Note 4) | | | | | | |
| Turn-on Delay Time | $t_{d(on)}$ | $V_{DD}=30V, I_D=20A,$ $V_{GS}=10V, R_{GEN}=5\Omega$ | - | 26 | - | nS |
| Turn-on Rise Time | t_r | | - | 6 | - | nS |
| Turn-Off Delay Time | $t_{d(off)}$ | | - | 52 | - | nS |
| Turn-Off Fall Time | t_f | | - | 7 | - | nS |
| Total Gate Charge | Q_g | $V_{DS}=30V, I_D=50A$ $V_{GS}=10V$ | - | 31 | - | nC |
| Gate-Source Charge | Q_{gs} | | - | 9 | - | nC |
| Gate-Drain Charge | Q_{gd} | | - | 5 | - | nC |
| Drain-Source Diode Characteristics | | | | | | |
| Diode Forward Voltage | V_{SD} | $V_{GS}=0V, I_S=50A$ | - | - | 1.2 | V |

Notes:

1. Repetitive Rating: Pulse width limited by maximum junction temperature.
2. EAS condition : $T_j=25^{\circ}\text{C}, V_{DD}=30V, V_{GS}=10V, L=0.5\text{mH}, R_g=25\Omega$
3. Pulse Test: Pulse Width $\leq 300\mu\text{s}$, Duty Cycle $\leq 2\%$.
4. Guaranteed by design, not subject to production.

Characteristics Curves

Figure 1 Output Characteristics

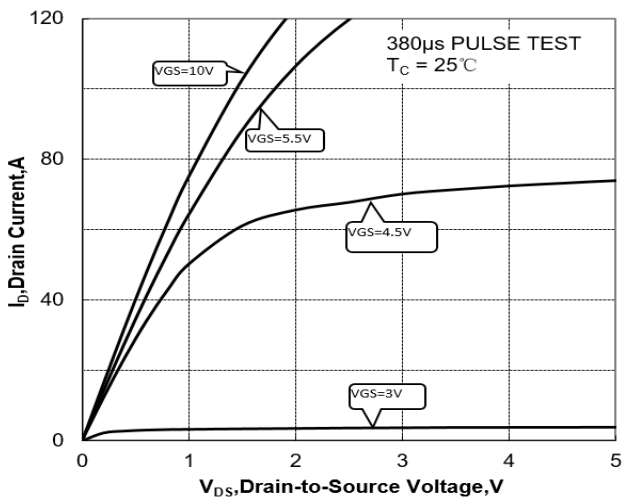

Figure 2 Transfer Characteristics

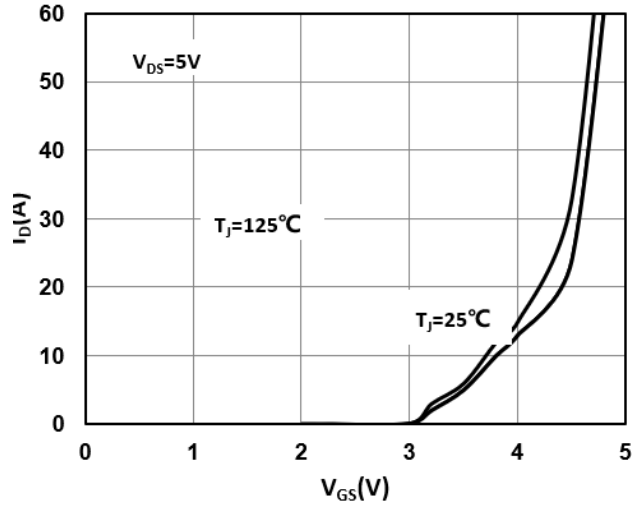

Figure 3 On-Resistance vs. I_D and V_{GS}

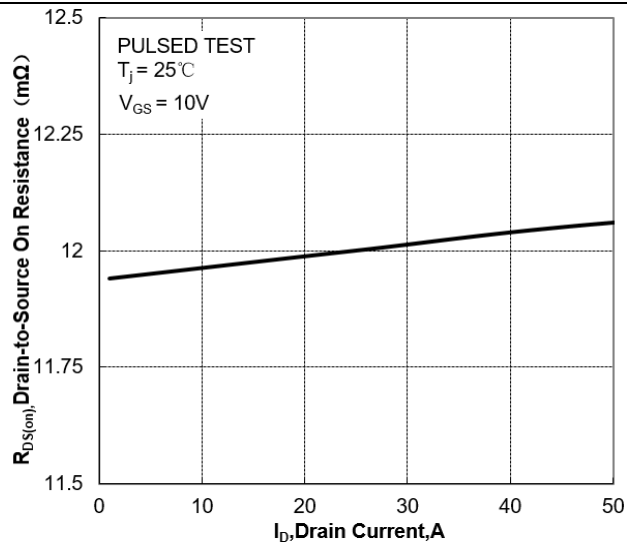

Figure 4 On-Resistance vs. Junction Temperature

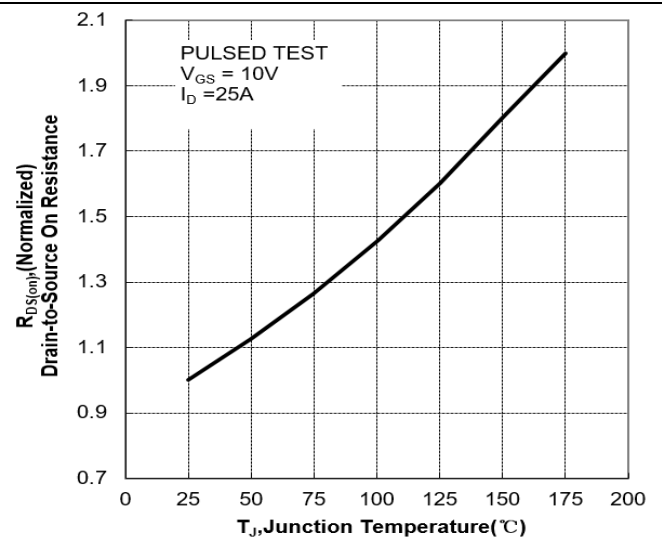

Figure 5 On-Resistance vs. V_{GS}

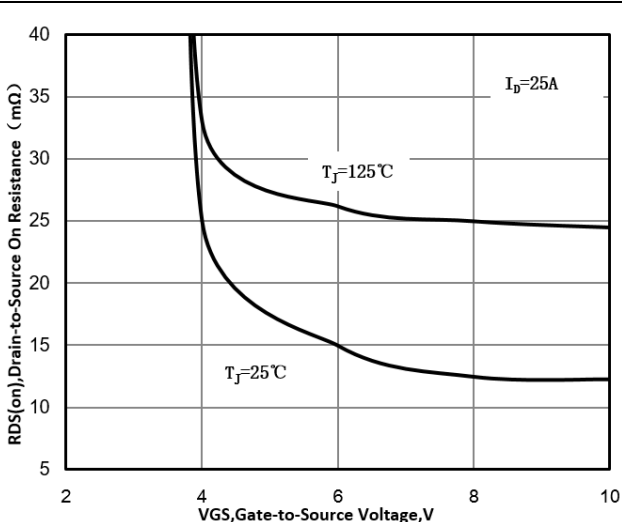

Figure 6 Body Diode Forward Voltage

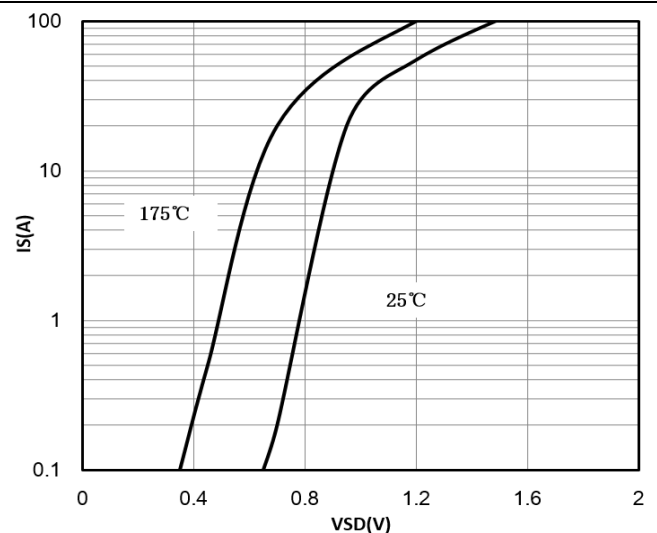

Figure 7 Gate-Charge Characteristics

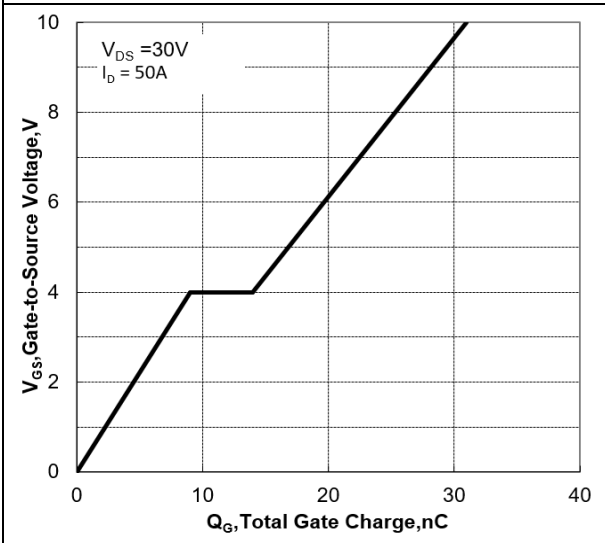

Figure 8 Capacitance Characteristics

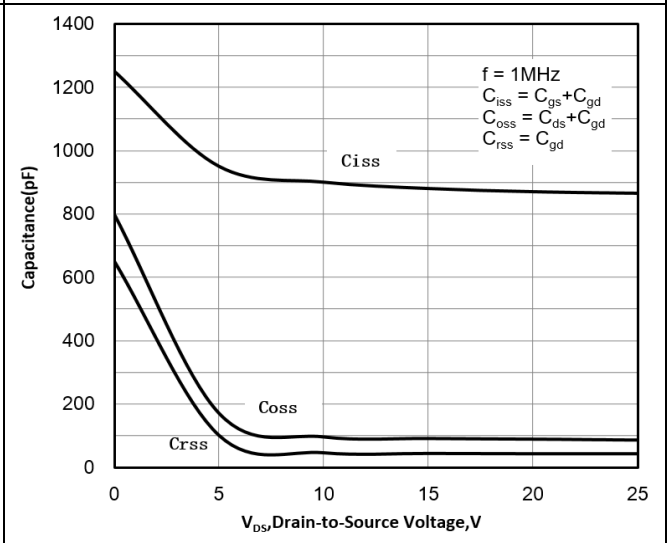

Figure 9 Maximum Forward Biased Safe Operation Area

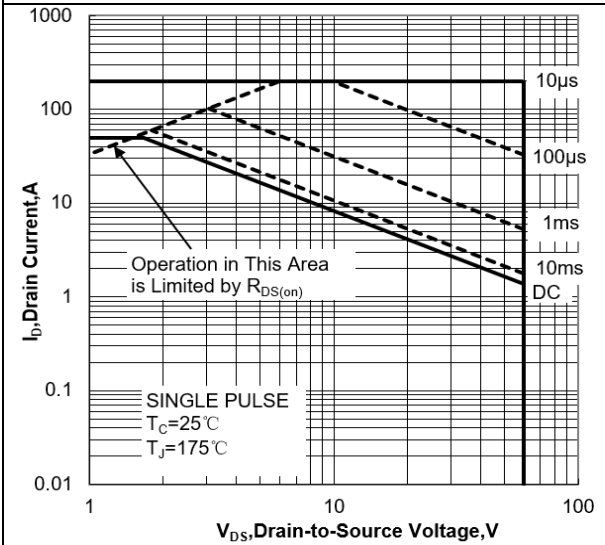

Figure 10 Single Pulse Power Rating Junction-to-Ambient

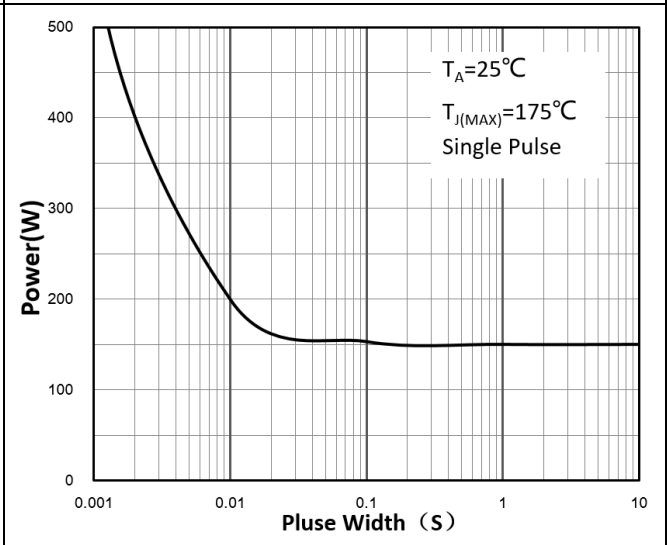
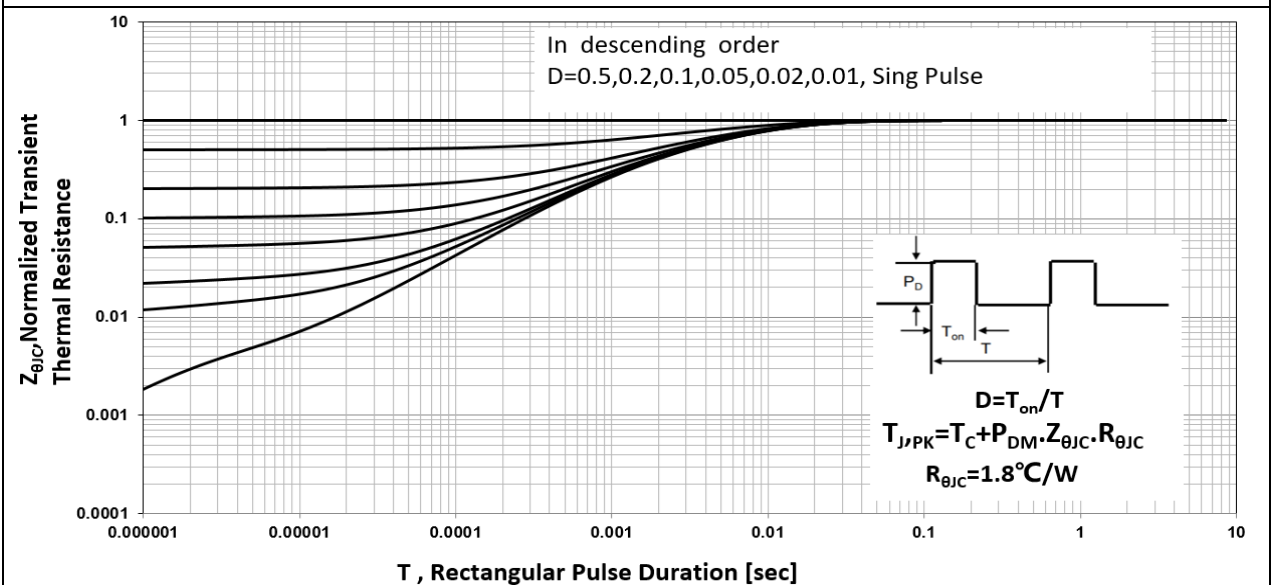
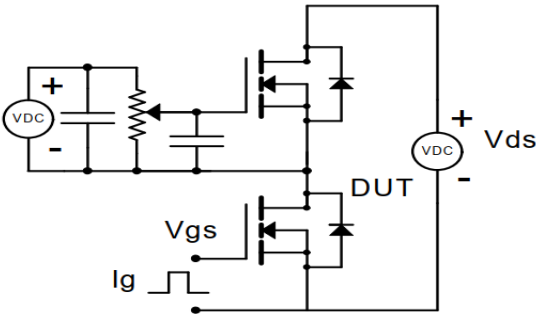
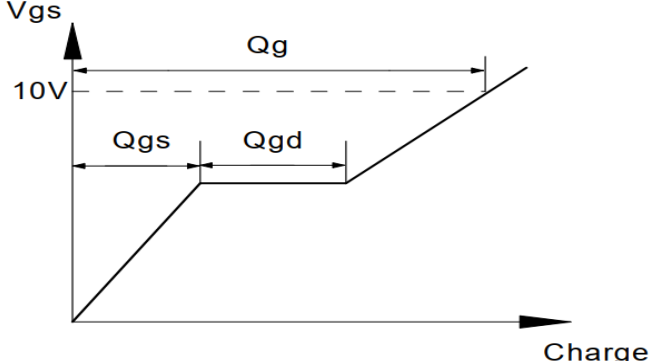
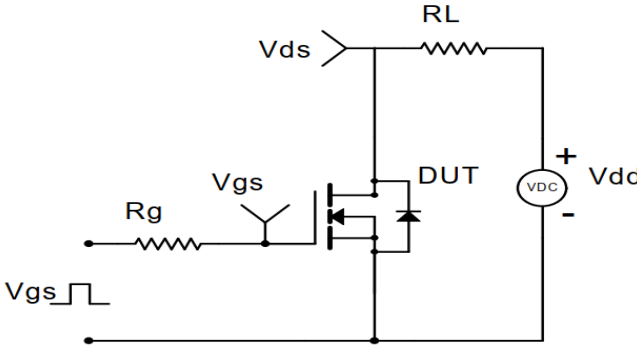
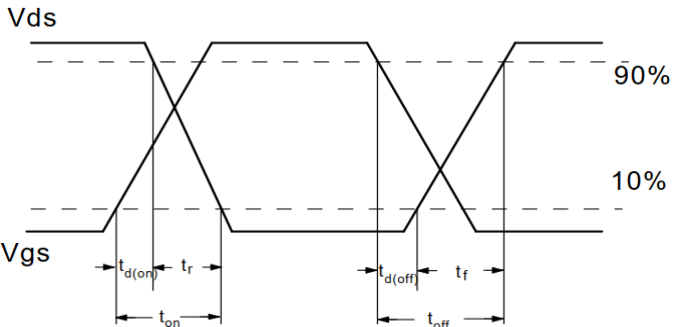
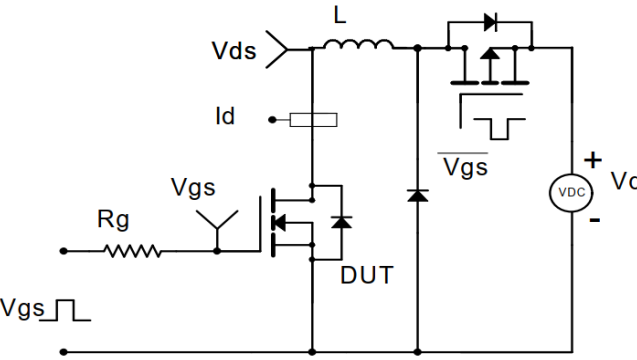
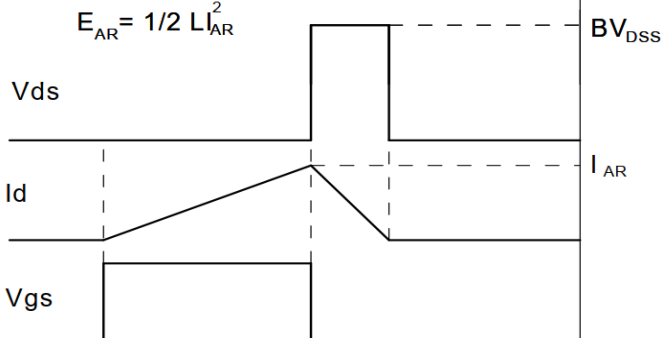
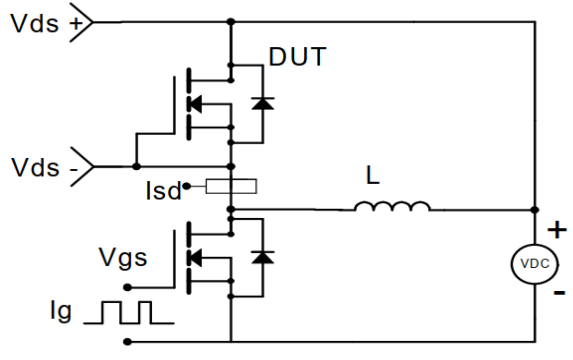
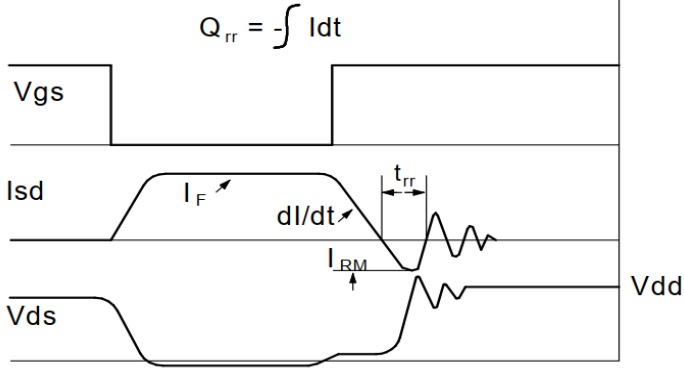

Figure 11 Normalized Maximum Transient Thermal Impedance



Test Circuit and Waveform

| | |
|--|---|
| <p>Gate Charge Test Circuit</p>  | <p>Gate Charge Test Waveform</p>  |
| <p>Resistive Switching Test Circuit</p>  | <p>Resistive Switching Test Waveforms</p>  |
| <p>Unclamped Inductive Switching (UIS) Test Circuit</p>  | <p>Unclamped Inductive Switching (UIS) Test Waveforms</p>  |
| <p>Diode Recovery Test Circuit</p>  | <p>Diode Recovery Test Waveforms</p>  |

Package Description

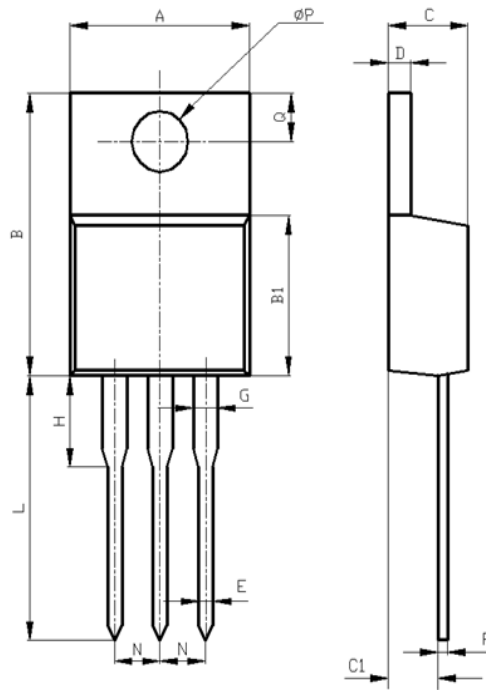

| Items | Values(mm) | |
|-------|------------|------|
| | MIN | MAX |
| A | 9.60 | 10.6 |
| B | 15.0 | 16.0 |
| B1 | 8.90 | 9.50 |
| C | 4.30 | 4.80 |
| C1 | 2.30 | 3.10 |
| D | 1.20 | 1.40 |
| E | 0.70 | 0.90 |
| F | 0.30 | 0.60 |
| G | 1.17 | 1.37 |
| H | 2.70 | 3.80 |
| L | 12.6 | 14.8 |
| N | 2.34 | 2.74 |
| Q | 2.40 | 3.00 |
| φ P | 3.50 | 3.90 |

TO-220 Package

NOTE:

1. Exceeding the maximum ratings of the device in performance may cause damage to the device, even the permanent failure, which may affect the dependability of the machine. Please do not exceed the absolute maximum ratings of the device when circuit designing.
2. When installing the heat sink, please pay attention to the torsional moment and the smoothness of the heat sink.
3. MOSFETs is the device which is sensitive to the static electricity, it is necessary to protect the device from being damaged by the static electricity when using it.
4. Shenzhen Minos reserves the right to make changes in this specification sheet and is subject to change without prior notice.

CONTACT:

深圳市迈诺斯科技有限公司 (总部)

地址：深圳市福田区华富街道田面社区深南中路4026号田面城市大厦22B-22C

电话：0755—83273777

X-ON Electronics

Largest Supplier of Electrical and Electronic Components

Click to view similar products for [MOSFET](#) category:

Click to view products by [Minos](#) manufacturer:

Other Similar products are found below :

[IRFD120](#) [IRFY240C](#) [JANTX2N5237](#) [2SK2267\(Q\)](#) [BUK455-60A/B](#) [MIC4420CM-TR](#) [VN1206L](#) [NDP4060](#) [SI4482DY](#)
[IPS70R2K0CEAKMA1](#) [SQD23N06-31L-GE3](#) [TK16J60W,S1VQ\(O](#) [2SK2614\(TE16L1,Q\)](#) [DMN1017UCP3-7](#) [EFC2J004NUZTDG](#)
[DMN1053UCP4-7](#) [SQJ469EP-T1-GE3](#) [NTE2384](#) [DMC2700UDMQ-7](#) [DMN2080UCB4-7](#) [DMN61D9UWQ-13](#) [US6M2GTR](#)
[DMN31D5UDJ-7](#) [DMP22D4UFO-7B](#) [DMN1006UCA6-7](#) [DMN16M9UCA6-7](#) [STF5N65M6](#) [IRF40H233XTMA1](#) [STU5N65M6](#)
[DMN6022SSD-13](#) [DMN13M9UCA6-7](#) [DMTH10H4M6SPS-13](#) [DMN2990UFB-7B](#) [IPB80P04P405ATMA2](#) [2N7002W-G](#) [MCAC30N06Y-](#)
[TP](#) [MCQ7328-TP](#) [NTMC083NP10M5L](#) [NVMFS2D3P04M8LT1G](#) [BXP7N65D](#) [BXP4N65F](#) [AOL1454G](#) [WMJ80N60C4](#) [BXP2N20L](#)
[BXP2N65D](#) [BXT1150N10J](#) [BXT1700P06M](#) [TSM60NB380CP](#) [ROG](#) [RQ7L055BGTCR](#) [DMNH15H110SK3-13](#)