

■ 概述

LM317T 为可调节 3 端正电压稳压器，在输出电压范围为 1.2V 到 37V 时能够提供超过 1.5A 的电流。该电路内置有内部限流、热关断、安全工作区补偿等。

■ 主要特点

输出电流超过 1.5A 输出在 1.2V 和 37V 之间可调节内部热过载保护不随温度变化的内部短路电流限制输出晶体管 SOA 补偿压应用浮空工作

■ 极限值 (Ta=25°C)

$V_i - V_o$	— 输入输出电压差	40V
T_{OPR}	— 工作结温范围	0~125°C
T_{STG}	— 贮存温度范围	-65~150 °C
P_D	— 功耗	内部限制 W
$R_{\theta JC}$	— 热阻 (结到壳)	5°C/W
$R_{\theta JA}$	— 热阻 (结到环境)	80°C/W

■ 外形图及引脚排列

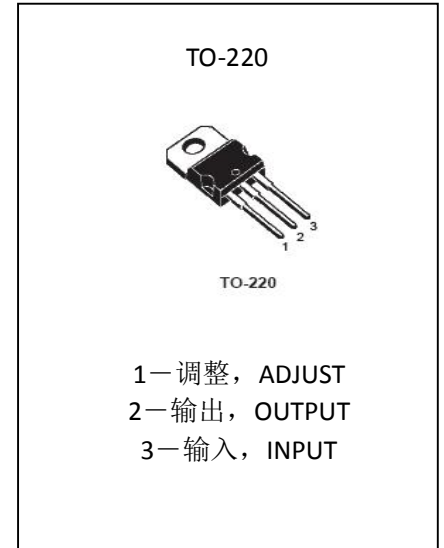

■ 功能框图

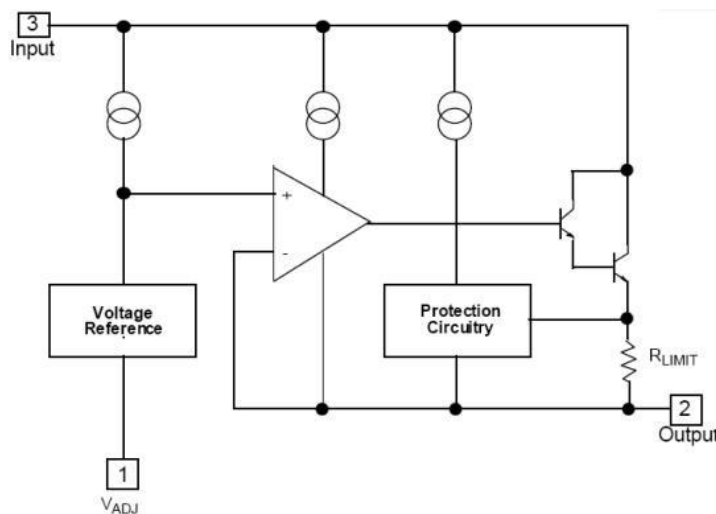

Figure 1. Block Diagram

电参数

($V_I - V_O = 5V$, $I_O = 500mA$, $0^\circ C \leq T_J \leq 125^\circ C$, $I_{MAX} = 1.5A$, $P_{MAX} = 20W$, 除非另有规定)

参数符号	符号说明	最小值	典型值	最大值	单位	测试条件
R_{LINE}	电源调整率 (注1)		0.01	0.04	% / V	$T_A = 25^\circ C$, $3V \leq V_I - V_O \leq 40V$
			0.02	0.07		$3V \leq V_I - V_O \leq 40V$
R_{LOAD}	负载调整率 (注1)		18	25	mV	$T_A = 25^\circ C$, $V_O < 5V$
			0.4	0.5	% / V_O	$10mA \leq I_O \leq I_{MAX}$, $V_O \geq 5V$
			40	70	mV	$10mA \leq I_O \leq I_{MAX}$, $V_O < 5V$
			0.8	1.5	% / V_O	$V_O \geq 5V$
I_{ADJ}	调整脚电流		46	100	μA	
ΔI_{ADJ}	调整脚电流变化		2.0	5.0	μA	$3V \leq V_I - V_O \leq 40V$, $10mA \leq I_O \leq I_{MAX}$, $P_D \leq P_{MAX}$
V_{REF}	参考电压	1.2	1.25	1.3	V	$3V \leq V_I - V_O \leq 40V$, $10mA \leq I_O \leq I_{MAX}$, $P_D \leq P_{MAX}$
TS	温度稳定性		0.7		% / V_O	
$I_{L(MIN)}$	最小负载电流以保持调整率		5	12	mA	$V_I - V_O = 40V$
$I_{O(MAX)}$	最大输出电流	1.5	2.2			$T_A = 25^\circ C$, $V_I - V_O \leq 15V$, $P_D \leq P_{MAX}$
			0.3		A	$T_A = 25^\circ C$, $V_I - V_O \leq 40V$, $P_D \leq P_{MAX}$
N	RMS噪声, % of V_{OUT}		0.003	0.01	% / V	$T_A = 25^\circ C$, $10Hz \leq f \leq 10kHz$
RR	纹波抑制比		60			$f = 120Hz$, $V_O = 10V$, 无 C_{ADJ}
		66	75		dB	$C_{ADJ} = 10 \mu F$ (注2)
ST	长期稳定性 $T_J = T_{HIGH}$		0.3	1	%	$T_A = 25^\circ C$, 1000HR, 终点测量时

注:

1、电源和负载调整率在恒定结温时规定。热效应引起的 V_O 变化必须分别考虑。使用低占空比的脉冲测试 ($P_{MAX} = 20W$)

Load and line regulation are specified at constant junction temperature. Change in V_O due to heating effects must be taken into account separately. Pulse testing with low duty is used ($P_{MAX} = 20 W$).

2、使用 C_{ADJ} 时应连接在调整管脚和地之间。

C_{ADJ} , when used, is connected between the adjustment pin and ground

■ 典型特性曲线



图 2. 负载调整率
Figure 2. Load Regulation



图 3. 电流限制
Figure 3. Current Limit

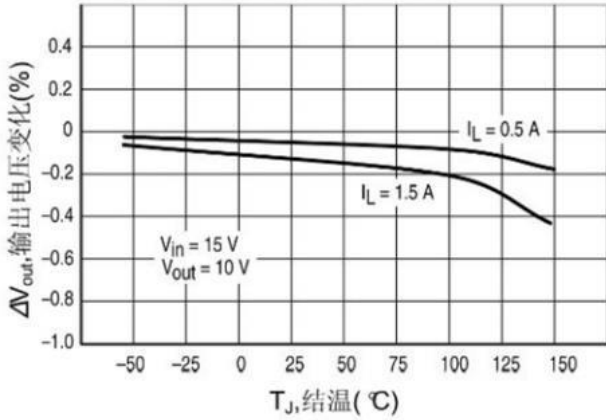

图 4. 调整管脚电流
Figure 4. Adjustment Current

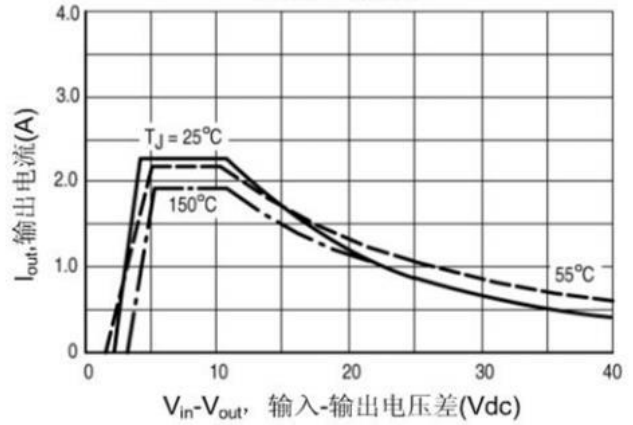

图 5. 电压压降
Figure 5. Dropout Voltage

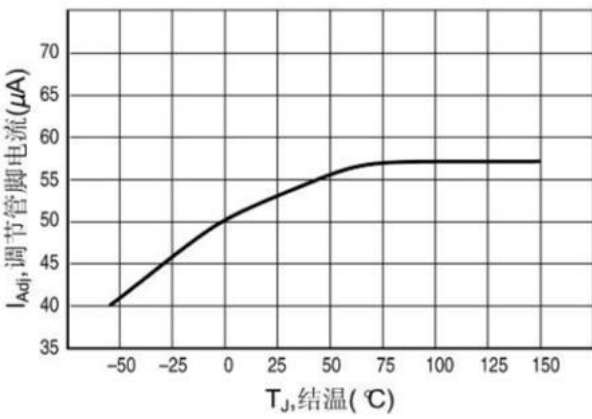

图 6. 参考电压
Figure 6. Reference Voltage

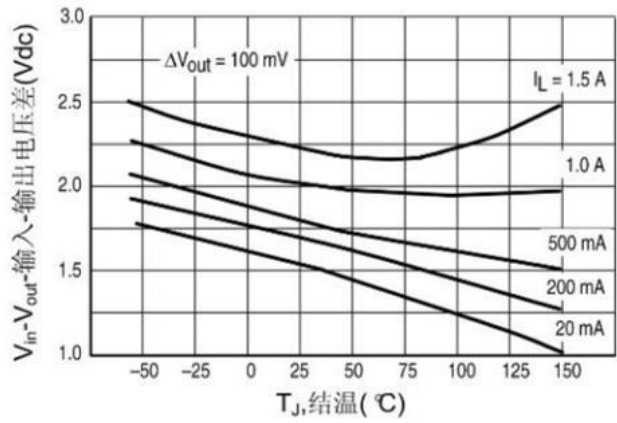

图 7. 最小工作电流
Figure 7. Minimum Operating Current

■ 典型应用电路

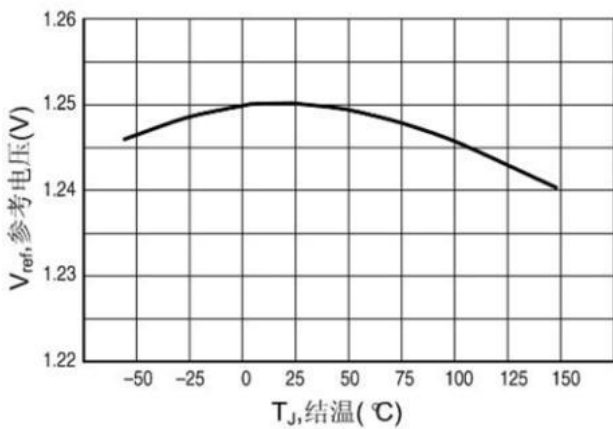

$$V_O = 1.25 V (1 + R_2 / R_1) + I_{ADJ}R_2$$

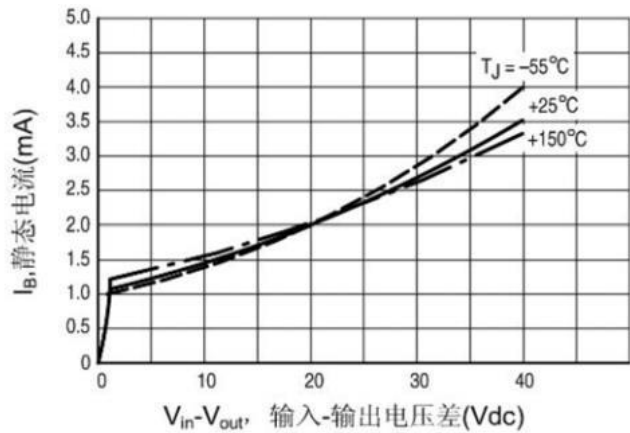
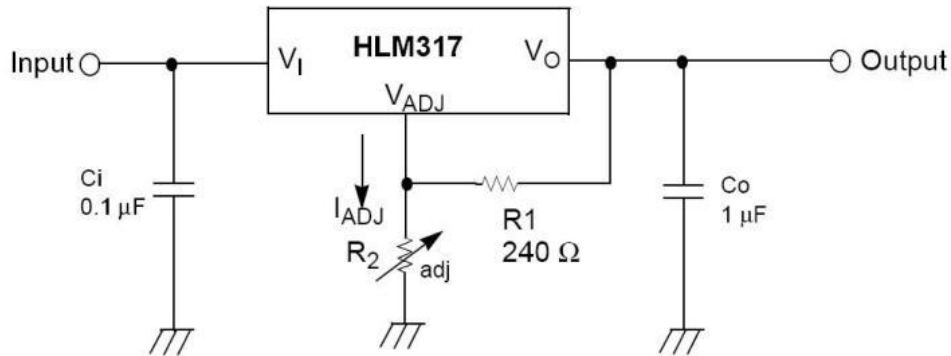
图 8. 典型应用线路

Figure 7. Typical Application

注:

当稳压器离电源滤波器有一定距离时, C_i 是必需的。 C_o 对稳定性而言不必要, 但可改进瞬态响应。因为 I_{ADJ} 控制小于 $100\mu A$, 这一项误差在多数应用中可忽略。

C_i is required when the regulator is located an appreciable distance from power supply filter. C_o is not needed for stability; however, it does improve transient response. Since I_{ADJ} is controlled to less than $100\mu A$, the error associated with this term is negligible in most applications



NOTE:

1. Exceeding the maximum ratings of the device in performance may cause damage to the device, even the permanent failure, which may affect the dependability of the machine. Please do not exceed the absolute maximum ratings of the device when circuit designing.
2. When installing the heat sink, please pay attention to the torsional moment and the smoothness of the heat sink.
3. MOSFETs is the device which is sensitive to the static electricity, it is necessary to protect the device from being damaged by the static electricity when using it.
4. Shenzhen Minos reserves the right to make changes in this specification sheet and is subject to change without prior notice.

CONTACT:

深圳市迈诺斯科技有限公司（总部）

地址：深圳市福田区华富街道田面社区深南中路4026号田面城市大厦22B-22C

邮编：518025

电话：0755-83273777

X-ON Electronics

Largest Supplier of Electrical and Electronic Components

Click to view similar products for [LDO Voltage Regulators](#) category:

Click to view products by [Minos](#) manufacturer:

Other Similar products are found below :

[AP7363-SP-13](#) [NCV8664CST33T3G](#) [L79M05TL-E](#) [AP7362-HA-7](#) [PT7M8202B12TA5EX](#) [TCR3DF185,LM\(CT](#) [TLF4949EJ](#)
[NCP4687DH15T1G](#) [NCV8703MX30TCG](#) [LP2951CN](#) [NCV4269CPD50R2G](#) [AP7315-25W5-7](#) [NCV47411PAAJR2G](#) [AP2111H-1.2TRG1](#)
[ZLDO1117QK50TC](#) [AZ1117ID-ADJTRG1](#) [NCV4263-2CPD50R2G](#) [NCP114BMX075TCG](#) [MC33269T-3.5G](#) [TLE4471GXT](#) [AP7315-33SA-](#)
[7](#) [NCV4266-2CST33T3G](#) [NCP715SQ15T2G](#) [NCV8623MN-50R2G](#) [NCV563SQ18T1G](#) [NCV8664CDT33RKG](#) [NCV4299CD250R2G](#)
[NCP715MX30TBG](#) [NCV8702MX25TCG](#) [L974113TR](#) [TLE7270-2E](#) [NCV562SQ25T1G](#) [AP2213D-3.3TRG1](#) [AP2202K-2.6TRE1](#)
[NCV8170BMX300TCG](#) [NCV8152MX300180TCG](#) [NCP700CMT45TBG](#) [AP7315-33W5-7](#) [LD56100DPU28R](#) [NCP154MX180300TAG](#)
[AP2210K-3.0TRE1](#) [AP2113AMTR-G1](#) [NJW4104U2-33A-TE1](#) [MP2013AGG-5-P](#) [NCV8775CDT50RKG](#) [NJM2878F3-45-TE1](#) [S-](#)
[19214B00A-V5T2U7](#) [S-19214B50A-V5T2U7](#) [S-19213B50A-V5T2U7](#) [S-19214BC0A-E8T1U7*1](#)