

## Description

MD100N20 the silicon N-channel Enhanced MOSFETs, is obtained by advanced MOSFET technology which reduce the conduction loss, improve switching performance and enhance the avalanche energy. The transistor is suitable device for SMPS, High speed switching and general purpose application

## General Features

- ①  $V_{DS}=200V, I_D=100A$   $R_{DS(ON)} < 28m\Omega @ V_{GS}=10V$
- ② Fast Switching
- ③ Low  $C_{rss}$
- ④ 100% avalanche tested
- ⑤ Improved  $dv/dt$  capability
- ⑥ RoHS product

## Application

- ① High frequency switching mode power supply

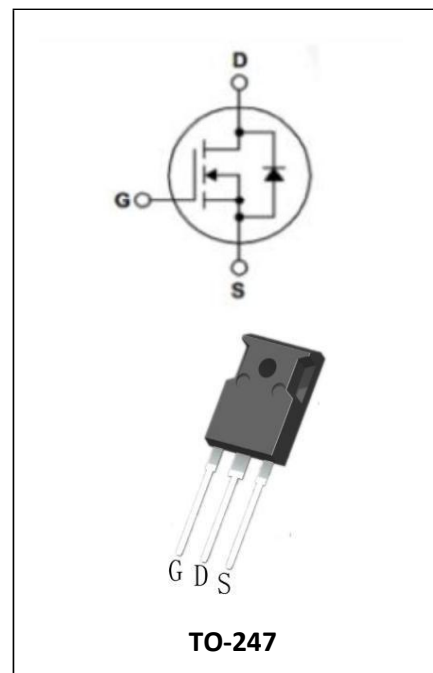

## Package Marking And Ordering Information:

Ordering Codes	Package	Product Code	Packing
MD100N20	TO-247	MD100N20	Tube

## Absolute Maximum Ratings @ $T_a=25^\circ\text{C}$ (unless otherwise specified)

Symbol	Parameter	Rating	Units
$V_{DSS}$	Drain-to-Source Voltage	200	V
$I_D$	Continuous Drain Current	100	A
	Continuous Drain Current $T_c = 100^\circ\text{C}$	50	A
$I_{DM}$	Pulsed Drain Current(Note1)	320	A
$V_{GS}$	Gate-to-Source Voltage	$\pm 30$	V
$E_{AS}$	Single Pulse Avalanche Energy(Note2)	2600	mJ
$dv/dt$	Peak Diode Recovery $dv/dt$ (Note3)	5.0	V/ns
$P_D$	Power Dissipation TO-3PN\TO-247	390	W
	Derating Factor above $25^\circ\text{C}$	3.13	W/ $^\circ\text{C}$
$T_J, T_{stg}$	Operating Junction and Storage Temperature Range	150, $-55$ to $150$	$^\circ\text{C}$

$T_L$	Maximum Temperature for Soldering	300	$^{\circ}\text{C}$
-------	-----------------------------------	-----	--------------------

### Thermal characteristics

#### Thermal characteristics (No FullPAK) TO-247

Symbol	Parameter	RATINGS	Units
$R_{\theta JC}$	Junction-to-Case	0.32	$^{\circ}\text{C}/\text{W}$
$R_{\theta JA}$	Junction-to-Ambient	40	$^{\circ}\text{C}/\text{W}$

### Electrical Characteristics at $T_C = 25^{\circ}\text{C}$ , unless otherwise specified

OFF Characteristics						
Symbol	Parameter	Test Conditions	Values			Units
			Min.	Typ.	Max.	
$V_{DSS}$	Drain to Source Breakdown Voltage	$V_{GS}=0\text{V}$ , $I_D=250\mu\text{A}$	200	--	--	V
$\Delta BV_{DSS}/\Delta T_J$	$B_{vdss}$ Temperature Coefficient	$I_D=250\mu\text{A}$ , Reference 25	--	0.25	--	$\text{V}/^{\circ}\text{C}$
$I_{DSS}$	Drain to Source Leakage Current	$V_{DS}=200\text{V}$ , $V_{GS}=0\text{V}$ , $T_j=25^{\circ}\text{C}$	--	--	1	$\mu\text{A}$
		$V_{DS}=160\text{V}$ , $V_{GS}=0\text{V}$ , $T_j=125^{\circ}\text{C}$	--	--	10	$\mu\text{A}$
$I_{GSS(F)}$	Gate to Source Forward Leakage	$V_{GS}=+30\text{V}$	--	--	100	nA
$I_{GSS(R)}$	Gate to Source Reverse Leakage	$V_{GS}=-30\text{V}$	--	--	100	nA

ON Characteristics						
Symbol	Parameter	Test Conditions	Values			Units
			Min.	Typ.	Max.	
$R_{DS(ON)}$	Drain-to-Source On- Resistance	$V_{GS}=10\text{V}$ , $I_D=40\text{A}(\text{Note4})$	--	23	28	$\text{m}\Omega$
$V_{GS(TH)}$	Gate Threshold Voltage	$V_{DS}=V_{GS}$ , $I_D=250\mu\text{A}(\text{Note4})$	2.0	--	4.0	V
$g_{fs}$	Forward Transconductance	$V_{DS}=15\text{V}$ , $I_D=40\text{A}(\text{Note4})$	--	50	--	S



迈诺斯科技

MD100N20

Dynamic Characteristics						
Symbol	Parameter	Test Conditions	Values			Units
			Min.	Typ.	Max.	
$R_g$	Gate resistance	$f = 1.0\text{MHz}$	--	0.95	--	$\Omega$
$C_{iss}$	Input Capacitance	$V_{GS}=0V$ $V_{DS}=25V$ $f=1.0\text{MHz}$	--	9650	--	PF
$C_{oss}$	Output Capacitance		--	968	--	
$C_{rss}$	Reverse Transfer Capacitance		--	57	--	

Switching Characteristics						
Symbol	Parameter	Test Conditions	Values			Units
			Min.	Typ.	Max.	
$t_{d(ON)}$	Turn-on Delay Time	$I_D = 100A$ $V_{DD} = 100V$ $V_{GS} = 10V$ $R_G = 20\Omega$	--	60	--	ns
$t_r$	Rise Time		--	250	--	
$t_{d(OFF)}$	Turn-Off Delay Time		--	92	--	
$t_f$	Fall Time		--	118	--	
$Q_g$	Total Gate Charge	$I_D = 100A$ $V_{DD} = 160V$ $V_{GS} = 10V$	--	152	--	nC
$Q_{gs}$	Gate to Source Charge		--	56	--	
$Q_{gd}$	Gate to Drain ("Miller") Charge		--	39.5	--	

Source-Drain Diode Characteristics						
Symbol	Parameter	Test Conditions	Values			Units
			Min.	Typ.	Max.	
$I_S$	Continuous Source Current (Body Diode)	$TC=25^\circ C$	--	--	100	A
$I_{SM}$	Maximum Pulsed Current (Body Diode)		--	--	320	A
$V_{SD}$	Diode Forward Voltage	$I_S=100A,$ $V_{GS}=0V(\text{Note4})$	--	--	1.2	V
$T_{rr}$	Reverse Recovery Time	$I_S=100A,$ $T_j = 25^\circ C$ $dI_F/dt=100A/us,$ $V_{GS}=0V$	--	192	--	ns
$Q_{rr}$	Reverse Recovery Charge		--	1853	--	nC
$I_{rrm}$	Reverse Recovery Current		--	19.3	--	A

Note1: Pulse width limited by maximum junction temperature

Note2:  $L=20\text{mH}$ ,  $V_{DS}=50V$ , Start  $T_J=25^\circ C$

Note3:  $I_{SD} = 100A, di/dt \leq 100A/us, V_{DD} \leq BV_{DS}$ , Start  $T_J=25$

Note4: Pulse width  $t_p \leq 300\mu s$ ,  $\delta \leq 2\%$



### Characteristics Curves

Figure 1a Safe Operating Area

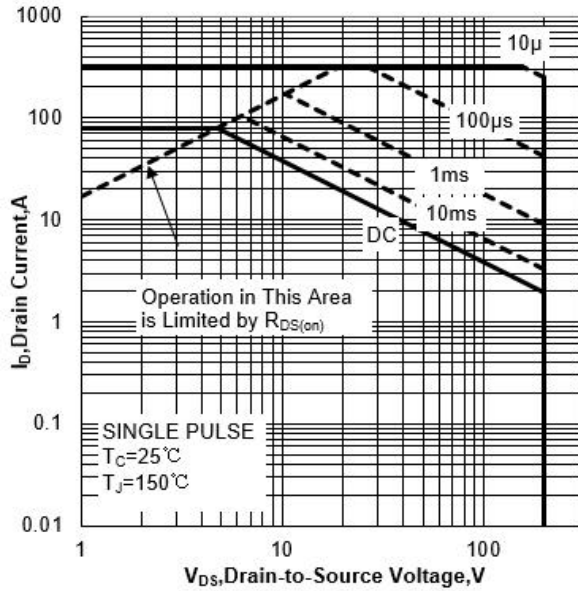

Figure 2 Power Dissipation

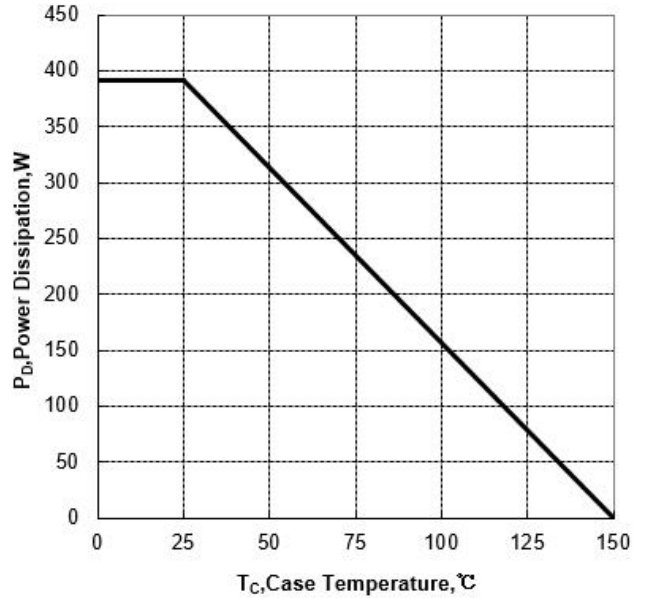

Figure 3 Max Thermal Impedance

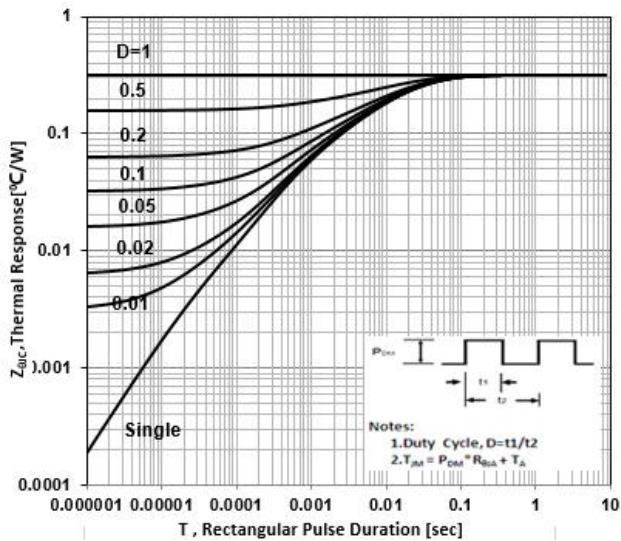

Figure 4 Typical Output Characteristics

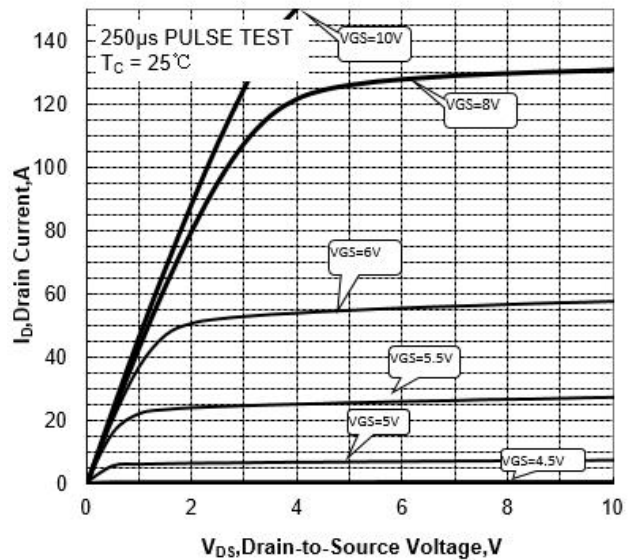

Figure 5 Typical Transfer Characteristics

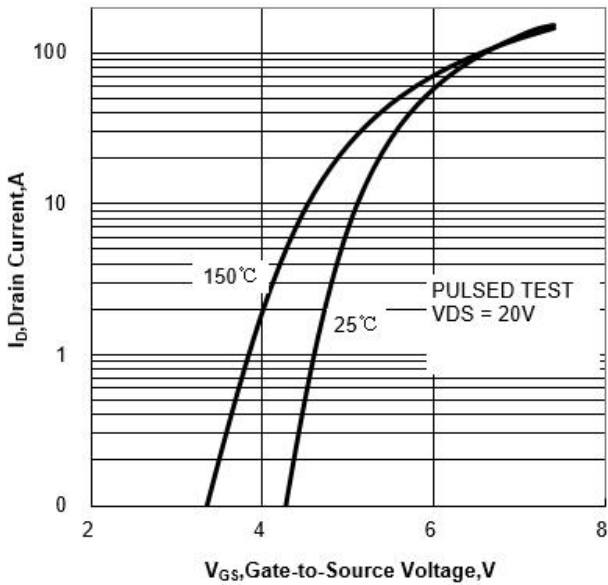

Figure 6 Typical Drain to Source ON Resistance vs Drain Current

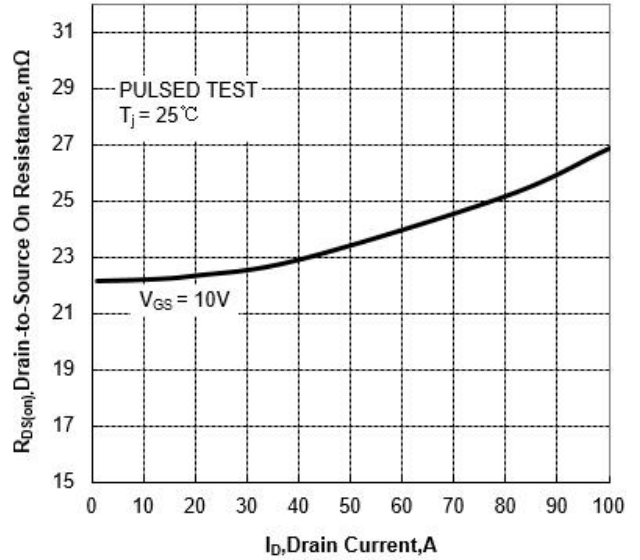

Figure 7 Typical Drain to Source on Resistance vs Junction Temperature

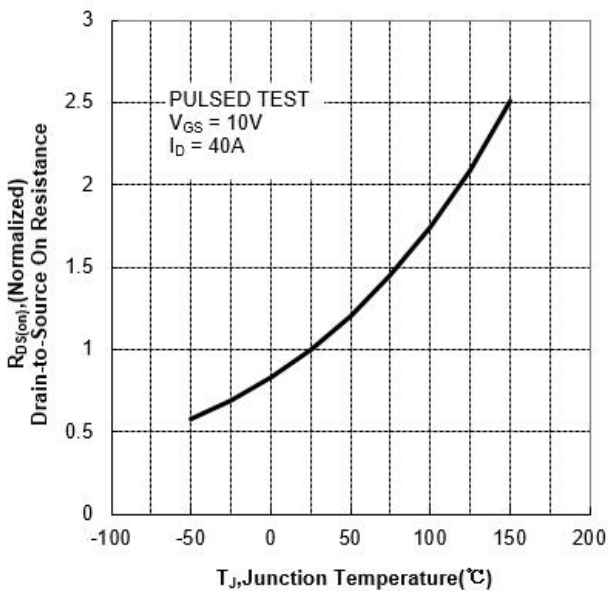

Figure 8 Typical Theshold Voltage vs Junction Temperature

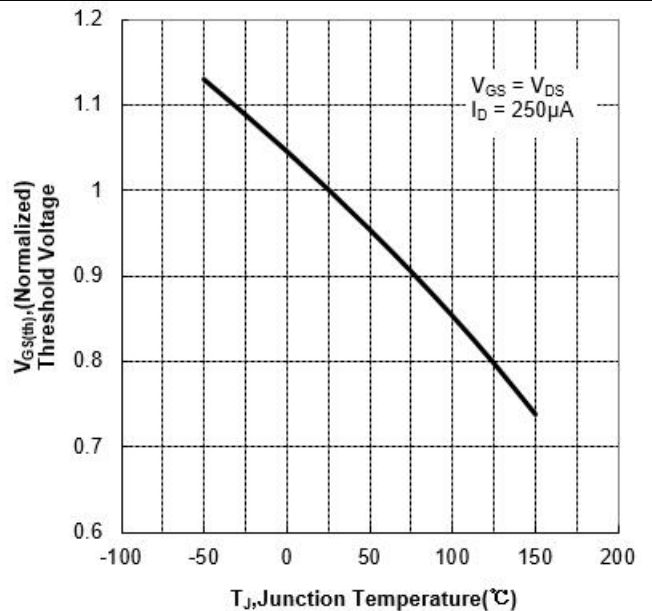

Figure 9 Typical Breakdown Voltage vs Junction Temperature

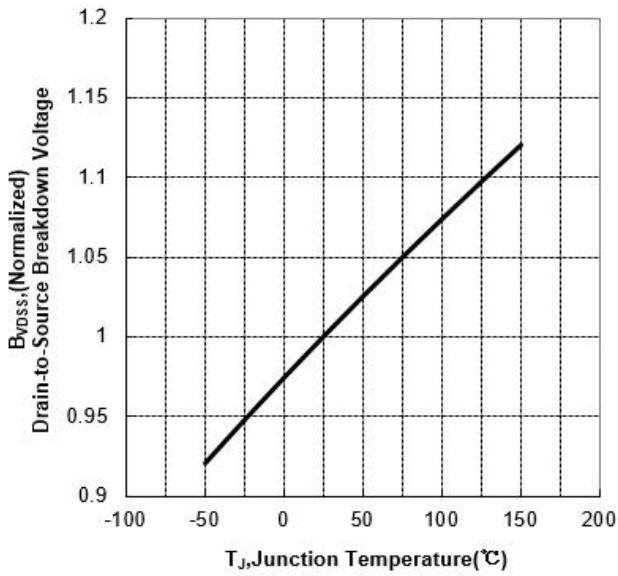

Figure 10 Typical Capacitance vs Drain to Source Voltage

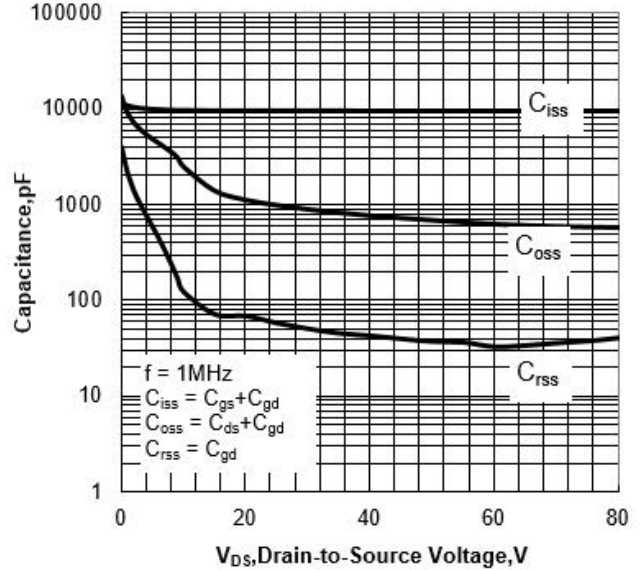
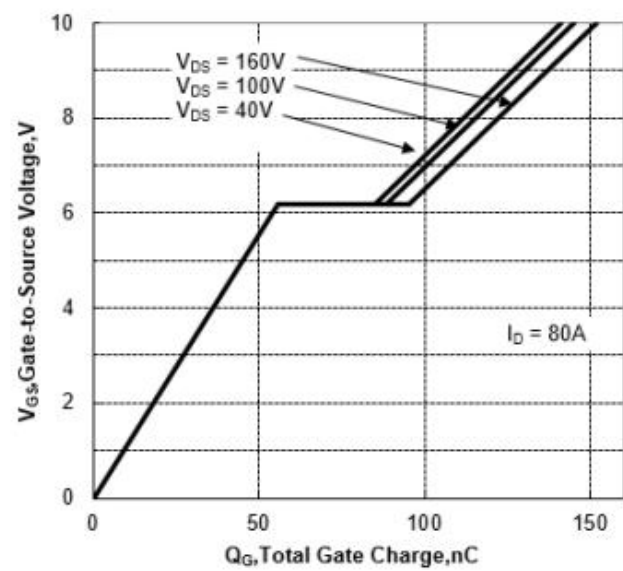

Figure 11 Typical Gate Charge vs Gate to Source Voltage



Test Circuit and Waveform

Figure 12 Gate Charge Test Circuit

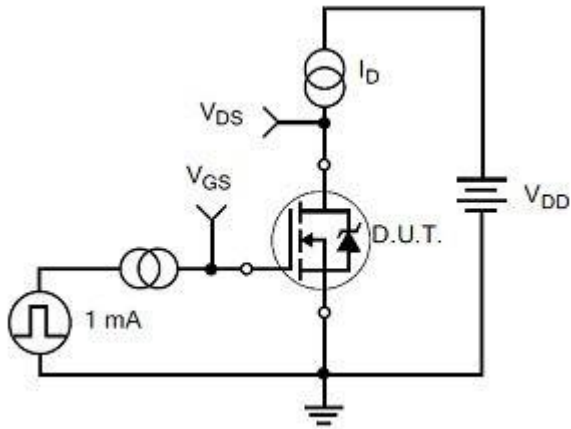

Figure 13 Gate Charge Waveforms

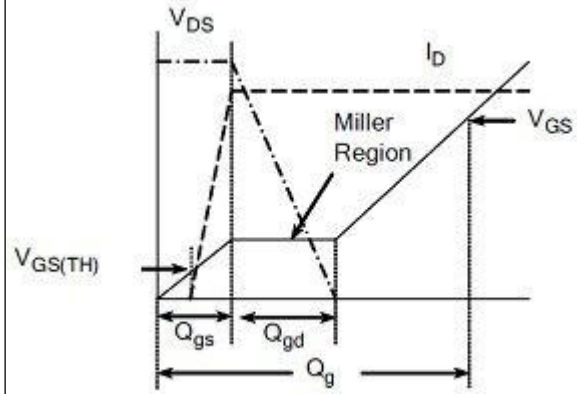

Figure 14 Resistive Switching Test Circuit

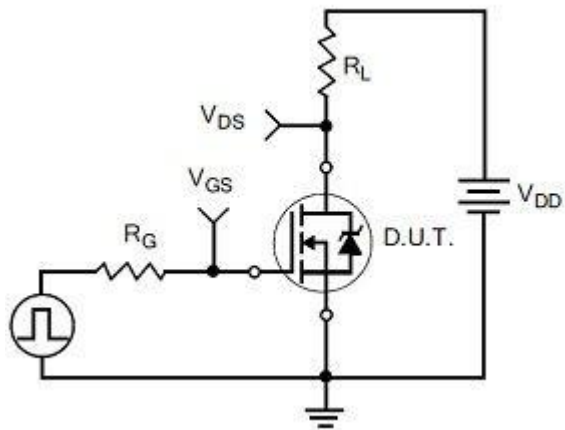

Figure 15 Resistive Switching Waveforms

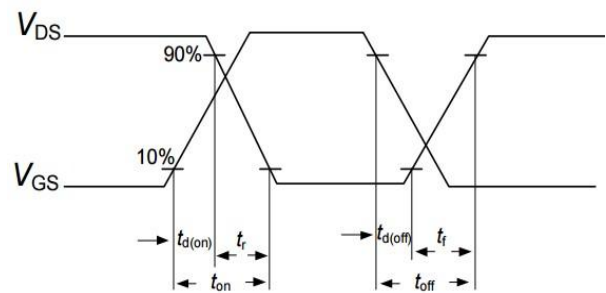

Figure 16 Diode Reverse Recovery Test Circuit

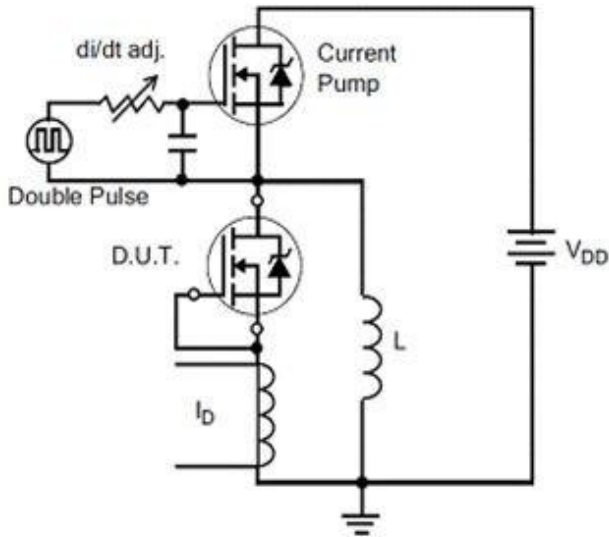

Figure 17 Diode Reverse Recovery Waveform

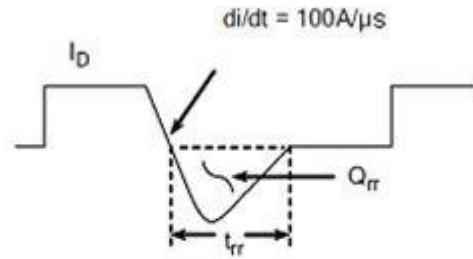

Figure 18 Unclamped Inductive Switching Test Circuit

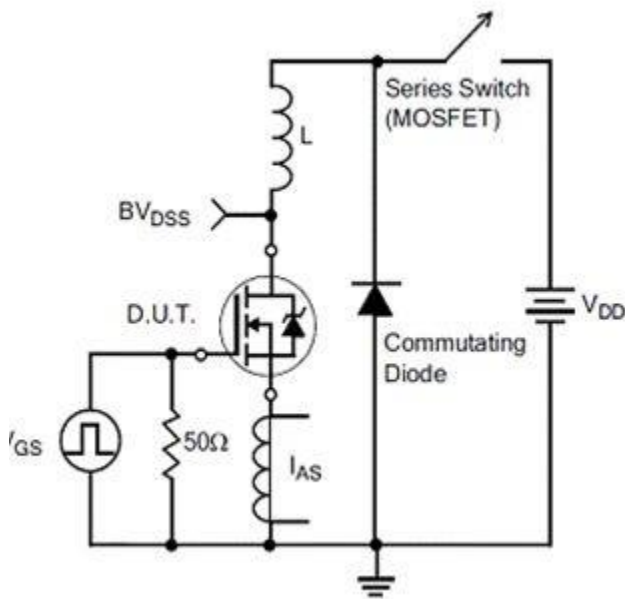
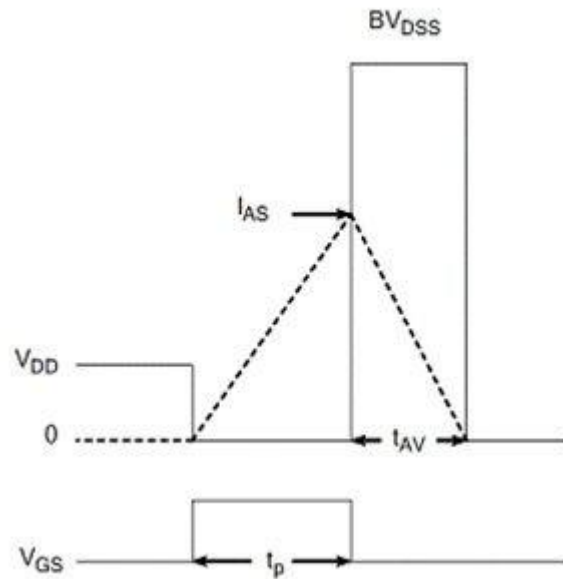
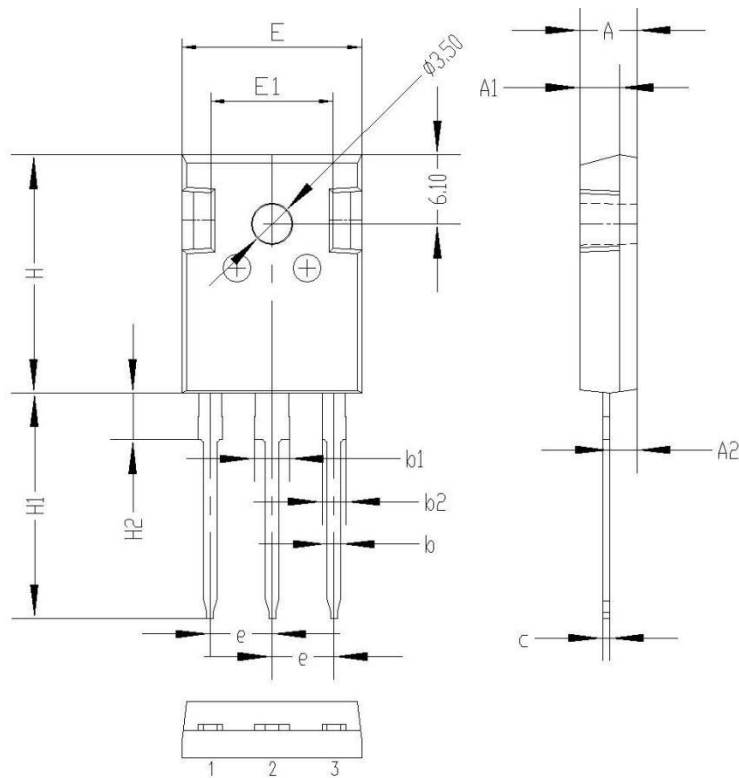

Figure 19 Unclamped Inductive Switching Waveform





Package Description



Symbol	Unit mm		
	Min	Typ	Max
A	4.8	5.00	5.20
A1	3.3	3.5	3.7
A2	2.20	2.40	2.60
b	1.00	1.2	1.40
b1	2.90	3.10	3.30
b2	1.80	2.00	2.20
c	0.50	0.60	0.70
e	5.25	5.45	5.65
E	15.2	15.7	16.2
H	20.8	21	21.2
H1	19.5	20.0	20.5
H2	3.9	4.1	4.3
G	5.9	6.1	6.3
$\Phi P$	3.30	3.50	3.70

TO-247 Package



**NOTE:**

1. Exceeding the maximum ratings of the device in performance may cause damage to the device, even the permanent failure, which may affect the dependability of the machine. Please do not exceed the absolute maximum ratings of the device when circuit designing.
2. When installing the heat sink, please pay attention to the torsional moment and the smoothness of the heat sink.
3. MOSFETs is the device which is sensitive to the static electricity, it is necessary to protect the device from being damaged by the static electricity when using it.
4. Shenzhen Minos reserves the right to make changes in this specification sheet and is subject to change without prior notice.

**CONTACT:**

**深圳市迈诺斯科技有限公司（总部）**

地址：深圳市福田区华富街道田面社区深南中路4026号田面城市大厦22B-22C

邮编：518025

电话：0755-83273777

## X-ON Electronics

Largest Supplier of Electrical and Electronic Components

*Click to view similar products for [MOSFET](#) category:*

*Click to view products by [Minos](#) manufacturer:*

Other Similar products are found below :

[IRFD120](#) [IRFY240C](#) [JANTX2N5237](#) [2SK2267\(Q\)](#) [BUK455-60A/B](#) [MIC4420CM-TR](#) [VN1206L](#) [NDP4060](#) [SI4482DY](#)  
[IPS70R2K0CEAKMA1](#) [SQD23N06-31L-GE3](#) [TK16J60W,S1VQ\(O](#) [2SK2614\(TE16L1,Q\)](#) [DMN1017UCP3-7](#) [EFC2J004NUZTDG](#)  
[DMN1053UCP4-7](#) [SQJ469EP-T1-GE3](#) [NTE2384](#) [DMC2700UDMQ-7](#) [DMN2080UCB4-7](#) [DMN61D9UWQ-13](#) [US6M2GTR](#)  
[DMN31D5UDJ-7](#) [DMP22D4UFO-7B](#) [DMN1006UCA6-7](#) [DMN16M9UCA6-7](#) [STF5N65M6](#) [IRF40H233XTMA1](#) [STU5N65M6](#)  
[DMN6022SSD-13](#) [DMN13M9UCA6-7](#) [DMTH10H4M6SPS-13](#) [DMN2990UFB-7B](#) [IPB80P04P405ATMA2](#) [2N7002W-G](#) [MCAC30N06Y-](#)  
[TP](#) [MCQ7328-TP](#) [NTMC083NP10M5L](#) [NVMFS2D3P04M8LT1G](#) [BXP7N65D](#) [BXP4N65F](#) [AOL1454G](#) [WMJ80N60C4](#) [BXP2N20L](#)  
[BXP2N65D](#) [BXT1150N10J](#) [BXT1700P06M](#) [TSM60NB380CP](#) [ROG](#) [RQ7L055BGTCR](#) [DMNH15H110SK3-13](#)