

Silicon N-Channel Power MOSFET

Description

MD23N50 the silicon N-channel Enhanced MOSFETs, is obtained by advanced MOSFET technology which reduce the conduction loss, improve switching performance and enhance the avalanche energy. The transistor is suitable device for SMPS, high speed switching and general purpose applications.

General Features

- ① $V_{DS}=500V$, $R_{dson}<260m\Omega$ @ $V_{GS}=10V$, $I_D=23A$ (Typ:220m Ω)
- ② Fast Switching
- ③ Low Crss (typical 18pF)
- ④ 100% avalanche tested
- ⑤ Improved dv/dt capability
- ⑥ RoHS product

Application

- ① High frequency switching mode power supply

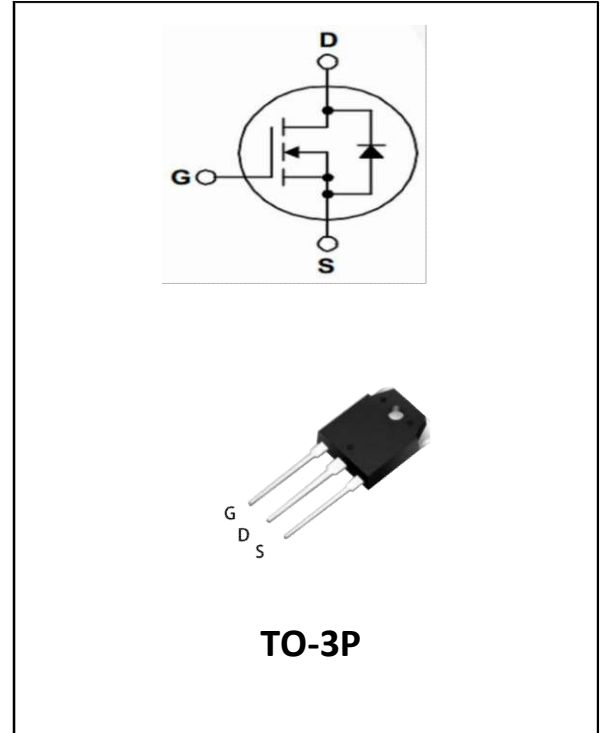

Package Marking And Ordering Information:

Ordering Codes	Package	Product Code	Packing
MD23N50	TO-3P	MD23N50	Tube

ABSOLUTE RATINGS @ Ta=25°C (unless otherwise specified)

Symbol	Parameter	Rating	Units
V_{DSS}	Drain-to-Source Voltage	500	V
I_D	Continuous Drain Current	23	A
	Continuous Drain Current $T_c = 100^\circ C$	12.6	A
I_{DM}	Pulsed Drain Current(Note1)	80	A
V_{GS}	Gate-to-Source Voltage	± 30	V
E_{AS}	Single Pulse Avalanche Energy(Note2)	1200	mJ
dv/dt	Peak Diode Recovery dv/dt(Note3)	5.0	V/ns
P_D	Power Dissipation TO-220, TO-3PN	230	W
	Derating Factor above 25°C	1.85	W/°C
P_D	Power Dissipation TO-220F, TO-3PF	48	W
	Derating Factor above 25°C	0.38	W/°C
T_J, T_{stg}	Operating Junction and Storage Temperature Range	150, -55 to 150	°C

T_L	Maximum Temperature for Soldering	300	°C
-------	-----------------------------------	-----	----

Thermal characteristics

Thermal characteristics (No FullPAK) TO-3PN

Symbol	Parameter	RATINGS	Units
$R_{\theta JC}$	Junction-to-Case	0.54	°C/W
$R_{\theta JA}$	Junction-to-Ambient	62.5	°C/W

Thermal characteristics (FullPAK) TO-3PF

Symbol	Parameter	RATINGS	Units
$R_{\theta JC}$	Junction-to-Case	2.6	°C/W
$R_{\theta JA}$	Junction-to-Ambient	62.5	°C/W

Electrical Characteristics at $T_c = 25^\circ\text{C}$, unless otherwise specified

OFF Characteristics						
Symbol	Parameter	Test Conditions	Values			Units
			Min.	Typ.	Max.	
V_{DSS}	Drain to Source Breakdown Voltage	$V_{GS}=0V$, $I_b=250\mu A$	500	--	--	V
$\Delta BV_{DSS}/\Delta T_j$	Bvdss Temperature Coefficient	$I_D=250\mu A$, Reference 25°C	--	0.6	--	V/°C
I_{DSS}	Drain to Source Leakage Current	$V_{DS}=500V$, $V_{GS}=0V$, $T_j = 25^\circ\text{C}$	--	--	10	μA
		$V_{DS}=400V$, $V_{GS}=0V$, $T_j = 125^\circ\text{C}$	--	--	100	μA
$I_{GSS(F)}$	Gate to Source Forward Leakage	$V_{GS}=+30V$	--	--	100	nA
$I_{GSS(R)}$	Gate to Source Reverse Leakage	$V_{GS}=-30V$	--	--	-100	nA
ON Characteristics						
Symbol	Parameter	Test Conditions	Values			Units
			Min.	Typ.	Max.	
$R_{DS(ON)}$	Drain-to-Source On-Resistance	$V_{GS}=10V$, $I_D=10A$ (Note4)	--	0.22	0.26	Ω
$V_{GS(TH)}$	Gate Threshold Voltage	$V_{DS} = V_{GS}$, $I_D = 250\mu A$ (Note4)	2.0	--	4.0	V
g_{fs}	Forward Trans conductance	$V_{DS}=20V$, $I_D=10A$ (Note4)	--	12	--	S

Dynamic Characteristics						
Symbol	Parameter	Test Conditions	Values			Units
			Min.	Typ.	Max.	
R_g	Gate resistance	$f = 1.0\text{MHz}$	--	1.5	--	Ω
C_{iss}	Input Capacitance	$V_{GS} = 0V$ $V_{DS} = 25V$ $f = 1.0\text{MHz}$	--	1920	--	PF
C_{oss}	Output Capacitance		--	290	--	
C_{rss}	Reverse Transfer Capacitance		--	18	--	
Switching Characteristics						
Symbol	Parameter	Test Conditions	Values			Units
			Min.	Typ.	Max.	
$t_{d(ON)}$	Turn-on Delay Time	$I_D = 23A$ $V_{DD} = 250V$ $V_{GS} = 10V$ $R_G = 20\Omega$	--	33	--	ns
t_r	Rise Time		--	75	--	
$t_{d(OFF)}$	Turn-Off Delay Time		--	91	--	
t_f	Fall Time		--	83	--	
Q_g	Total Gate Charge	$I_D = 23A$ $V_{DD} = 400V$ $V_{GS} = 10V$	--	56	--	nC
Q_{gs}	Gate to Source Charge		--	13	--	
Q_{gd}	Gate to Drain ("Miller") Charge		--	20	--	
Source-Drain Diode Characteristics						
Symbol	Parameter	Test Conditions	Values			Units
			Min.	Typ.	Max.	
I_S	Continuous Source Current (Body Diode)	$T_C = 25^\circ C$	--	--	23	A
I_{SM}	Maximum Pulsed Current (Body Diode)		--	--	80	A
V_{SD}	Diode Forward Voltage	$I_S = 23A, V_{GS} = 0V(\text{Note4})$	--	--	1.2	V
T_{rr}	Reverse Recovery Time	$I_S = 23A,$ $T_J = 25^\circ C$ $d_i/d_t = 100A/\mu s,$ $V_{GS} = 0V$	--	536	--	ns
Q_{rr}	Reverse Recovery Charge		--	5668	--	nC
I_{rrm}	Reverse Recovery Current		--	21.1	--	A

Note1: Pulse width limited by maximum junction temperature

Note2: $L=10\text{mH}, V_{DS}=50V, \text{Start } T_J=25^\circ C$

Note3: $I_{SD} = 23A, d_i/d_t \leq 100A/\mu s, V_{DD} \leq B_{VDS}, \text{Start } T_J=25^\circ C$

Note4: Pulse width $t_p \leq 300\mu s, \delta \leq 2\%$

Characteristics Curves

Figure 1a Safe Operating Area (No FullPAK)

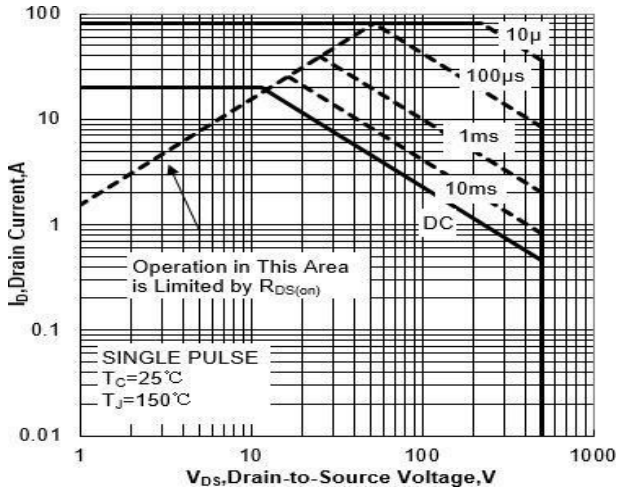

Figure 1b Safe Operating Area (FullPAK)

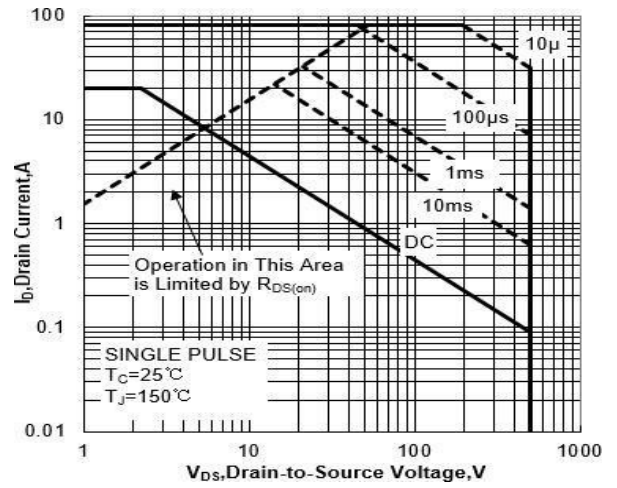

Figure 2a Power Dissipation (No FullPAK)

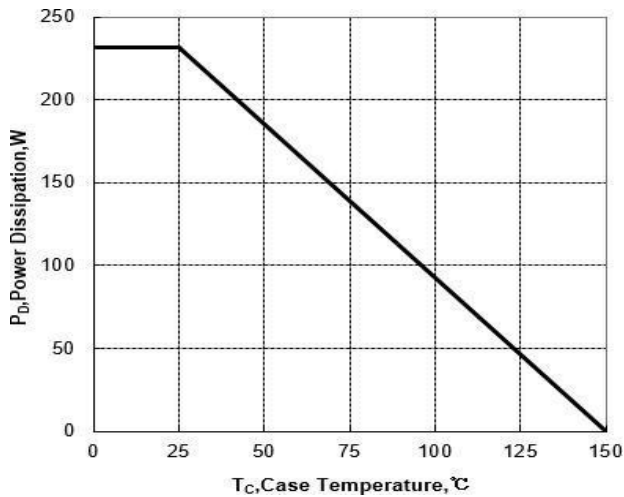

Figure 2b Power Dissipation (FullPAK)

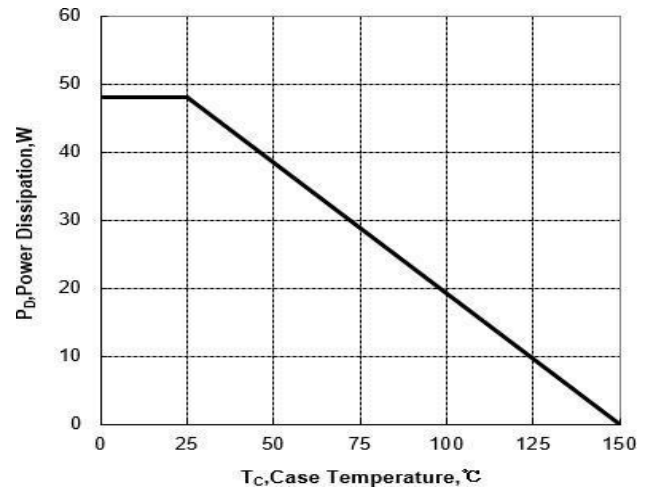

Figure 3a Max Thermal Impedance (No FullPAK)

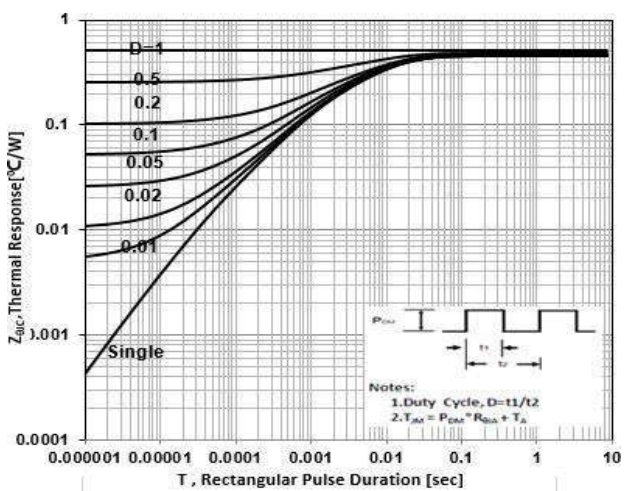

Figure 3b Max Thermal Impedance (FullPAK)

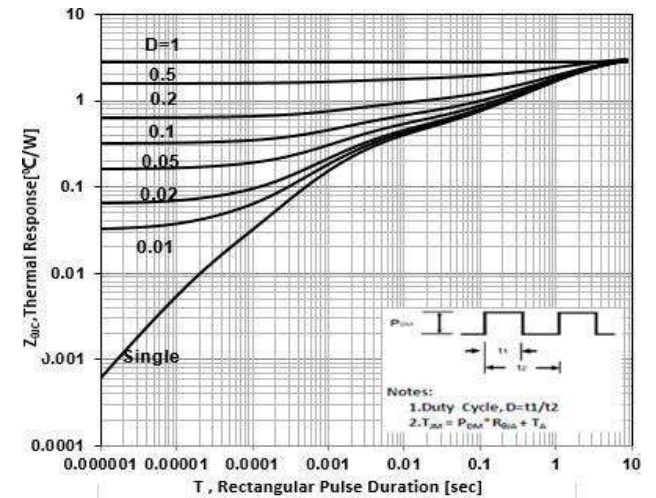

Figure 4 Typical Output Characteristics

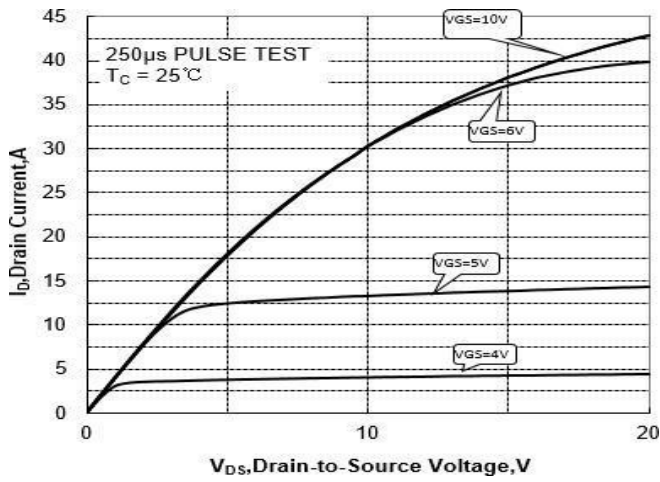

Figure 5 Typical Transfer Characteristics

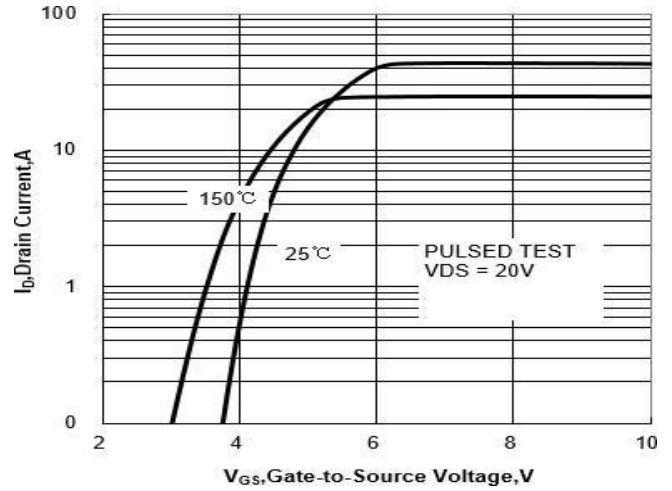

Figure 6 Typical Drain to Source ON Resistance vs Drain Current

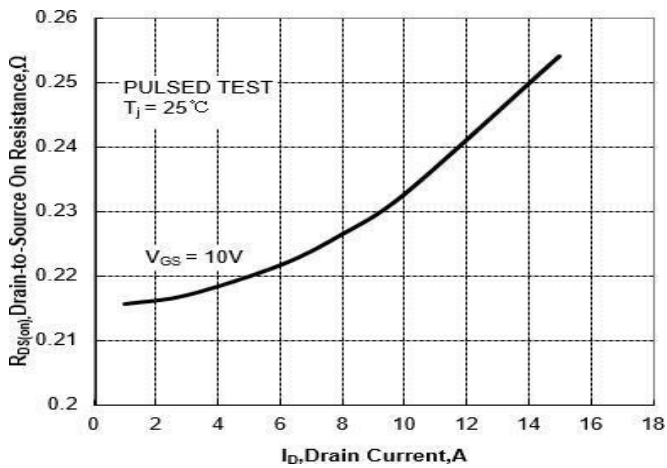

Figure 7 Typical Drain to Source on Resistance vs Junction Temperature

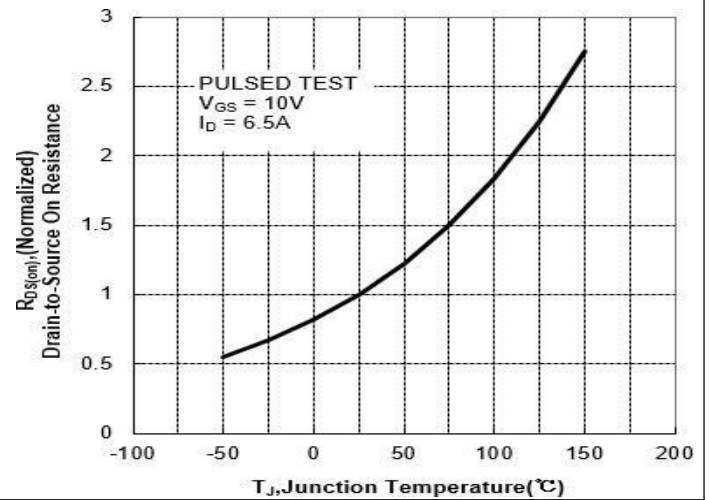

Figure 8 Typical Theshold Voltage vs Junction Temperature

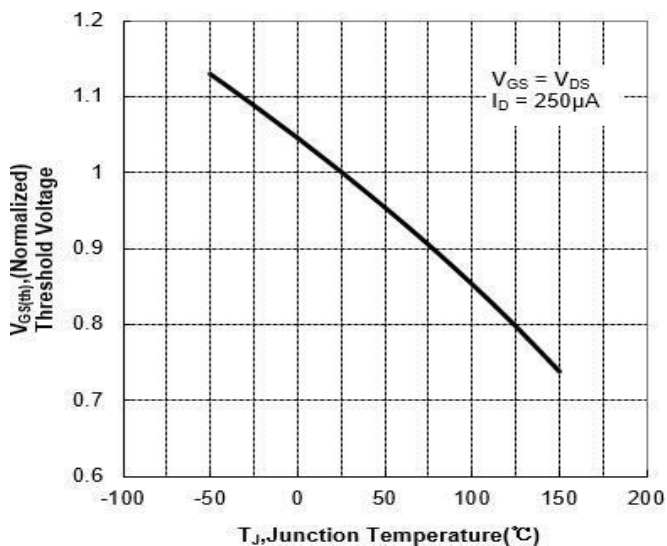

Figure 9 Typical Breakdown Voltage vs Junction Temperature

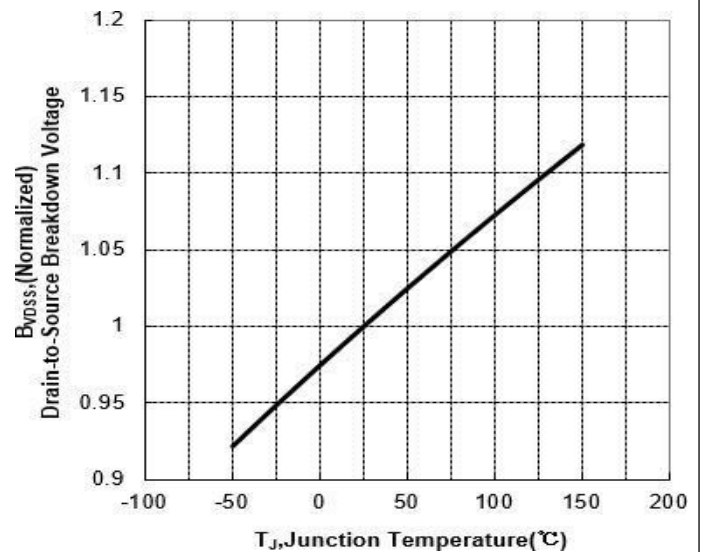

Figure 10 Typical Capacitance vs Drain to Source Voltage

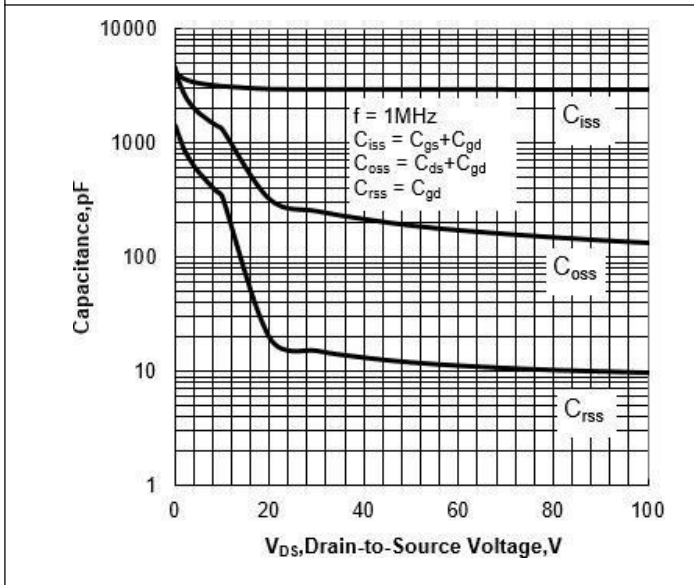
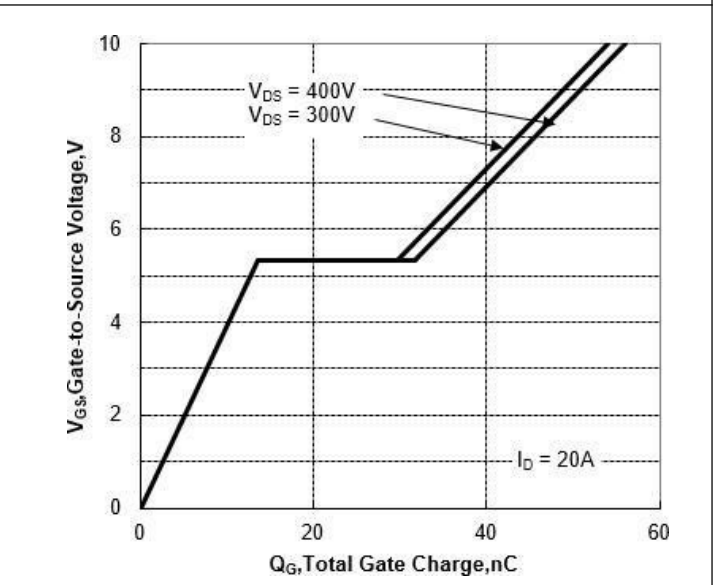

Figure 11 Typical Gate Charge vs Gate to Source Voltage



Test Circuit and Waveform

Figure 12 Gate Charge Test Circuit

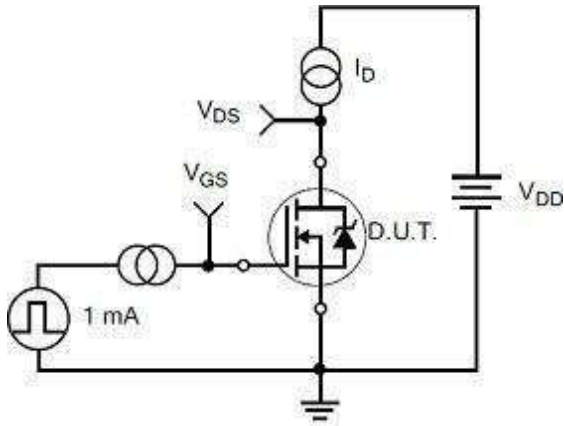

Figure 13 Gate Charge Waveforms

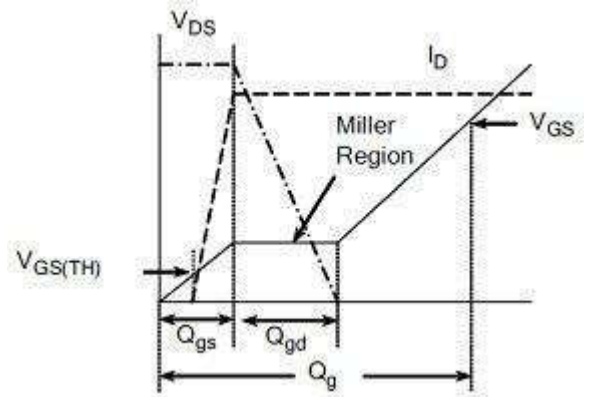

Figure 14 Resistive Switching Test Circuit

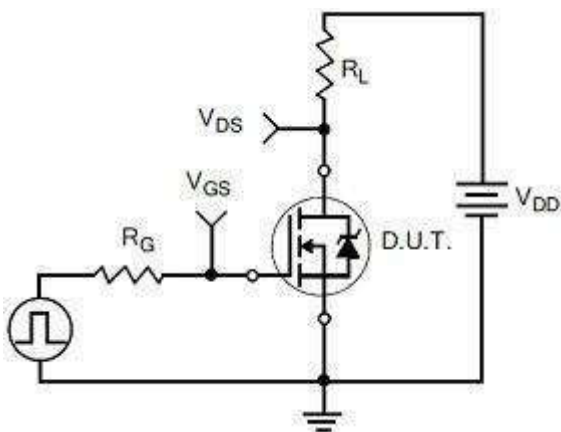

Figure 15 Resistive Switching Waveforms

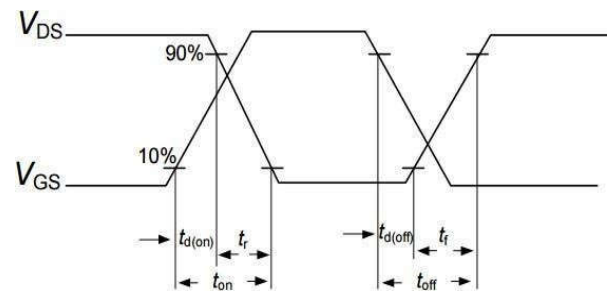

Figure 16 Diode Reverse Recovery Test Circuit

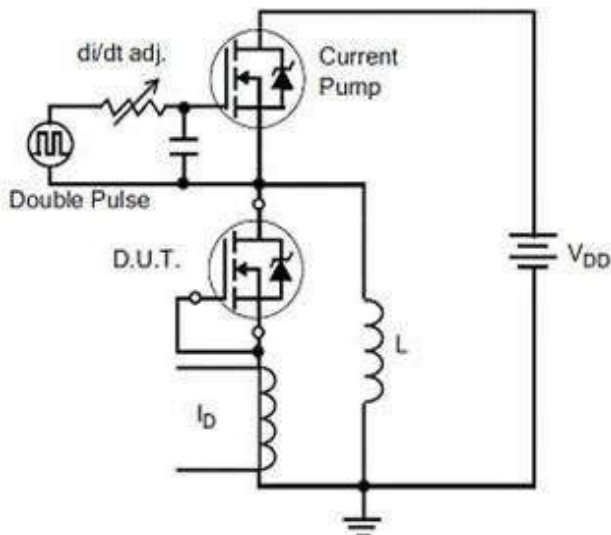

Figure 17 Diode Reverse Recovery Waveform

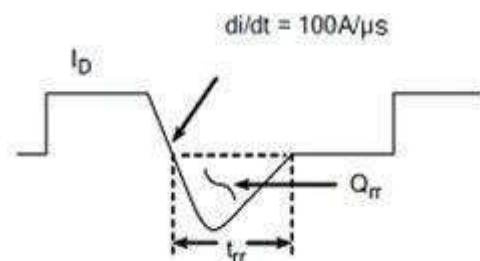
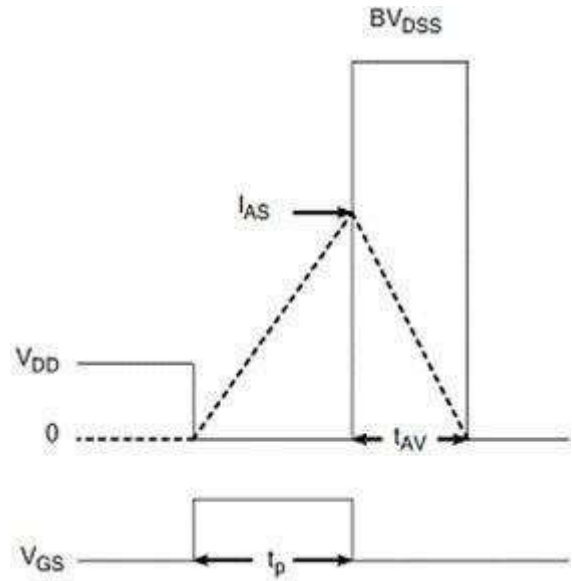
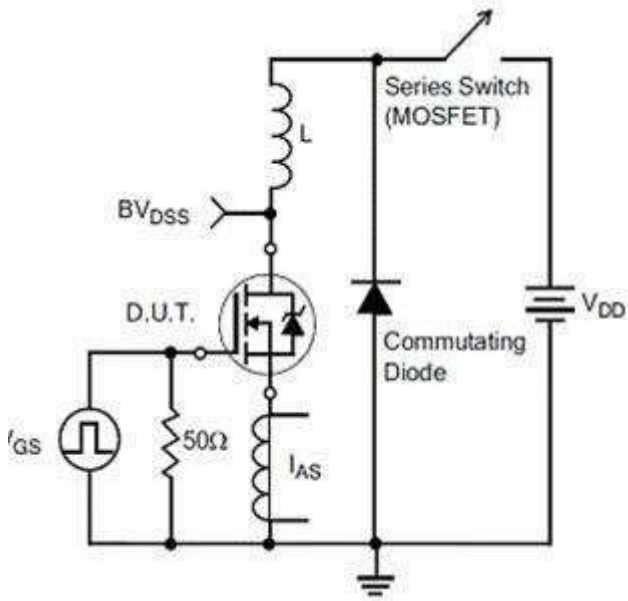
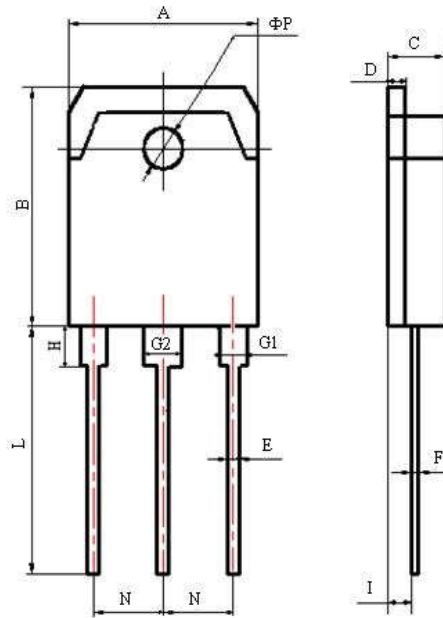

Figure 18 Unclamped Inductive Switching Test Circuit

Figure 19 Unclamped Inductive Switching Waveform



Package Description



Items	Values(mm)	
	MIN	MAX
A	15.00	16.00
B	19.20	20.60
C	4.60	5.00
D	1.40	1.60
E	0.90	1.10
F	0.50	0.70
G1	2.00	2.20
G2	3.00	3.20
H	3.00	3.70
I	1.20	1.70
	2.70	2.90
L	19.00	21.00
N	5.25	5.65
ΦP	3.10	3.30

TO-3P Package



NOTE:

1. Exceeding the maximum ratings of the device in performance may cause damage to the device, even the permanent failure, which may affect the dependability of the machine. Please do not exceed the absolute maximum ratings of the device when circuit designing.
2. When installing the heat sink, please pay attention to the torsional moment and the smoothness of the heat sink.
3. MOSFETs is the device which is sensitive to the static electricity, it is necessary to protect the device from being damaged by the static electricity when using it.
4. Shenzhen Minos reserves the right to make changes in this specification sheet and is subject to change without prior notice.

CONTACT:

深圳市迈诺斯科技有限公司（总部）

地址：深圳市福田区华富街道田面社区深南中路4026号田面城市大厦22B-22C

邮编：518025

电话：0755-83273777

X-ON Electronics

Largest Supplier of Electrical and Electronic Components

Click to view similar products for [MOSFET](#) category:

Click to view products by [Minos](#) manufacturer:

Other Similar products are found below :

[IRFD120](#) [IRFY240C](#) [JANTX2N5237](#) [2SK2267\(Q\)](#) [BUK455-60A/B](#) [MIC4420CM-TR](#) [VN1206L](#) [NDP4060](#) [SI4482DY](#)
[IPS70R2K0CEAKMA1](#) [SQD23N06-31L-GE3](#) [TK16J60W,S1VQ\(O](#) [2SK2614\(TE16L1,Q\)](#) [DMN1017UCP3-7](#) [EFC2J004NUZTDG](#)
[DMN1053UCP4-7](#) [SQJ469EP-T1-GE3](#) [NTE2384](#) [DMC2700UDMQ-7](#) [DMN2080UCB4-7](#) [DMN61D9UWQ-13](#) [US6M2GTR](#)
[DMN31D5UDJ-7](#) [DMP22D4UFO-7B](#) [DMN1006UCA6-7](#) [DMN16M9UCA6-7](#) [STF5N65M6](#) [IRF40H233XTMA1](#) [STU5N65M6](#)
[DMN6022SSD-13](#) [DMN13M9UCA6-7](#) [DMTH10H4M6SPS-13](#) [DMN2990UFB-7B](#) [IPB80P04P405ATMA2](#) [2N7002W-G](#) [MCAC30N06Y-](#)
[TP](#) [MCQ7328-TP](#) [NTMC083NP10M5L](#) [NVMFS2D3P04M8LT1G](#) [BXP7N65D](#) [BXP4N65F](#) [AOL1454G](#) [WMJ80N60C4](#) [BXP2N20L](#)
[BXP2N65D](#) [BXT1150N10J](#) [BXT1700P06M](#) [TSM60NB380CP](#) [ROG](#) [RQ7L055BGTCR](#) [DMNH15H110SK3-13](#)