

## Silicon N-Channel Power MOSFET

### Description

MDT18N20, the silicon N-channel Enhanced MOSFETs, is obtained by advanced MOSFET technology which reduce the conduction loss, improve switching performance and enhance the avalanche energy. The transistor is suitable device for SMPS, high speed switching and general purpose applications.

### KEY CHARACTERISTICS

- ①  $V_{DS}=200V, I_D=18A$   $R_{DS(ON)}<180m\Omega@V_{GS}=10V$
- ② Fast Switching
- ③ Low  $C_{rss}$
- ④ 100% avalanche tested Improved  $dv/dt$  capability
- ⑤ RoHS product

### APPLICATIONS

- ① High frequency switching mode power supply

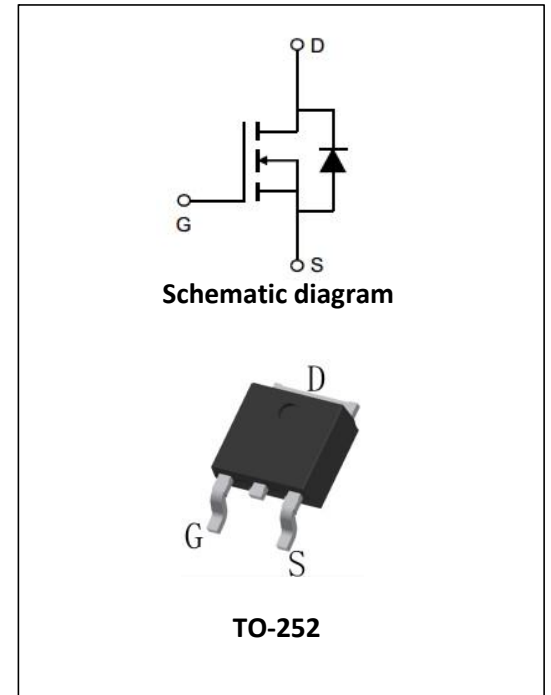

### ORDERING INFORMATION

Ordering Codes	Package	Product Code	Packing
MDT18N20	TO-252	MDT18N20	Tube

### ABSOLUTE RATINGS at $T_C=25^{\circ}C$ , unless otherwise specified

Symbol	Parameter	Rating	Units
$V_{DSS}$	Drain-to-Source Voltage	200	V
$I_D$	Continuous Drain Current	18	A
	Continuous Drain Current $T_C = 100^{\circ}C$	11	A
$I_{DM}$	Pulsed Drain Current(Note1)	72	A
$V_{GS}$	Gate-to-Source Voltage	$\pm 30$	V
$E_{AS}$	Single Pulse Avalanche Energy(Note2)	580	mJ
$dv/dt$	Peak Diode Recovery $dv/dt$ (Note3)	5.0	V/ns
$P_D$	Power Dissipation TO-220, TO-251, TO-252	130	W
	Derating Factor above $25^{\circ}C$	1.2	W/ $^{\circ}C$



P <sub>D</sub>	Power Dissipation TO-220F	42	W
	Derating Factor above 25°C	0.33	W/°C
T <sub>J</sub> , T <sub>stg</sub>	Operating Junction and Storage Temperature Range	150, -55 to 150	°C
T <sub>L</sub>	Maximum Temperature for Soldering	300	°C

**Thermal characteristics**

**Thermal characteristics (No FullPAK) TO-220\TO-251\TO-252**

Symbol	Parameter	RATINGS	Units
R <sub>θJC</sub>	Junction-to-Case	0.84	°C/W
R <sub>θJA</sub>	Junction-to-Ambient	62.5	°C/W

**Thermal characteristics (FullPAK) TO-220F**

Symbol	Parameter	RATINGS	Units
R <sub>θJC</sub>	Junction-to-Case	3.0	°C/W
R <sub>θJA</sub>	Junction-to-Ambient	62.5	°C/W

**Electrical Characteristics At TC=25°C, unless otherwise specified**

OFF Characteristics						
Symbol	Parameter	Test Conditions	Values			Units
			Min.	Typ.	Max.	
V <sub>DSS</sub>	Drain to Source Breakdown Voltage	V <sub>GS</sub> =0V, I <sub>D</sub> =250μA	200	--	--	V
ΔBV <sub>DSS</sub> /ΔT <sub>J</sub>	Bvdss Temperature Coefficient	I <sub>D</sub> =250uA, Reference 25°C	--	0.25	--	V/°C
I <sub>DSS</sub>	Drain to Source Leakage Current	V <sub>DS</sub> =200V, V <sub>GS</sub> = 0V, T <sub>J</sub> = 25°C	--	--	1	μA
		V <sub>DS</sub> =160V, V <sub>GS</sub> = 0V, T <sub>J</sub> = 125°C	--	--	100	μA
I <sub>GSS(F)</sub>	Gate to Source Forward Leakage	V <sub>GS</sub> =+30V	--	--	100	nA
I <sub>GSS(R)</sub>	Gate to Source Reverse Leakage	V <sub>GS</sub> =-30V	--	--	-100	nA



ON Characteristics						
Symbol	Parameter	Test Conditions	Values			Units
			Min.	Typ.	Max.	
$R_{DS(ON)}$	Drain-to-Source On-Resistance	$V_{GS}=10V,$ $I_D=7.5A(\text{Note4})$	--	0.13	0.18	$\Omega$
$V_{GS(TH)}$	Gate Threshold Voltage	$V_{DS} = V_{GS},$ $I_D = 250\mu A(\text{Note4})$	2.0	--	4.0	V
$g_{fs}$	Forward Transconductance	$V_{DS}=15V,$ $I_D=9A(\text{Note4})$	--	12	--	S
Dynamic Characteristics						
Symbol	Parameter	Test Conditions	Values			Units
			Min.	Typ.	Max.	
$R_g$	Gate resistance	$f = 1.0\text{MHz}$	--	2	--	$\Omega$
$C_{iss}$	Input Capacitance	$V_{GS} = 0V$ $V_{DS} = 25V$ $F = 1.0\text{MHz}$	--	1320	--	PF
$C_{oss}$	Output Capacitance		--	450	--	
$C_{rss}$	Reverse Transfer Capacitance		--	130	--	

Switching Characteristics						
Symbol	Parameter	Test Conditions	Values			Units
			Min.	Typ.	Max.	
$t_{d(ON)}$	Turn-on Delay Time	$I_D = 18A$ $V_{DD} = 100V$ $V_{GS} = 10V$ $R_G = 20\Omega$	--	15	--	ns
$T_r$	Rise Time		--	52	--	
$t_{d(OFF)}$	Turn-Off Delay Time		--	46	--	
$t_f$	Fall Time		--	37	--	
$Q_g$	Total Gate Charge	$I_D = 18A$ $V_{DD} = 160V$ $V_{GS} = 10V$	--	23	--	nC
$Q_{gs}$	Gate to Source Charge		--	8	--	
$Q_{gd}$	Gate to Drain ("Miller") Charge		--	6	--	

Source-Drain Diode Characteristics						
Symbol	Parameter	Test Conditions	Values			Units
			Min	Typ.	Max.	
$I_s$	Continuous Source Current (Body Diode)	$T_c=25^\circ C$	--	--	18	A
$I_{SM}$	Maximum Pulsed Current (Body Diode)		--	--	72	A

V <sub>SD</sub>	Diode Forward Voltage	I <sub>S</sub> =18A, V <sub>GS</sub> =0V(Note4)	--	--	1.2	V
T <sub>rr</sub>	Reverse Recovery Time	I <sub>S</sub> =18A, T <sub>J</sub> = 25°C	--	350	--	ns
Q <sub>rr</sub>	Reverse Recovery Charge	dI <sub>F</sub> /dt=100A/us, V <sub>GS</sub> =0V	--	3600	--	nC

Note1: Pulse width limited by maximum junction temperature

Note2: L=2.7mH, V<sub>Ds</sub>=50V, Start T<sub>J</sub>=25°C

Note3: I<sub>SD</sub> =18A, di/dt ≤100A/us, V<sub>DD</sub>≤BV<sub>DS</sub>, Start T<sub>J</sub>=25°C

Note4: Pulse width t<sub>p</sub>≤300μs, δ≤2%

Characteristics Curves

Figure 1a Safe Operating Area (No FullPAK)

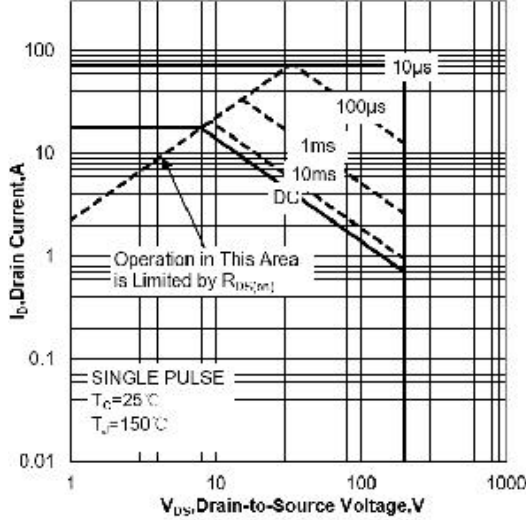

Figure 1b Safe Operating Area (FullPAK)

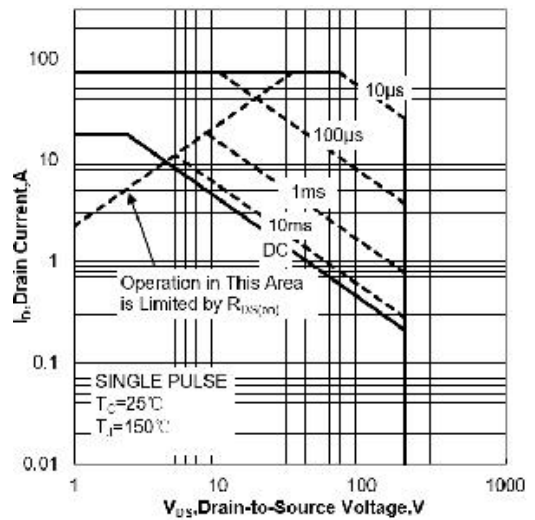

Figure 2a Power Dissipation (No FullPAK)

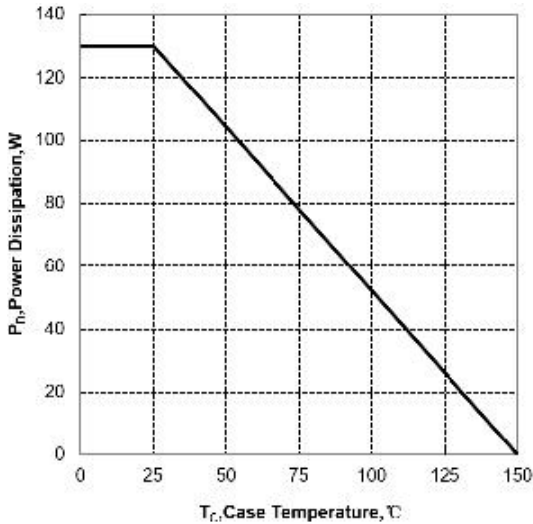

Figure 2b Power Dissipation (FullPAK)

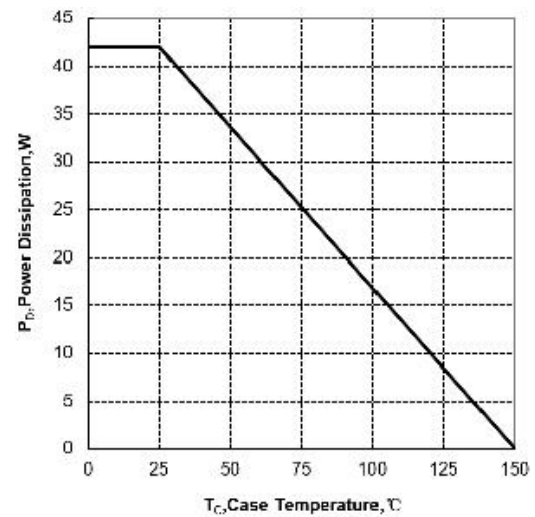

Figure 3a Max Thermal Impedance (No FullPAK)

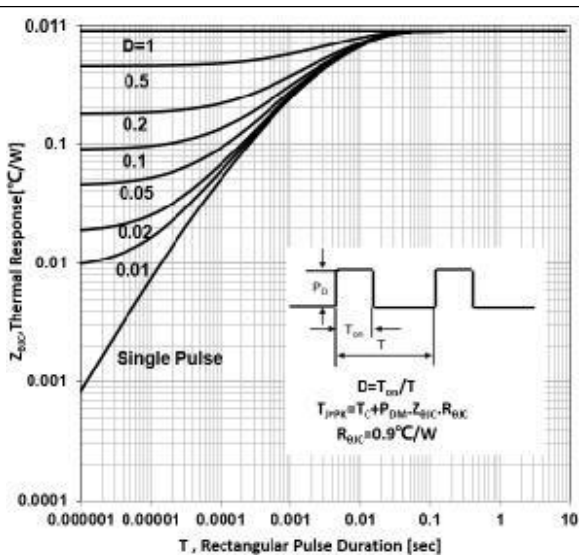

Figure 3b Max Thermal Impedance (FullPAK)

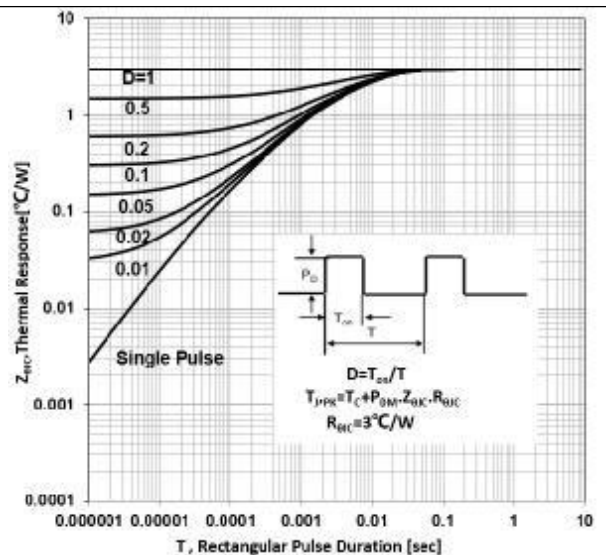

Figure 4 Typical Output Characteristics

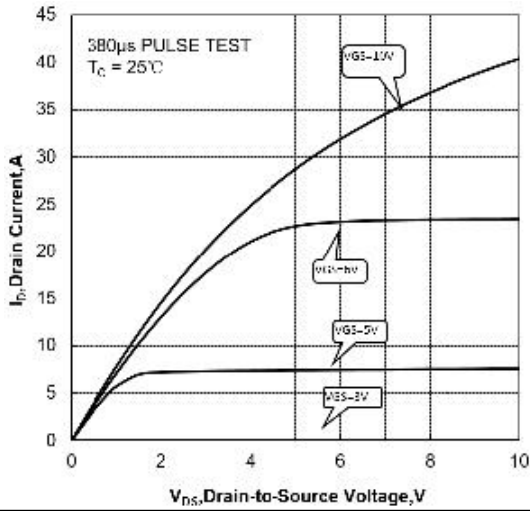

Figure 5 Typical Transfer Characteristics

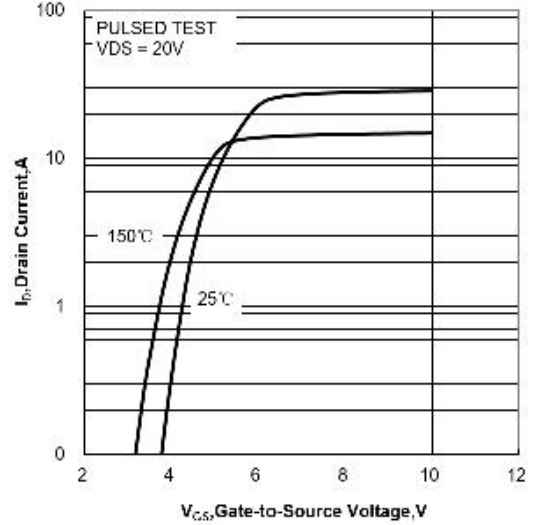

Figure 6 Typical Drain to Source ON Resistance vs Drain Current

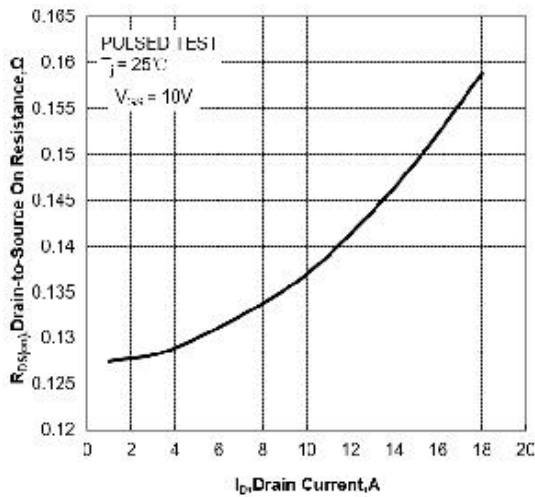

Figure 7 Typical Drain to Source on Resistance vs Junction Temperature

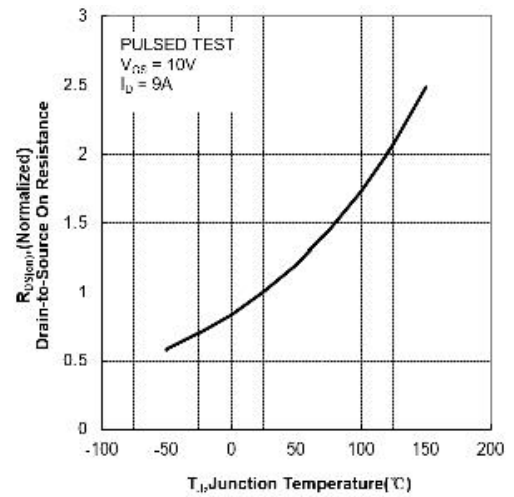

Figure 8 Typical Theshold Voltage vs Junction Temperature

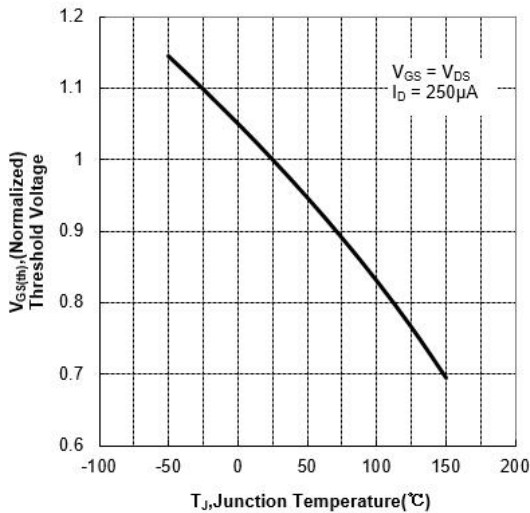

Figure 9 Typical Breakdown Voltage vs Junction Temperature

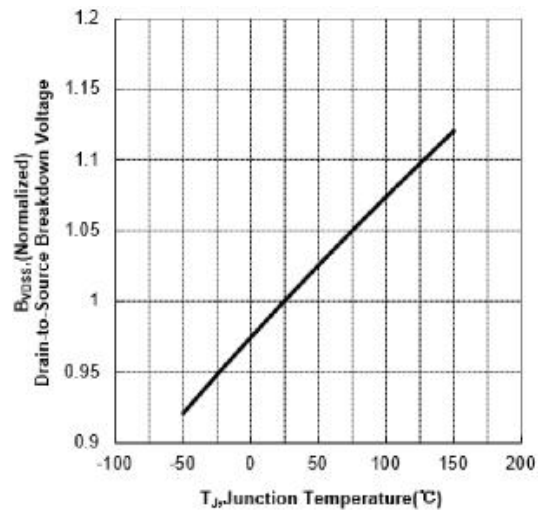

Figure 10 Capacitance Characteristics

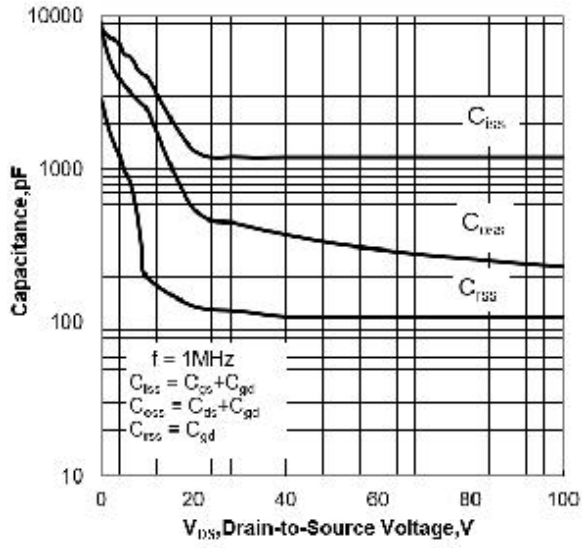
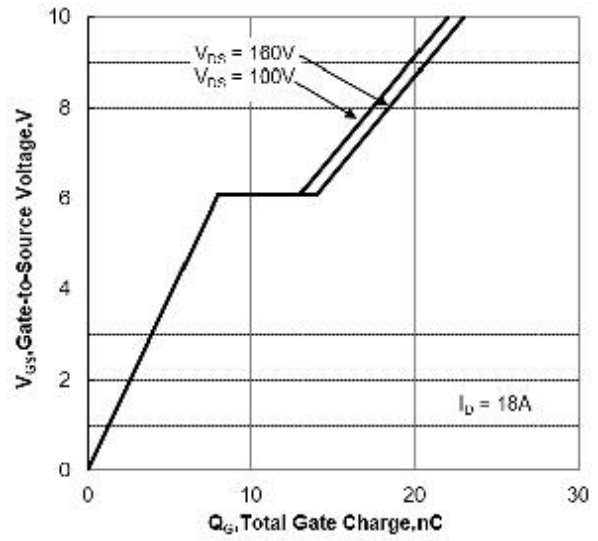

Figure 11 Gate Charge Characteristics





Test Circuit and Waveform

Figure 12 Gate Charge Test Circuit

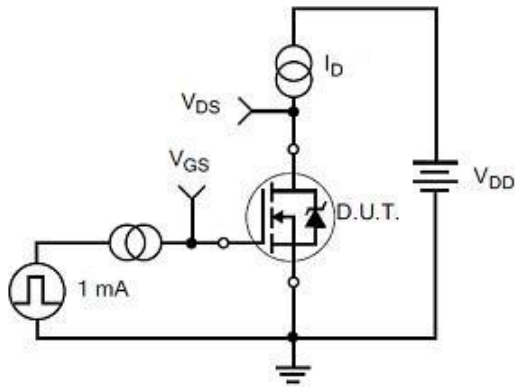

Figure 13 Gate Charge Waveforms

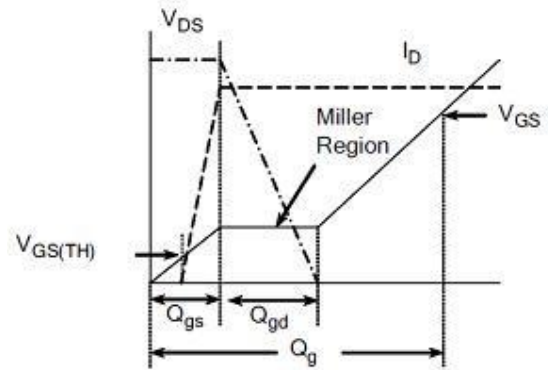

Figure 14 Resistive Switching Test Circuit

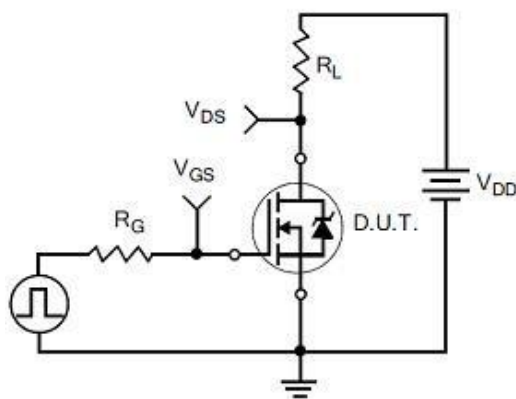

Figure 15 Resistive Switching Waveforms

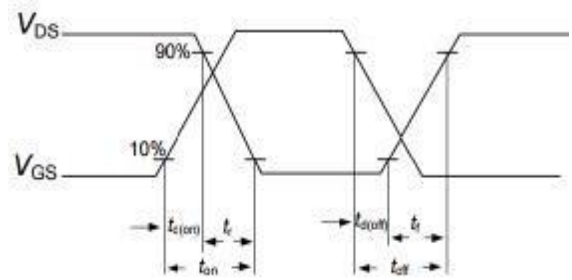

Figure 16 Diode Reverse Recovery Test Circuit

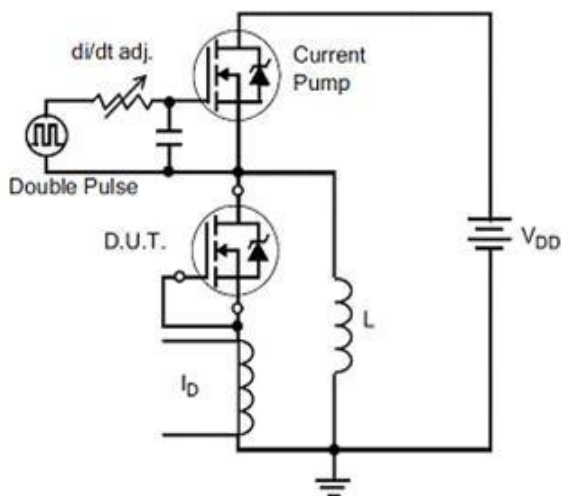

Figure 17 Diode Reverse Recovery Waveform

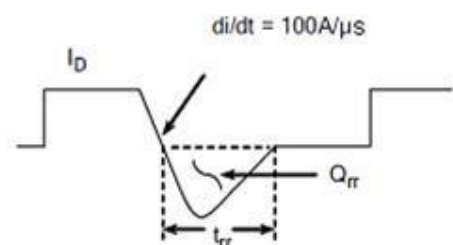
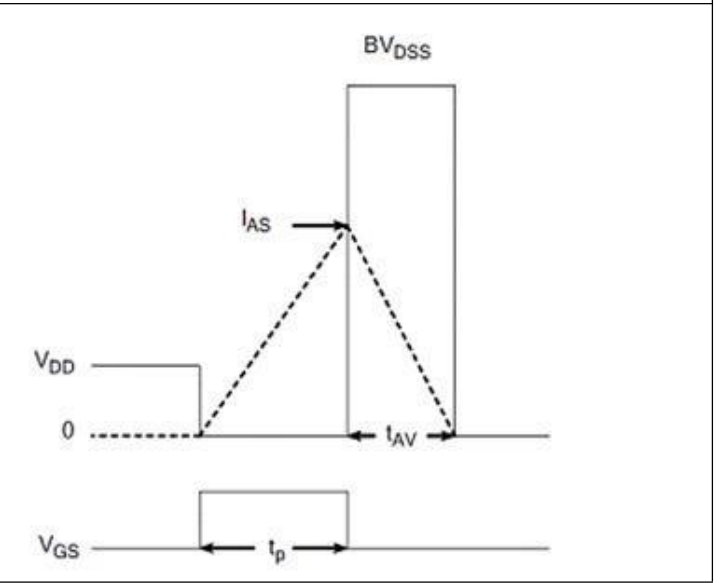
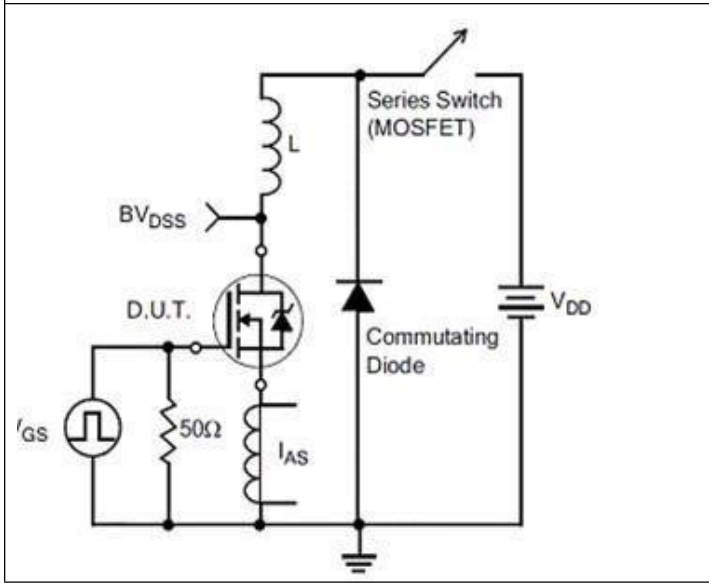

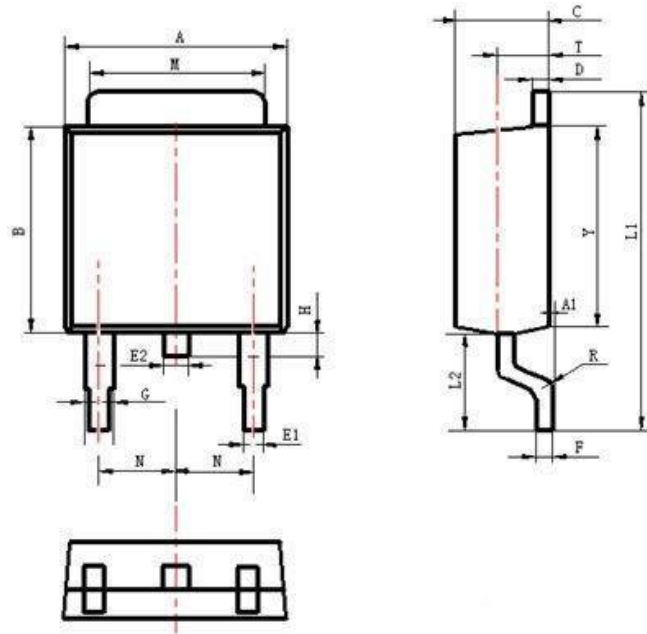

Figure 18 Unclamped Inductive Switching Test Circuit

Figure 19 Unclamped Inductive Switching Waveform



Package Description



Items	Values(mm)	
	MIN	MAX
A	6.30	6.90
A1	0	0.13
B	5.70	6.30
C	2.10	2.50
D	0.30	0.60
E1	0.60	0.90
E2	0.70	1.00
F	0.30	0.60
G	0.70	1.20
L1	9.60	10.50
L2	2.70	3.10
H	0.60	1.00
M	5.10	5.50
N	2.09	2.49
R	0.3	
T	1.40	1.60
Y	5.10	6.30

TO-252 Package



**NOTE:**

1. Exceeding the maximum ratings of the device in performance may cause damage to the device, even the permanent failure, which may affect the dependability of the machine. Please do not exceed the absolute maximum ratings of the device when circuit designing.
2. When installing the heat sink, please pay attention to the torsional moment and the smoothness of the heat sink.
3. MOSFETs is the device which is sensitive to the static electricity, it is necessary to protect the device from being damaged by the static electricity when using it.
4. Shenzhen Minos reserves the right to make changes in this specification sheet and is subject to change without prior notice.

**CONTACT:**

**深圳市迈诺斯科技有限公司（总部）**

地址：深圳市福田区华富街道田面社区深南中路4026号田面城市大厦22B-22C

邮编：518025

电话：0755-83273777

## X-ON Electronics

Largest Supplier of Electrical and Electronic Components

*Click to view similar products for [MOSFET](#) category:*

*Click to view products by [Minos](#) manufacturer:*

Other Similar products are found below :

[IRFD120](#) [IRFY240C](#) [JANTX2N5237](#) [2SK2267\(Q\)](#) [BUK455-60A/B](#) [MIC4420CM-TR](#) [VN1206L](#) [NDP4060](#) [SI4482DY](#)  
[IPS70R2K0CEAKMA1](#) [SQD23N06-31L-GE3](#) [TK16J60W,S1VQ\(O](#) [2SK2614\(TE16L1,Q\)](#) [DMN1017UCP3-7](#) [EFC2J004NUZTDG](#)  
[DMN1053UCP4-7](#) [SQJ469EP-T1-GE3](#) [NTE2384](#) [DMC2700UDMQ-7](#) [DMN2080UCB4-7](#) [DMN61D9UWQ-13](#) [US6M2GTR](#)  
[DMN31D5UDJ-7](#) [DMP22D4UFO-7B](#) [DMN1006UCA6-7](#) [DMN16M9UCA6-7](#) [STF5N65M6](#) [IRF40H233XTMA1](#) [STU5N65M6](#)  
[DMN6022SSD-13](#) [DMN13M9UCA6-7](#) [DMTH10H4M6SPS-13](#) [DMN2990UFB-7B](#) [IPB80P04P405ATMA2](#) [2N7002W-G](#) [MCAC30N06Y-](#)  
[TP](#) [MCQ7328-TP](#) [NTMC083NP10M5L](#) [NVMFS2D3P04M8LT1G](#) [BXP7N65D](#) [BXP4N65F](#) [AOL1454G](#) [WMJ80N60C4](#) [BXP2N20L](#)  
[BXP2N65D](#) [BXT1150N10J](#) [BXT1700P06M](#) [TSM60NB380CP](#) [ROG](#) [RQ7L055BGTCR](#) [DMNH15H110SK3-13](#)