

1. Description

MDT9N20 the silicon N-channel Enhanced MOSFETs, is obtained by advanced MOSFET technology which reduce the conduction loss, improve switching performance and enhance the avalanche energy. The transistor is suitable device for SMPS, high speed switching and general purpose applications.

KEY CHARACTERISTICS

Parameter	Value	Unit
V_{DS}	200	V
I_D	9	A
$R_{DS(ON).Typ}$	0.27	Ω

FEATURES

- | Fast Switching
- | Low C_{rss}
- | 100% avalanche tested
- | Improved dv/dt capability
- | RoHS product

APPLICATIONS

- | High frequency switching mode power supply

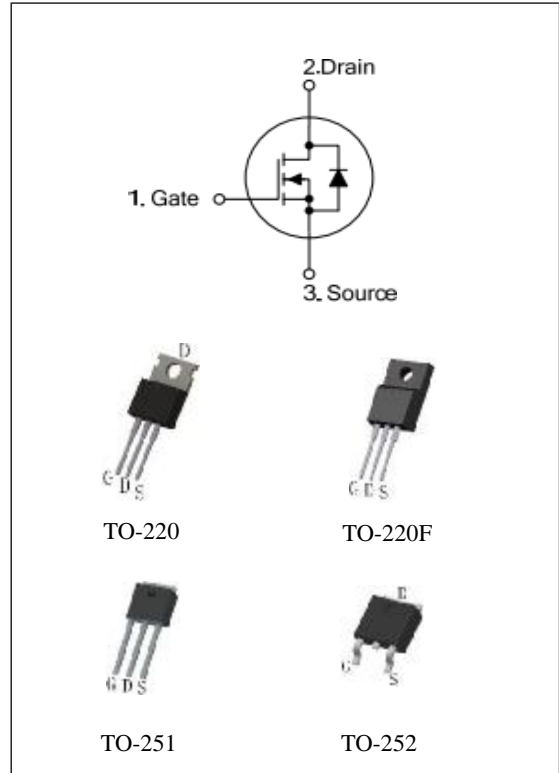

ORDERING INFORMATION

Ordering Codes	Package	Product Code	Packing
MP9N20	TO-220	9N20	Tube
MPF9N20	TO-220F		Tube
MDP9N20	TO-251		Tube
MDT9N20	TO-252		Reel

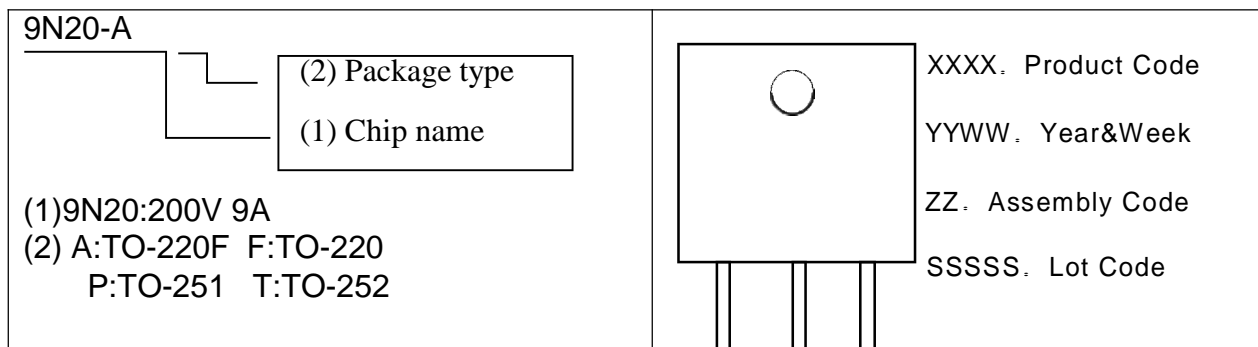

2. ABSOLUTE RATINGS

at $T_C = 25^\circ\text{C}$, unless otherwise specified

Symbol	Parameter	Rating	Units
V_{DSS}	Drain-to-Source Voltage	200	V
I_D	Continuous Drain Current	9	A
	Continuous Drain Current $T_C = 100^\circ\text{C}$	5.5	A
I_{DM}	Pulsed Drain Current(Note1)	36	A
V_{GS}	Gate-to-Source Voltage	± 30	V
E_{AS}	Single Pulse Avalanche Energy(Note2)	200	mJ
dv/dt	Peak Diode Recovery dv/dt (Note3)	5.0	V/ns
P_D	Power Dissipation TO-220, TO-251, TO-252	75	W
	Derating Factor above 25°C	0.6	W/ $^\circ\text{C}$
P_D	Power Dissipation TO-220F	30	W
	Derating Factor above 25°C	0.24	W/ $^\circ\text{C}$
T_J, T_{stg}	Operating Junction and Storage Temperature Range	150, -55 to 150	$^\circ\text{C}$
T_L	Maximum Temperature for Soldering	300	$^\circ\text{C}$

3. Thermal characteristics

Thermal characteristics (No FullPAK) TO-220\TO-251\TO-252

Symbol	Parameter	RATINGS	Units
$R_{\theta JC}$	Junction-to-Case	1.67	$^\circ\text{C}/\text{W}$
$R_{\theta JA}$	Junction-to-Ambient	62.5	$^\circ\text{C}/\text{W}$

Thermal characteristics (FullPAK) TO-220F

Symbol	Parameter	RATINGS	Units
$R_{\theta JC}$	Junction-to-Case	4.17	$^\circ\text{C}/\text{W}$
$R_{\theta JA}$	Junction-to-Ambient	62.5	$^\circ\text{C}/\text{W}$

4. Electrical Characteristics

at $T_C = 25^\circ\text{C}$, unless otherwise specified

OFF Characteristics						
Symbol	Parameter	Test Conditions	Values			Units
			Min.	Typ.	Max.	
V_{DSS}	Drain to Source Breakdown Voltage	$V_{GS}=0V$, $I_D=250\mu A$	200	--	--	V
$\Delta BV_{DSS}/\Delta T_J$	Bvdss Temperature Coefficient	$I_D=250\mu A$, Reference 25°C	--	0.25	--	V/ $^\circ\text{C}$
I_{DSS}	Drain to Source Leakage Current	$V_{DS} = 200V$, $V_{GS} = 0V$, $T_J = 25^\circ\text{C}$	--	--	1	μA
		$V_{DS} = 160V$, $V_{GS} = 0V$, $T_J = 125^\circ\text{C}$	--	--	100	μA
$I_{GSS(F)}$	Gate to Source Forward Leakage	$V_{GS} = +30V$	--	--	100	nA
$I_{GSS(R)}$	Gate to Source Reverse Leakage	$V_{GS} = -30V$	--	--	100	nA

ON Characteristics						
Symbol	Parameter	Test Conditions	Values			Units
			Min.	Typ.	Max.	
$R_{DS(ON)}$	Drain-to-Source On-Resistance	$V_{GS}=10V$, $I_D=4A$ (Note4)	--	0.27	0.32	Ω
$V_{GS(TH)}$	Gate Threshold Voltage	$V_{DS} = V_{GS}$, $I_D = 250\mu A$ (Note4)	2.0	--	4.0	V

Dynamic Characteristics						
Symbol	Parameter	Test Conditions	Values			Units
			Min.	Typ.	Max.	
R_g	Gate resistance	$f = 1.0\text{MHz}$	--	3.5	--	Ω
C_{iss}	Input Capacitance	$V_{GS} = 0V$ $V_{DS} = 25V$ $f = 1.0\text{MHz}$	--	550	--	PF
C_{oss}	Output Capacitance		--	90	--	
C_{rss}	Reverse Transfer Capacitance		--	8.6	--	

Switching Characteristics						
Symbol	Parameter	Test Conditions	Values			Units
			Min.	Typ.	Max.	
$t_{d(ON)}$	Turn-on Delay Time	ID =9A VDD = 100V VGS = 10V RG =5Ω	--	10	--	ns
t_r	Rise Time		--	5	--	
$t_{d(OFF)}$	Turn-Off Delay Time		--	20	--	
t_f	Fall Time		--	7	--	
Q_g	Total Gate Charge	ID =9A VDD =160V VGS = 10V	--	12	--	nC
Q_{gs}	Gate to Source Charge		--	3	--	
Q_{gd}	Gate to Drain ("Miller")Charge		--	6	--	

Source-Drain Diode Characteristics						
Symbol	Parameter	Test Conditions	Values			Units
			Min.	Typ.	Max.	
I_S	Continuous Source Current (Body Diode)	TC=25 °C	--	--	9	A
I_{SM}	Maximum Pulsed Current (Body Diode)		--	--	36	A
V_{SD}	Diode Forward Voltage	IS=9A, VGS=0V(Note4)	--	--	1.2	V
T_{rr}	Reverse Recovery Time	IS=9A, Tj = 25°C dIF/dt=100A/us, VGS=0V	--	110	--	ns
Q_{rr}	Reverse Recovery Charge		--	465	--	nC

Note1: Pulse width limited by maximum junction temperature

Note2: L=20mH, VDS=50V, Start TJ=25°C

Note3: ISD =9A, di/dt ≤100A/us, VDD≤BVDS, Start TJ=25°C

Note4: Pulse width tp≤300μs, δ≤2%

5. Characteristics Curves

Figure 1a Safe Operating Area (No FullPAK)

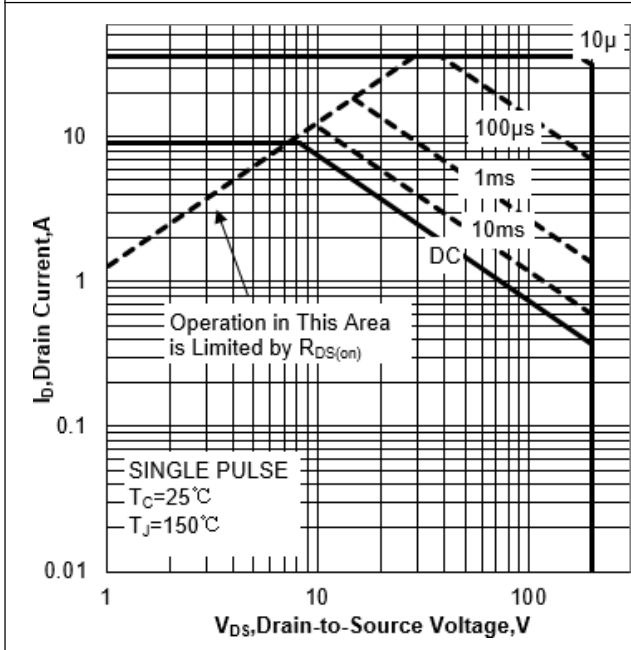

Figure 1b Safe Operating Area (FullPAK)

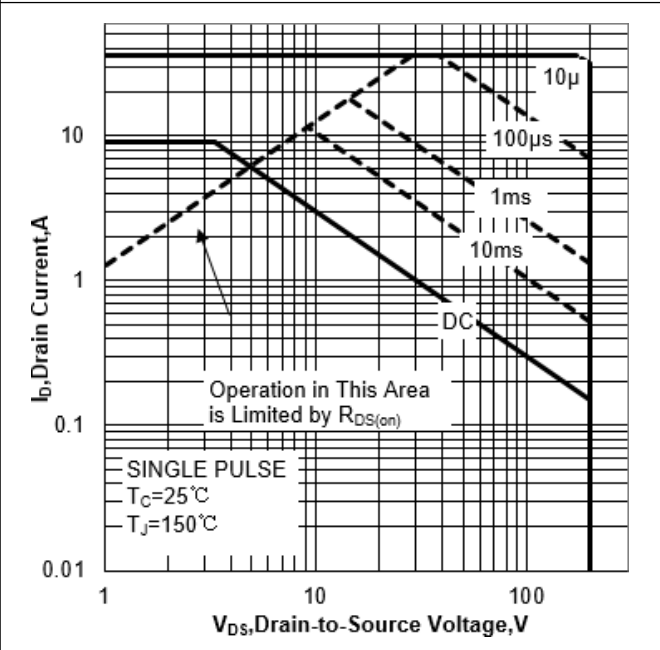

Figure 2a Power Dissipation (No FullPAK)

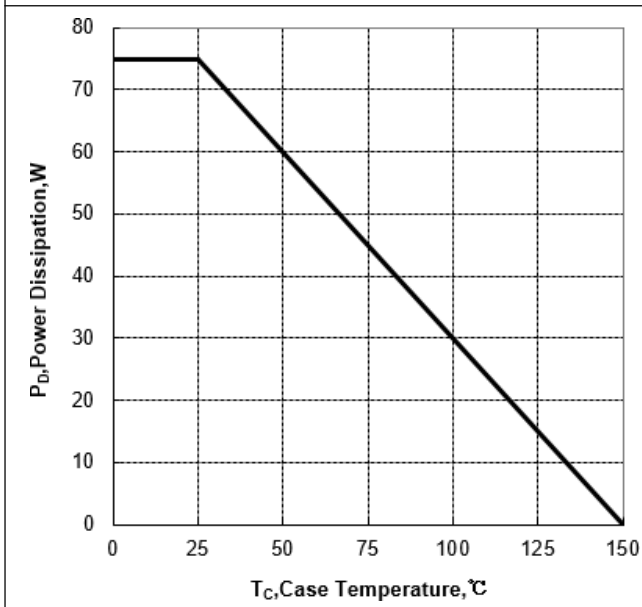

Figure 2b Power Dissipation (FullPAK)

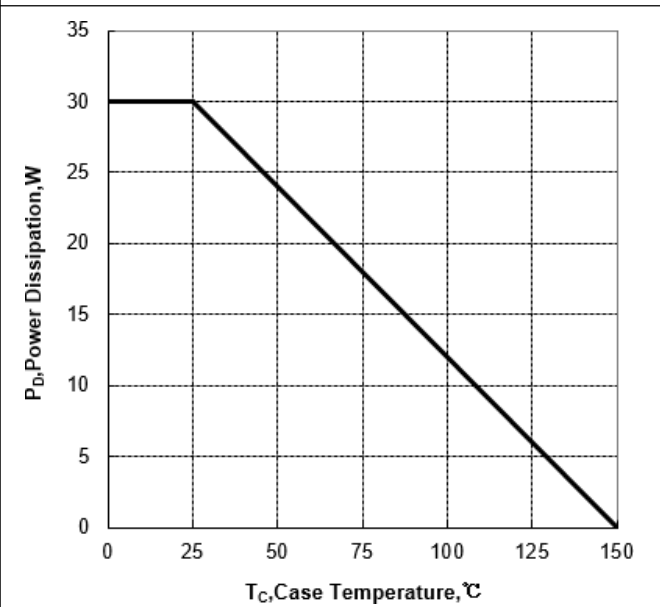

Figure 3a Max Thermal Impedance (No FullPAK)

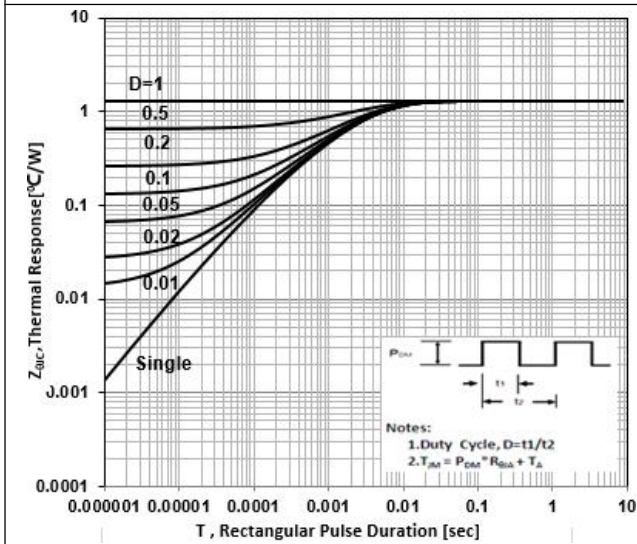

Figure 3b Max Thermal Impedance (FullPAK)

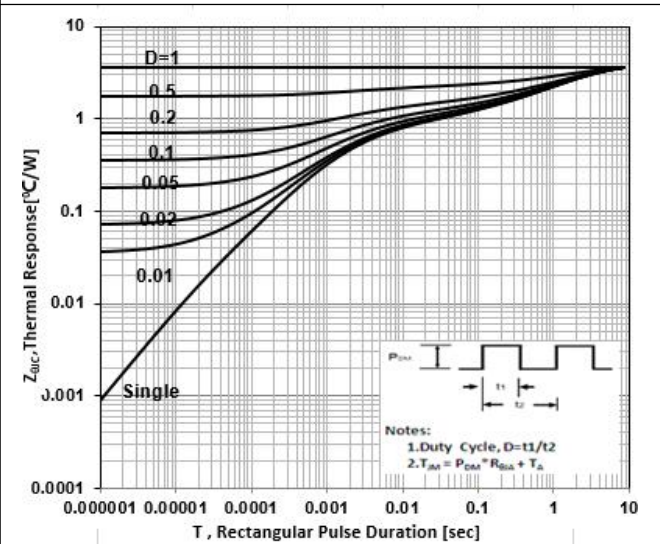

Figure 4 Typical Output Characteristics

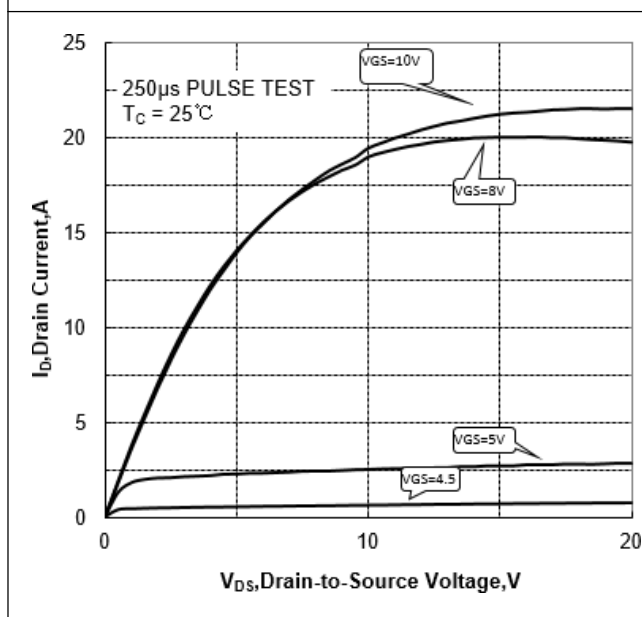

Figure 5 Typical Transfer Characteristics

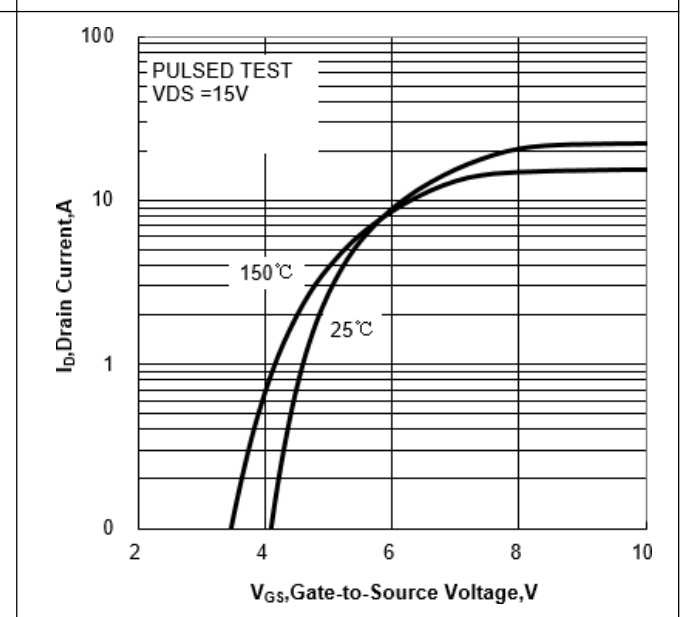

Figure 6 Typical Drain to Source ON Resistance vs Drain Current

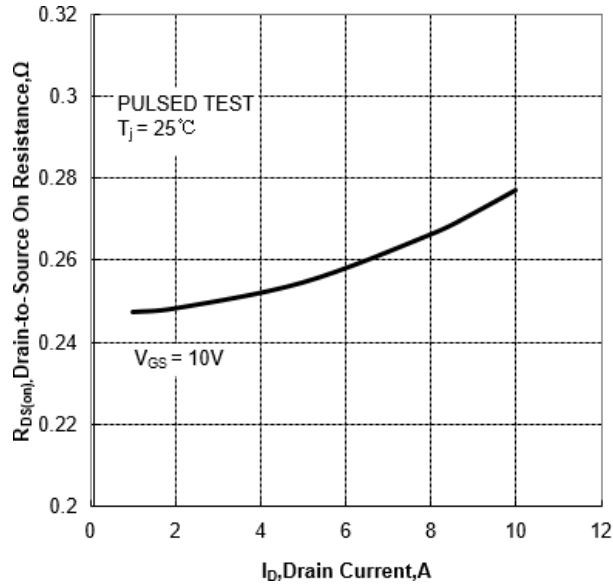

Figure 7 Typical Drain to Source on Resistance vs Junction Temperature

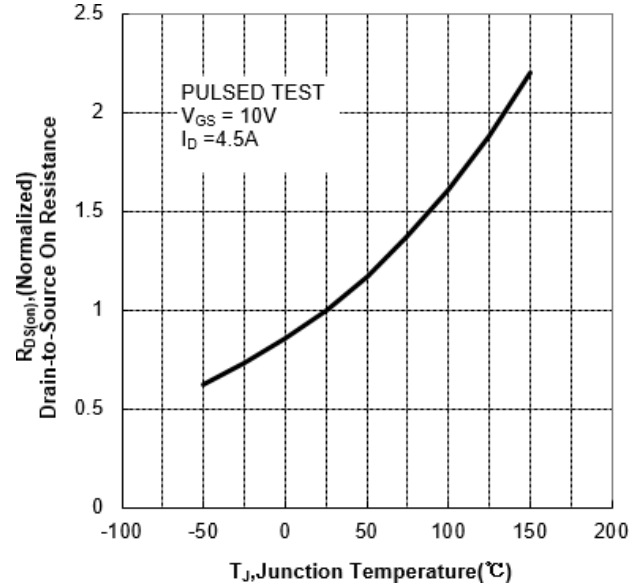

Figure 8 Typical Theshold Voltage vs Junction Temperature

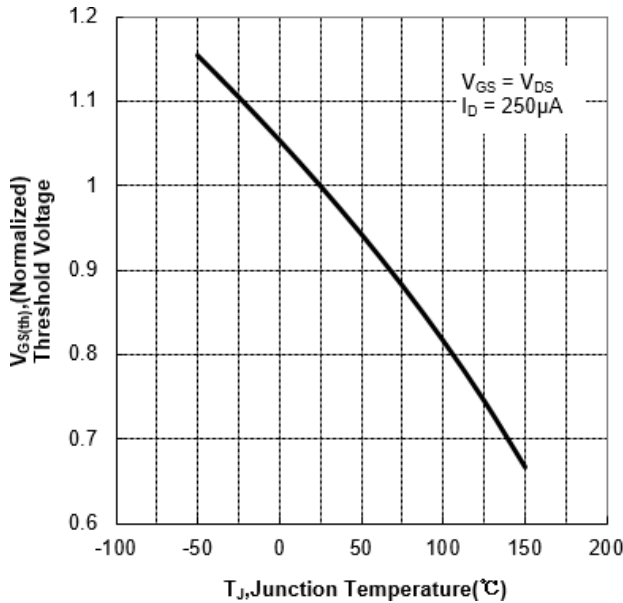

Figure 9 Typical Breakdown Voltage vs Junction Temperature

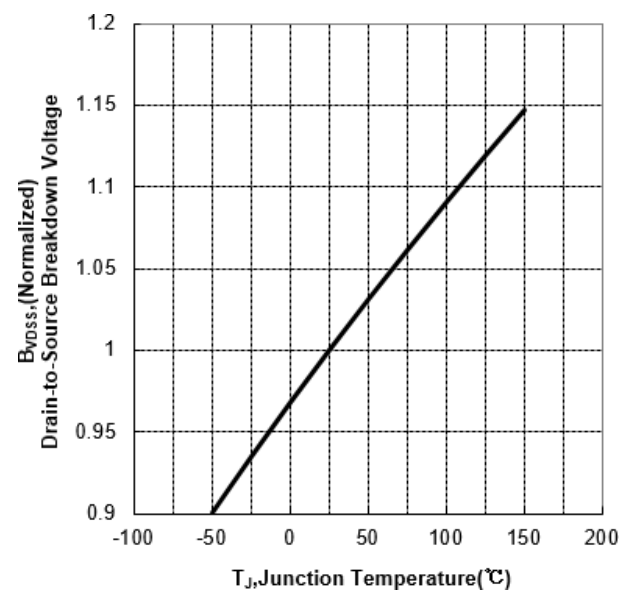

Figure 10 Typical Theshold Voltage vs Junction Temperature

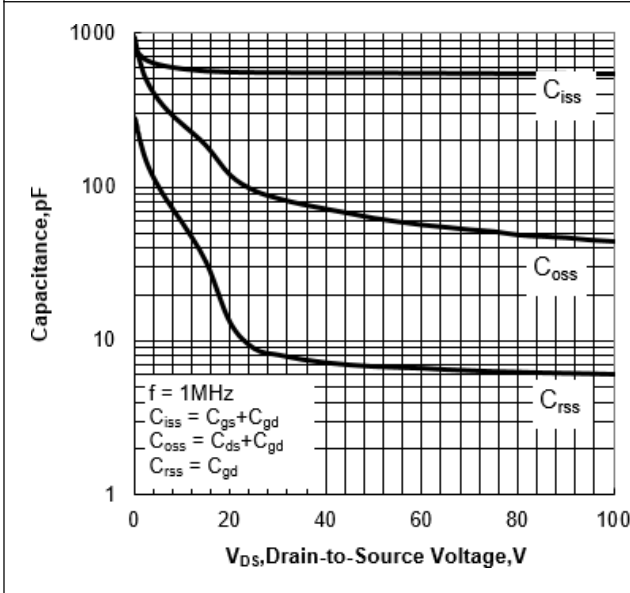
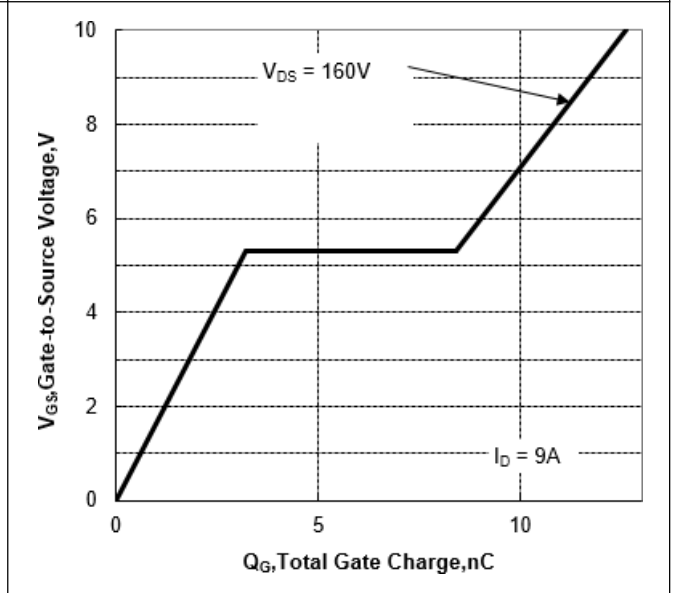

Figure 11 Typical Breakdown Voltage vs Junction Temperature



6. Test Circuit and Waveform

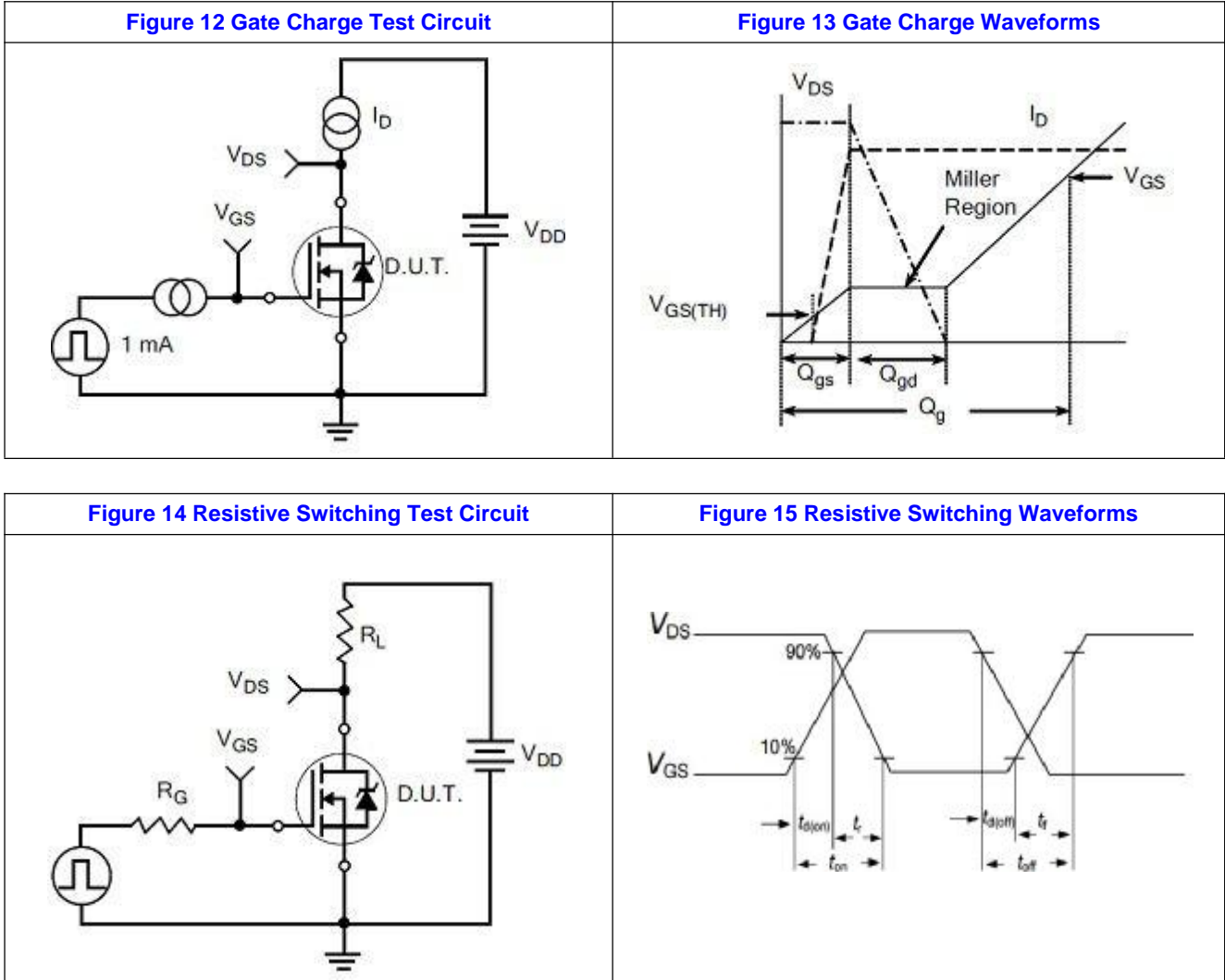

Figure 16 Diode Reverse Recovery Test Circuit

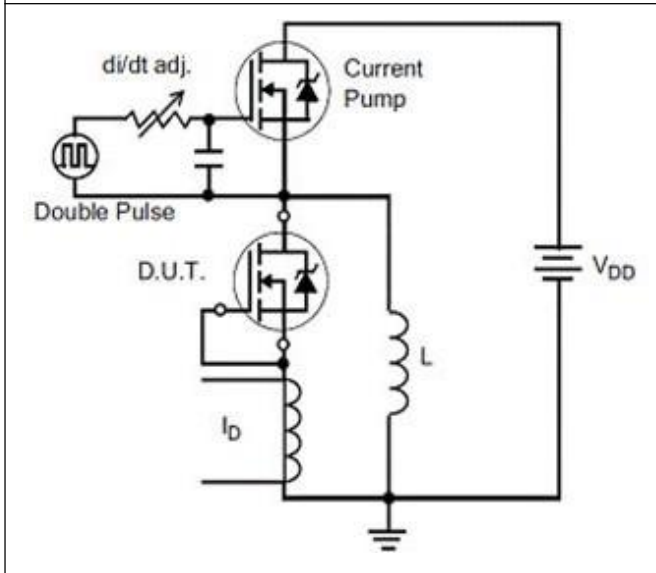

Figure 17 Diode Reverse Recovery Waveform

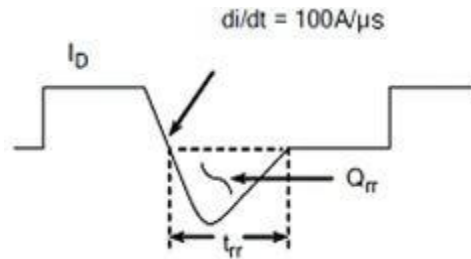

Figure 18 Unclamped Inductive Switching Test Circuit

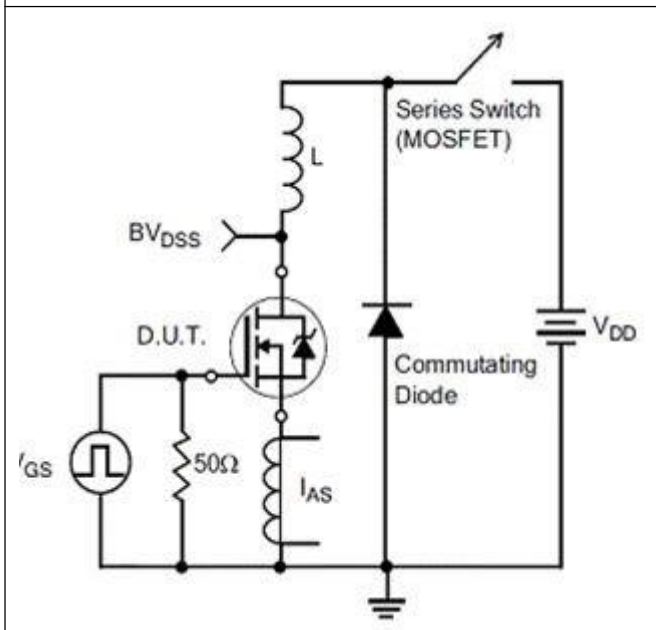
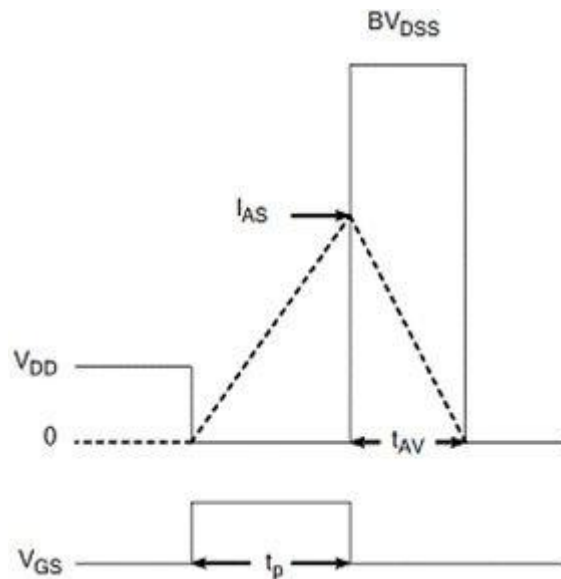
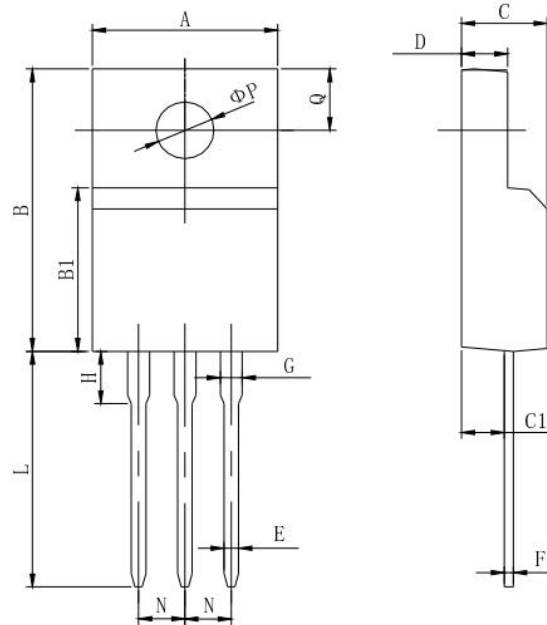

Figure 19 Unclamped Inductive Switching Waveform



7. Package Description



Items	Values(mm)	
	MIN	MAX
A	9.60	10.4
B	15.4	16.2
B1	8.90	9.50
C	4.30	4.90
C1	2.10	3.00
D	2.40	3.00
E	0.60	1.00
F	0.30	0.60
G	1.12	1.42
H	3.40	3.80
	1.60	2.90
L	12.0	14.0
N	2.34	2.74
Q	3.15	3.55
±P	2.90	3.30

TO-220F Package

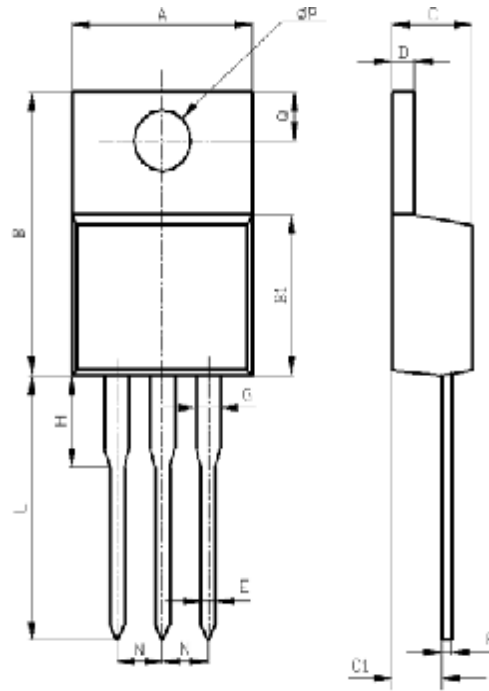

Items	Values(mm)	
	MIN	MAX
A	9.60	10.6
B	15.0	16.0
B1	8.90	9.50
C	4.30	4.80
C1	2.30	3.10
D	1.20	1.40
E	0.70	0.90
F	0.30	0.60
G	1.17	1.37
H	2.70	3.80
L	12.6	14.8
N	2.34	2.74
Q	2.40	3.00
ΦP	3.50	3.90

TO-220 Package

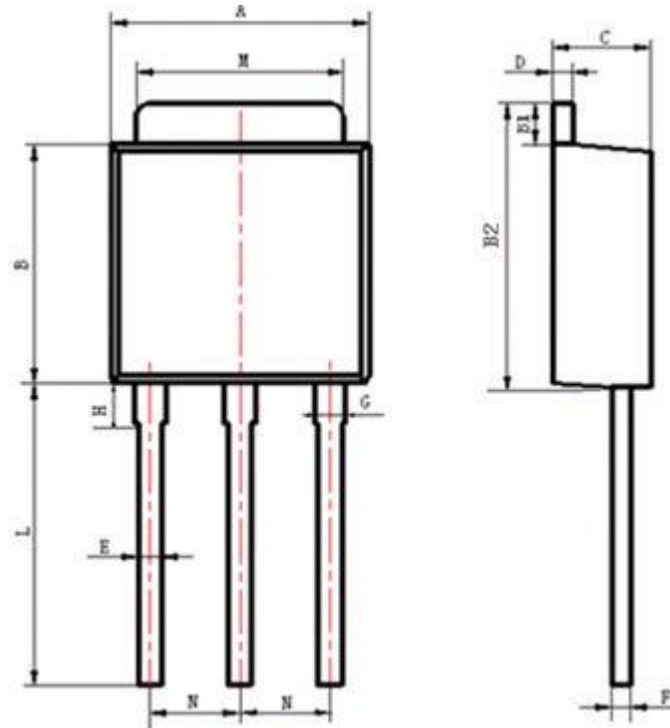

Items	Values(mm)	
	MIN	MAX
A	6.30	6.90
B	5.70	6.30
B1	1.00	1.20
B2	6.80	7.40
C	2.10	2.50
D	0.30	0.60
E	0.50	0.70
F	0.30	0.60
G	0.70	1.00
H	1.60	2.40
L*	3.9	4.3
M	5.10	5.50
N	2.09	2.49

TO-251 Package

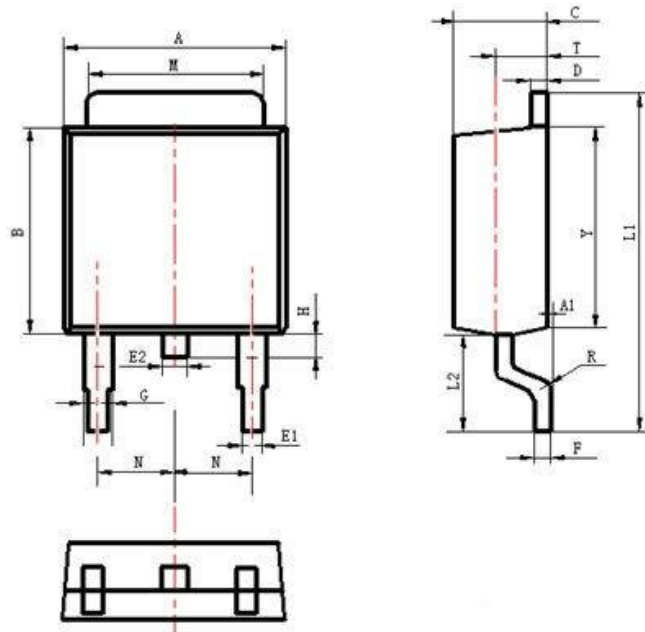

Items	Values(mm)	
	MIN	MAX
A	6.30	6.90
A1	0	0.13
B	5.70	6.30
C	2.10	2.50
D	0.30	0.60
E1	0.60	0.90
E2	0.70	1.00
F	0.30	0.60
G	0.70	1.20
L1	9.60	10.50
L2	2.70	3.10
H	0.60	1.00
M	5.10	5.50
N	2.09	2.49
R	0.3	
T	1.40	1.60
Y	5.10	6.30

TO-252 Package

X-ON Electronics

Largest Supplier of Electrical and Electronic Components

Click to view similar products for [MOSFET](#) category:

Click to view products by [Minos](#) manufacturer:

Other Similar products are found below :

[IRFD120](#) [IRFY240C](#) [JANTX2N5237](#) [2SK2267\(Q\)](#) [BUK455-60A/B](#) [MIC4420CM-TR](#) [VN1206L](#) [NDP4060](#) [SI4482DY](#)
[IPS70R2K0CEAKMA1](#) [SQD23N06-31L-GE3](#) [TK16J60W,S1VQ\(O](#) [2SK2614\(TE16L1,Q\)](#) [DMN1017UCP3-7](#) [EFC2J004NUZTDG](#)
[DMN1053UCP4-7](#) [SQJ469EP-T1-GE3](#) [NTE2384](#) [DMC2700UDMQ-7](#) [DMN2080UCB4-7](#) [DMN61D9UWQ-13](#) [US6M2GTR](#)
[DMN31D5UDJ-7](#) [DMP22D4UFO-7B](#) [DMN1006UCA6-7](#) [DMN16M9UCA6-7](#) [STF5N65M6](#) [IRF40H233XTMA1](#) [STU5N65M6](#)
[DMN6022SSD-13](#) [DMN13M9UCA6-7](#) [DMTH10H4M6SPS-13](#) [DMN2990UFB-7B](#) [IPB80P04P405ATMA2](#) [2N7002W-G](#) [MCAC30N06Y-](#)
[TP](#) [MCQ7328-TP](#) [NTMC083NP10M5L](#) [NVMFS2D3P04M8LT1G](#) [BXP7N65D](#) [BXP4N65F](#) [AOL1454G](#) [WMJ80N60C4](#) [BXP2N20L](#)
[BXP2N65D](#) [BXT1150N10J](#) [BXT1700P06M](#) [TSM60NB380CP](#) [ROG](#) [RQ7L055BGTCR](#) [DMNH15H110SK3-13](#)