

1. Description

MLG50T65FUK is obtained by advanced Trench Field Stop (T-FS) technology which is characteristic with low $V_{CE(sat)}$, optimized switching performance and low gate charge Q_g . The IGBT is suitable device for welding, UPS, and high switching frequency applications.

KEY CHARACTERISTICS

| Parameter | Value | Unit |
|-------------------|-------|------|
| V_{CES} | 650 | V |
| I_C | 50 | A |
| $V_{CE(sat).typ}$ | 1.6 | V |

FEATURES

- | Fast Switching
- | Low $V_{CE(sat)}$
- | Positive temperature coefficient
- | Fast recovery anti-parallel diode
- | RoHS product

APPLICATIONS

- | Welding converters
- | UPS
- | Boost Chopper
- | Air condition

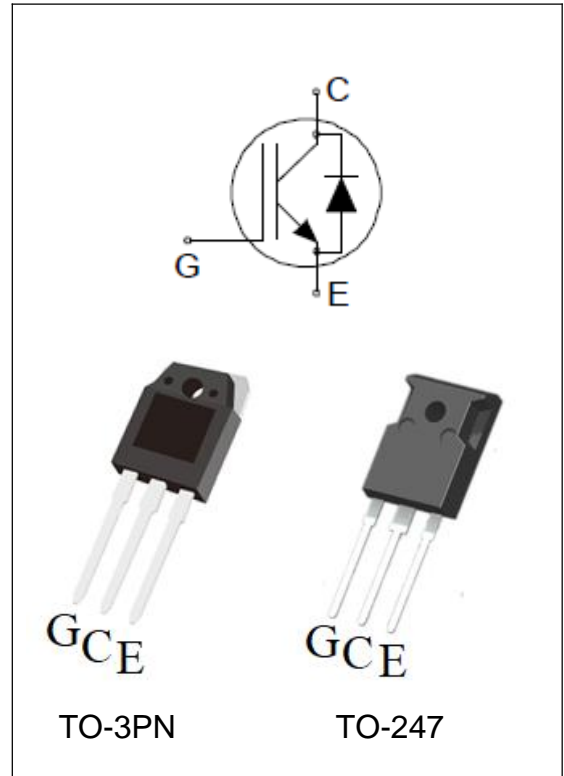

ORDERING INFORMATION

| Ordering Codes | Package | Product Code | Packing |
|----------------|---------|--------------|---------|
| MLG50T65FUK-W | TO-3PN | G50T65 | Tube |
| MLG50T65FUK-F | TO-247 | G50T65 | Tube |

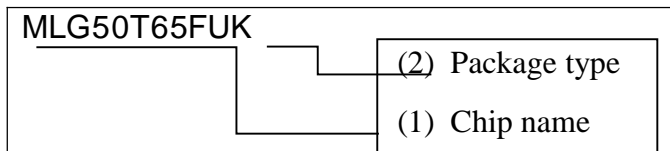
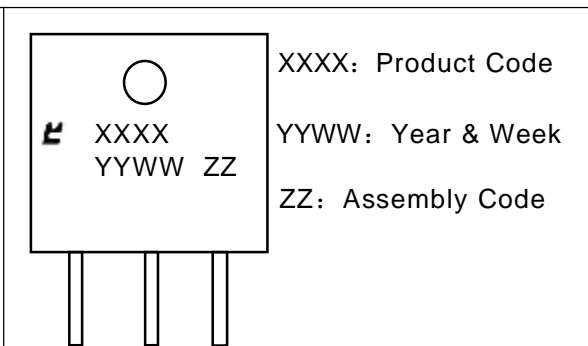
| | |
|---|--|
| <p>MLG50T65FUK</p>  <p>(1) MLG50T65FUK: 650V 50A (2) W:TO-3PN F:TO-247</p> |  <p>XXXX: Product Code YYWW: Year & Week ZZ: Assembly Code</p> |
|---|--|



2. ABSOLUTE RATINGS

| Symbol | Parameter | Values | Units |
|---------------------|--|-------------------|-------------|
| V_{CES} | Collector-Emitter Voltage | 650 | V |
| I_C | Collector Current @ $T_C=25^{\circ}C$ | 100 | A |
| | Collector Current @ $T_C=100^{\circ}C$ | 50 | A |
| I_{CM} | Pulsed Collector Current, tp limited by T_{Jmax} | 200 | A |
| I_F | Diode Continuous Forward Current @ $T_C=25^{\circ}C$ | 50 | A |
| | Diode Continuous Forward Current @ $T_C=100^{\circ}C$ | 25 | A |
| I_{FM} | Diode Maximum Forward Current, limited by T_{Jmax} | 200 | A |
| V_{GES} | Gate-Emitter Voltage | ± 30 | V |
| t_{SC} | Short circuit withstand time $V_{GE}=15V, V_{CC}\leq 400V$, Allowed number of short circuits<1000, Times between short circuits: $\geq 1.0s, T_J \leq 175^{\circ}C$ | 8.0 | μs |
| P_D | Power Dissipation @ $T_C=25^{\circ}C$ | 300 | W |
| T_{Jmax}, T_{stg} | Operating Junction and Storage Temperature Range | 175, -55 to 175 | $^{\circ}C$ |
| T_L | Maximum Temperature for Soldering | 260 | $^{\circ}C$ |

3. Thermal characteristics

| Symbol | Parameter | Values | Units |
|-----------------|--------------------------|--------|---------------|
| $R_{\theta JC}$ | Junction-to-Case (IGBT) | 0.5 | $^{\circ}C/W$ |
| $R_{\theta JC}$ | Junction-to-Case (Diode) | 0.65 | $^{\circ}C/W$ |
| $R_{\theta JA}$ | Junction-to-Ambient | 40 | $^{\circ}C/W$ |

4. Electrical Characteristics

at $T_C = 25^{\circ}C$, unless otherwise specified

Static Characteristics

| Symbol | Parameter | Test Conditions | Values | | | Units |
|---------------|--------------------------------------|-------------------------------|--------|------|------|-------|
| | | | Min. | Typ. | Max. | |
| V_{CES} | Collector-Emitter Breakdown Voltage | $V_{GE} = 0V, I_C = 250\mu A$ | 650 | -- | -- | V |
| $V_{CE(sat)}$ | Collector-Emitter Saturation Voltage | $V_{GE} = 15V, I_C = 50A$ | -- | 1.60 | 2.00 | V |
| | | $T_J=25^{\circ}C$ | -- | 1.85 | -- | |
| | | $T_J=125^{\circ}C$ | -- | 2.00 | -- | |
| $V_{GE(TH)}$ | Gate Threshold Voltage | $V_{CE} = V_{GE}, I_C = 1mA$ | 4.8 | 5.5 | 6.2 | V |



迈诺斯科技

MLG50T65FUK

IGBT

| | | | | | | |
|--------------|--------------------------------------|---|----------------|----------------------|------------------|---------|
| V_F | Diode Forward Voltage | $I_F=25A$ $T_J=25^\circ C$ $T_J=125^\circ C$ $T_J=175^\circ C$ | -- -- -- | 1.70 1.30 1.15 | 2.30 -- -- | V |
| V_F | Diode Forward Voltage | $I_F=25A$ $T_J=25^\circ C$ $T_J=125^\circ C$ $T_J=175^\circ C$ | -- -- -- | 2.00 1.65 1.50 | 2.60 -- -- | V |
| I_{CES} | Collector-Emitter Leakage Current | $V_{CE} = 650V,$ $V_{GE} = 0V$ | -- | -- | 4 | μA |
| $I_{GES(F)}$ | Gate-Emitter Forward Leakage Current | $V_{GE} = +30V$ | -- | -- | 200 | nA |
| $I_{GES(R)}$ | Gate-Emitter Reverse Leakage Current | $V_{GE} = -30V$ | -- | -- | -200 | nA |

Pulse width $t_p \leq 300\mu s, \delta \leq 2\%$

Dynamic Characteristics

| Symbol | Parameter | Test Conditions | Values | | | Units |
|-------------|---|---|--------|------|------|-------|
| | | | Min. | Typ. | Max. | |
| C_{iss} | Input Capacitance | $V_{GE}=0V$ $V_{CE}=25V$ $f = 1.0MHz$ | -- | 2109 | -- | pF |
| C_{oss} | Output Capacitance | | -- | 158 | -- | |
| C_{rss} | Reverse Transfer Capacitance | | -- | 24 | -- | |
| Q_G | Gate charge | $V_{CC}=520V$ $I_{CE}=50A$ $V_{GE}=15V$ | -- | 106 | -- | nC |
| Q_{GE} | Gate-emitter charge | | -- | 53 | -- | |
| Q_{GC} | Gate-collector charge | | -- | 22 | -- | |
| $I_{C(SC)}$ | Short circuit collector current Max.1000 short circuits, Times between short circuits: $\geq 1.0s$ | $V_{GE}=15.0V, V_{CC} \leq 400V,$ $t_{sc} \leq 8\mu s, T_J \leq 175^\circ C$ | | 250 | | A |

IGBT Switching Characteristics, at $T_J=25^\circ C$

| Symbol | Parameter | Test Conditions | Values | | | Units |
|--------------|-------------------------|---|--------|------|------|-------|
| | | | Min. | Typ. | Max. | |
| $t_{d(on)}$ | Turn-on Delay Time | $I_C = 50A$ $V_{CE} = 400V$ $V_{GE} = 15V$ $R_G = 5\Omega$ $T_J = 25^\circ C$ Inductive Load | -- | 22 | -- | ns |
| t_r | Rise Time | | -- | 44 | -- | |
| $t_{d(off)}$ | Turn-Off Delay Time | | -- | 102 | -- | |
| t_f | Fall Time | | -- | 59 | -- | mJ |
| E_{on} | Turn-On Switching Loss | | -- | 0.98 | -- | |
| E_{off} | Turn-Off Switching Loss | | -- | 0.81 | -- | |
| E_{ts} | Total Switching Loss | | -- | 1.79 | -- | |

IGBT Switching Characteristics, at $T_J=175^\circ\text{C}$

| Symbol | Parameter | Test Conditions | Values | | | Units |
|--------------|-------------------------|---|--------|------|------|-------|
| | | | Min. | Typ. | Max. | |
| $t_{d(on)}$ | Turn-on Delay Time | $I_C = 50\text{A}$ $V_{CE} = 400\text{V}$ $V_{GE} = 15\text{V}$ $R_G = 5\Omega$ $T_J = 175^\circ\text{C}$ Inductive Load | -- | 22 | -- | ns |
| t_r | Rise Time | | -- | 41 | -- | |
| $t_{d(off)}$ | Turn-Off Delay Time | | -- | 182 | -- | |
| t_f | Fall Time | | -- | 115 | -- | |
| E_{on} | Turn-On Switching Loss | | -- | 1.06 | -- | mJ |
| E_{off} | Turn-Off Switching Loss | | -- | 1.48 | -- | |
| E_{ts} | Total Switching Loss | -- | 2.54 | -- | | |

Diode Characteristics, at $T_J=25^\circ\text{C}$

| Symbol | Parameter | Test Conditions | Values | | | Units |
|-----------|--------------------------|---|--------|------|------|-------|
| | | | Min. | Typ. | Max. | |
| T_{rr} | Reverse Recovery Time | $I_F = 25\text{A}$, $di/dt = 200\text{A}/\mu\text{s}$, $T_J = 25^\circ\text{C}$ | -- | 200 | -- | ns |
| Q_{rr} | Reverse Recovery Charge | | -- | 380 | -- | nC |
| I_{rrm} | Reverse Recovery Current | | -- | 4.8 | -- | A |
| T_{rr} | Reverse Recovery Time | $I_F = 50\text{A}$, $di/dt = 200\text{A}/\mu\text{s}$, $T_J = 25^\circ\text{C}$ | -- | 210 | -- | ns |
| Q_{rr} | Reverse Recovery Charge | | -- | 220 | -- | nC |
| I_{rrm} | Reverse Recovery Current | | -- | 4.4 | -- | A |

Diode Characteristics, at $T_J=175^\circ\text{C}$

| Symbol | Parameter | Test Conditions | Values | | | Units |
|-----------|--------------------------|--|--------|------|------|-------|
| | | | Min. | Typ. | Max. | |
| T_{rr} | Reverse Recovery Time | $I_F = 25\text{A}$, $di/dt = 200\text{A}/\mu\text{s}$, $T_J = 175^\circ\text{C}$ | -- | 213 | -- | ns |
| Q_{rr} | Reverse Recovery Charge | | -- | 1607 | -- | nC |
| I_{rrm} | Reverse Recovery Current | | -- | 13 | -- | A |
| T_{rr} | Reverse Recovery Time | $I_F = 50\text{A}$, $di/dt = 200\text{A}/\mu\text{s}$, $T_J = 175^\circ\text{C}$ | -- | 266 | -- | ns |
| Q_{rr} | Reverse Recovery Charge | | -- | 1704 | -- | nC |
| I_{rrm} | Reverse Recovery Current | | -- | 12 | -- | A |

5. Characteristics Curves

Figure 1. Forward Bias Safe Operating Area for TO3PN/TO247

Figure 2. Power Dissipation vs Case Temperature for TO3PN/TO247

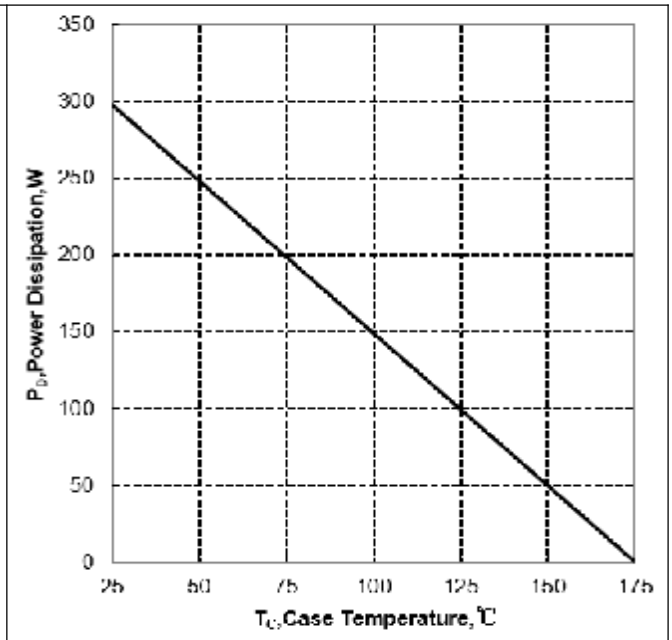
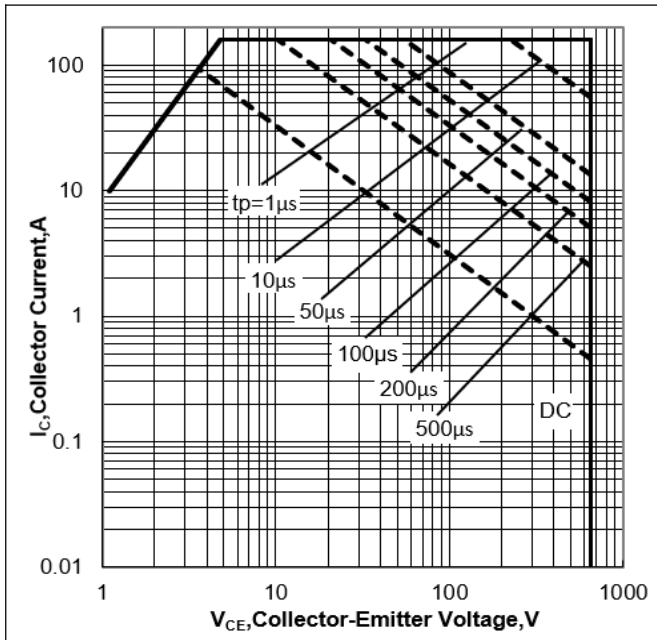

Figure 3. Collector Current vs Case Temperature

Figure 4. Typical Transfer Characteristics

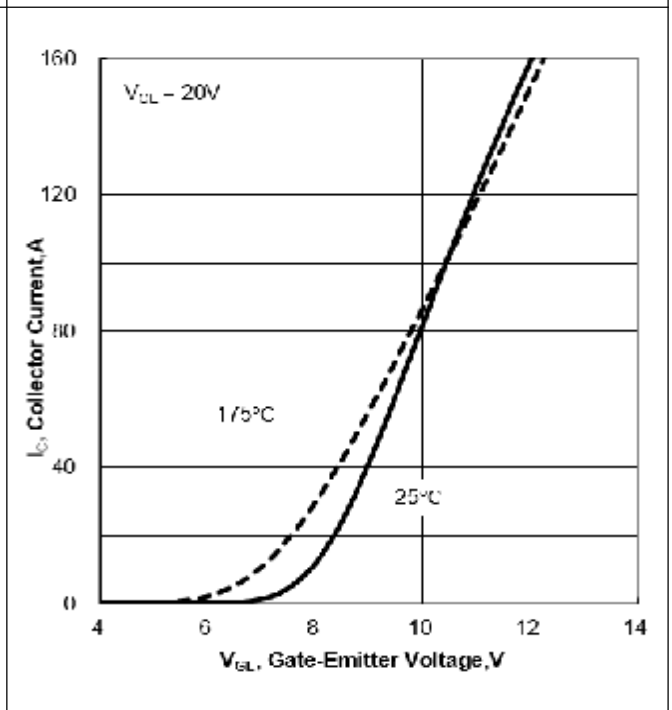
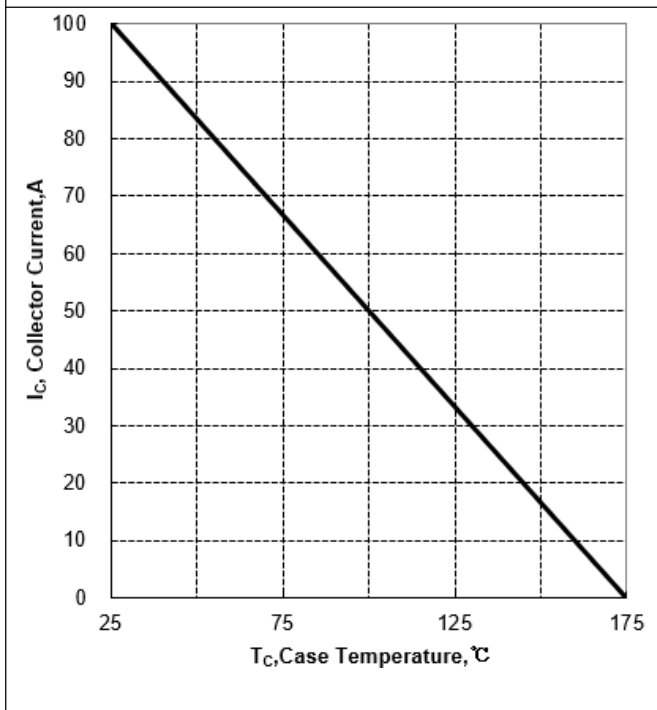

Figure 5. Typical Output Characteristics
($T_J=25^\circ\text{C}$)

Figure 6. Typical Output Characteristics
($T_J=175^\circ\text{C}$)

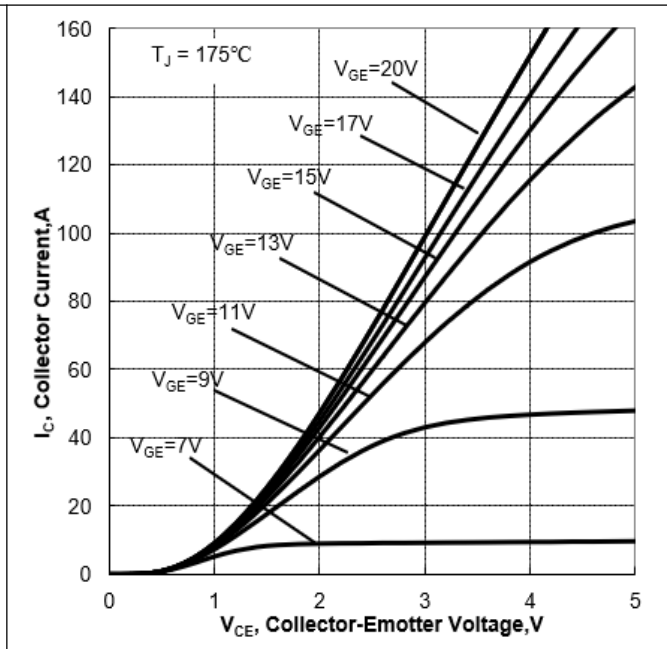
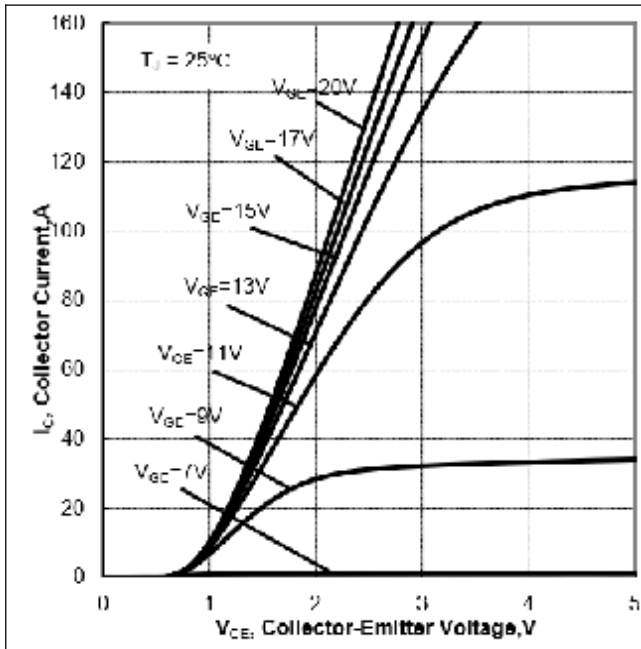

Figure 7. Typical Collector-Emitter Saturation Voltage vs Junction Temperature

Figure 8. Typical Gate-Emitter Threshold Voltage vs Junction Temperature

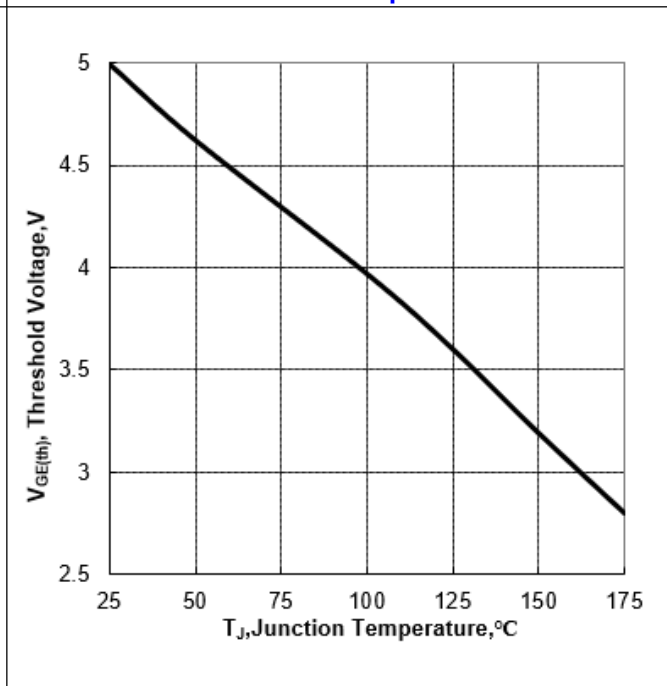
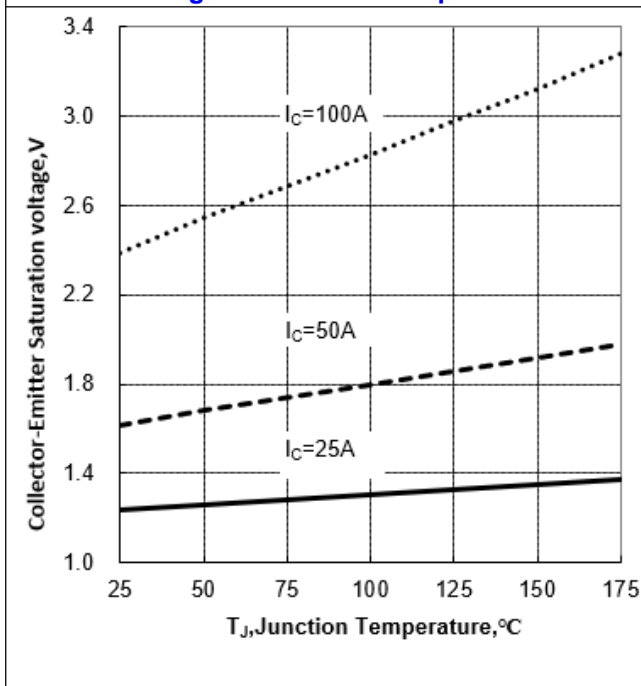

Figure 9. Typical Switching Times vs Gate Resistor ($T_J=25^\circ\text{C}$, $V_{CE}=400\text{V}$, $V_{GE}=15/0\text{V}$, $I_C=50\text{A}$)

Figure 10. Typical Switching Energy vs Gate Resistor ($T_J=25^\circ\text{C}$, $V_{CE}=400\text{V}$, $V_{GE}=15/0\text{V}$, $I_C=50\text{A}$)

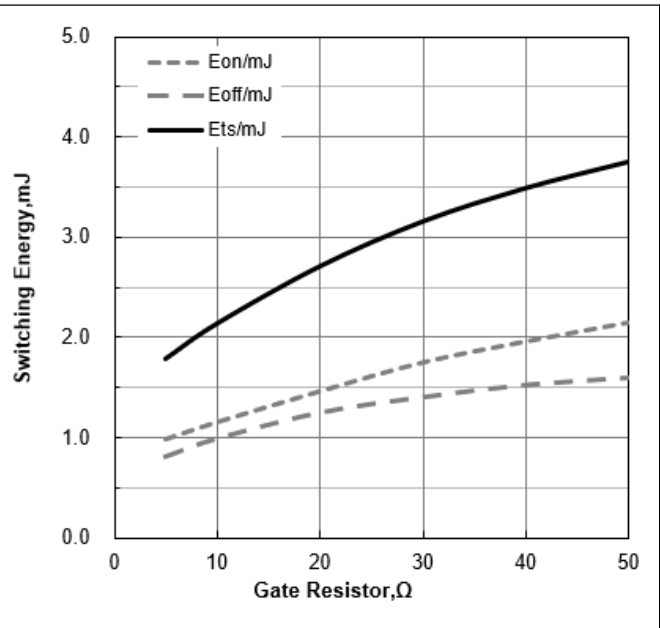
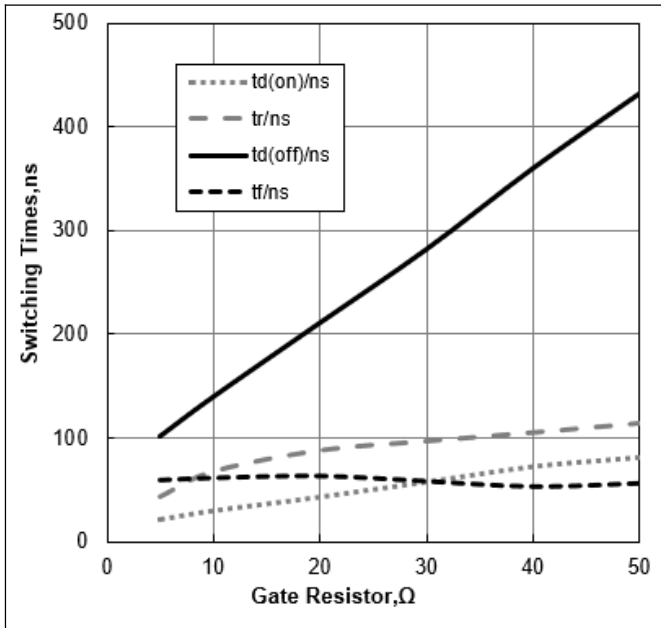

Figure 11. Typical Switching Times vs Junction Temperature ($V_{CE}=400V$, $V_{GE}=15/0V$, $I_c=50A$)

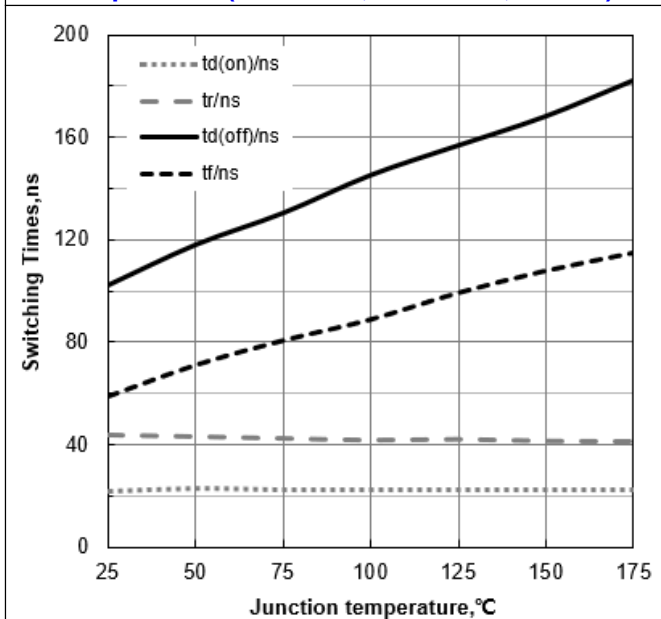

Figure 12. Typical Switching Energy vs Junction Temperature ($V_{CE}=400V$, $V_{GE}=15/0V$, $I_c=50A$)

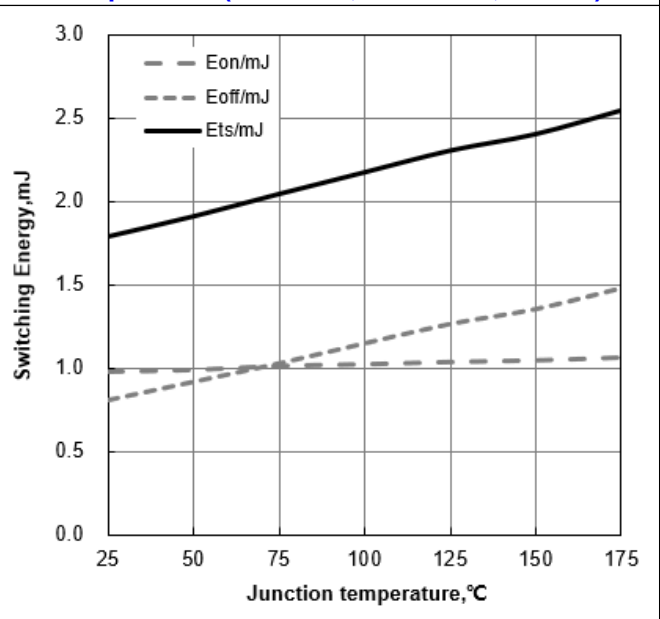

Figure 13. Typical Switching Times vs Collector Current ($T_J=25^\circ C$, $V_{CE}=400V$, $V_{GE}=15/0V$)

Figure 14. Typical Switching Energy vs Collector Current ($T_J=25^\circ C$, $V_{CE}=400V$, $V_{GE}=15/0V$)

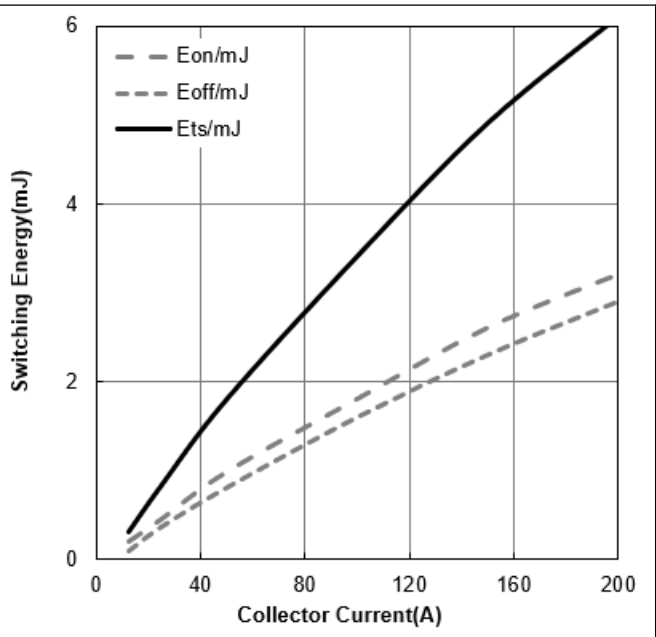
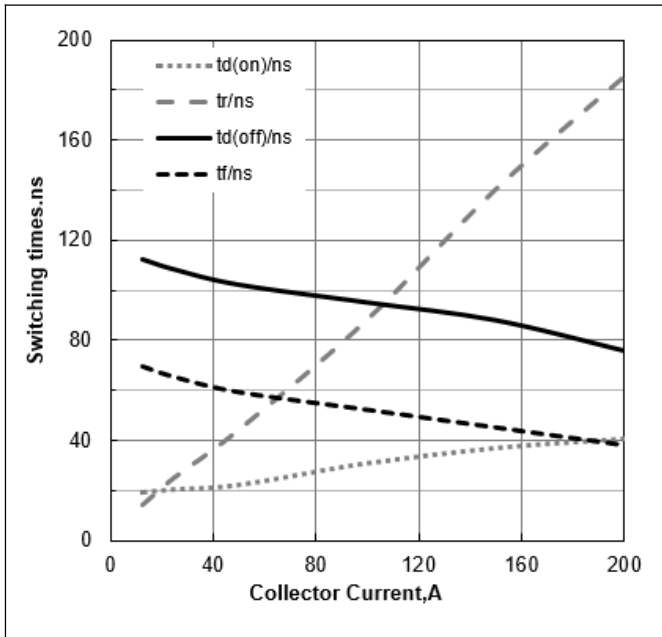

Figure 15. Typical Switching Times vs V_{CE}
($T_J=25^\circ\text{C}$, $V_{GE}=15/0\text{V}$, $I_C=50\text{A}$)

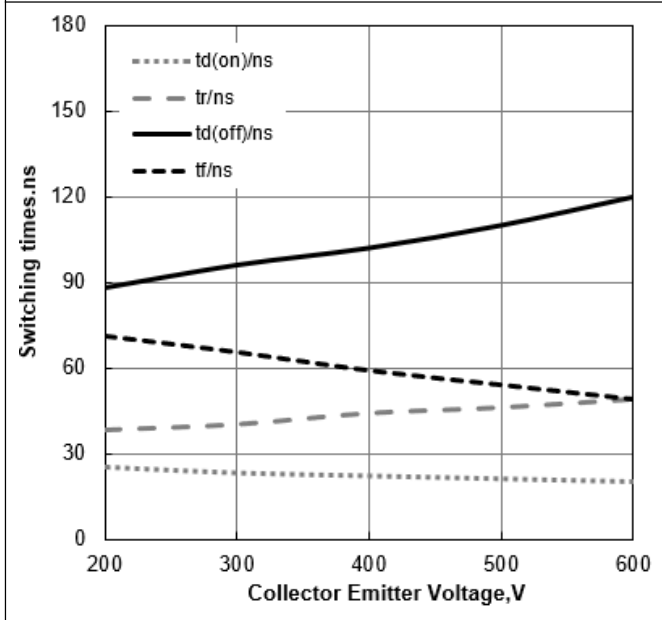

Figure 16. Typical Switching Energy vs V_{CE}
($T_J=25^\circ\text{C}$, $V_{GE}=15/0\text{V}$, $I_C=50\text{A}$)

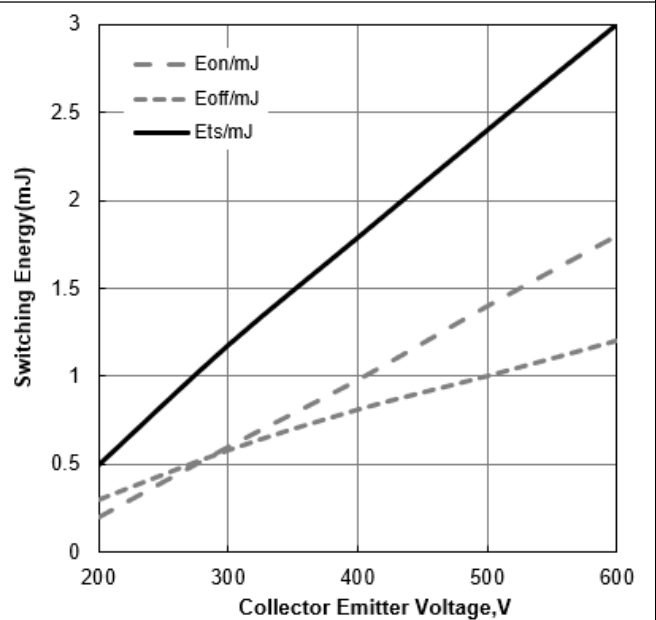

Figure 17. Typical Gate Charge

Figure 18. Typical Capacitance vs Collector-Emitter Voltage

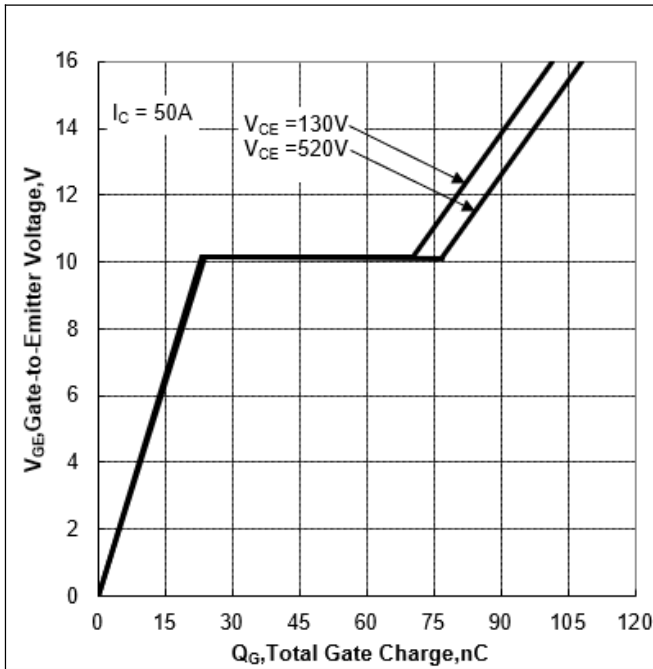

Figure 19. IGBT Transient Thermal Impedance vs Pulse Width(TO3PN/TO247)

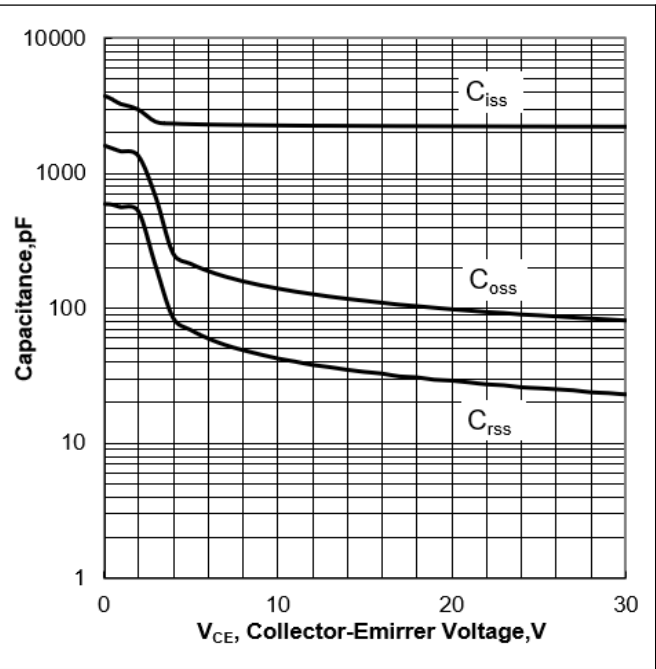

Figure 20. Diode Transient Thermal Impedance vs Pulse Width(TO3PN/TO247)

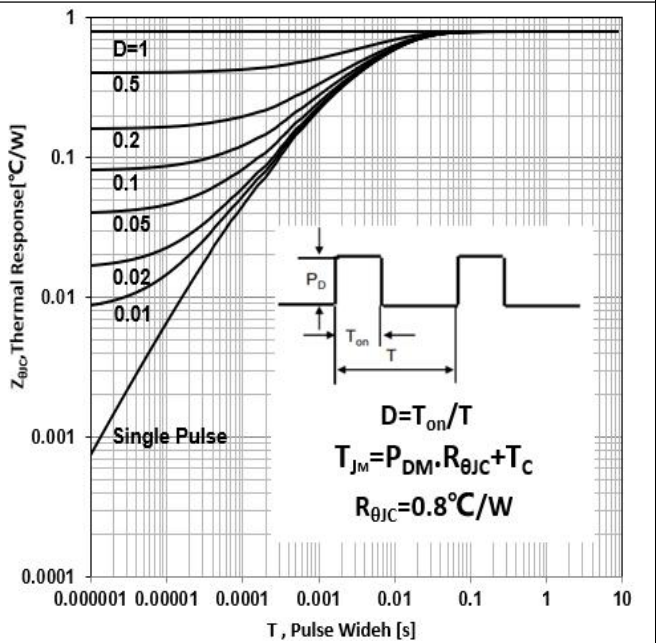
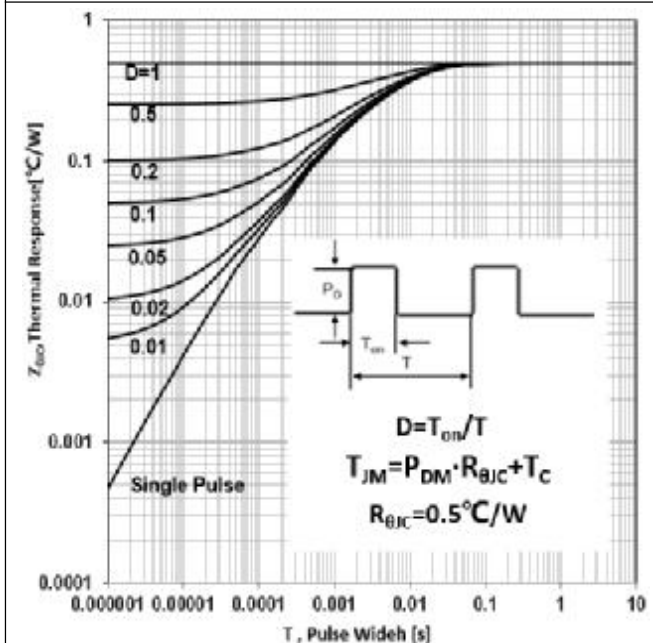

Figure 21. Typical Diode Forward Current vs Forward Voltage



迈诺斯科技

MLG50T65FUK

IGBT

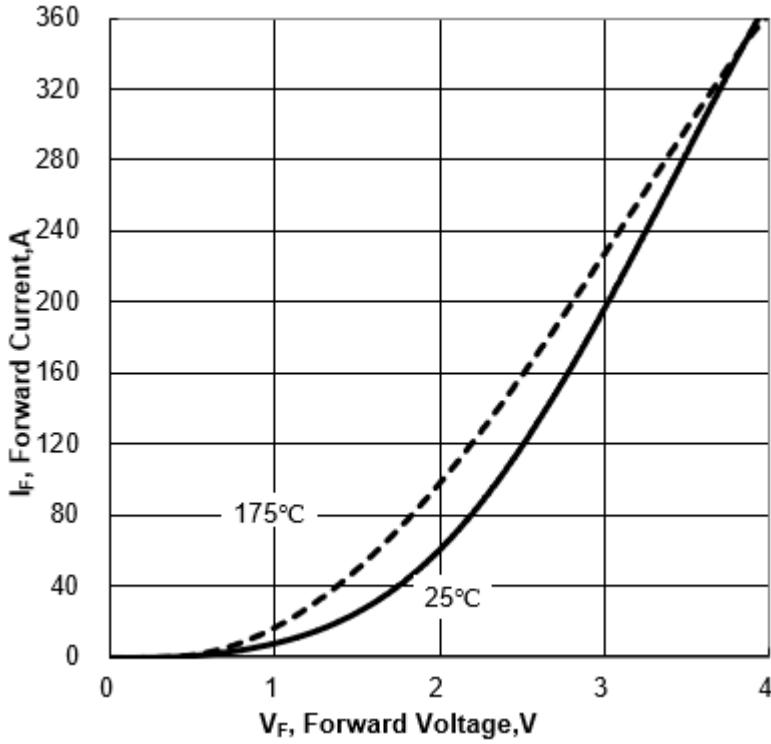

6. Test Circuit and Waveform

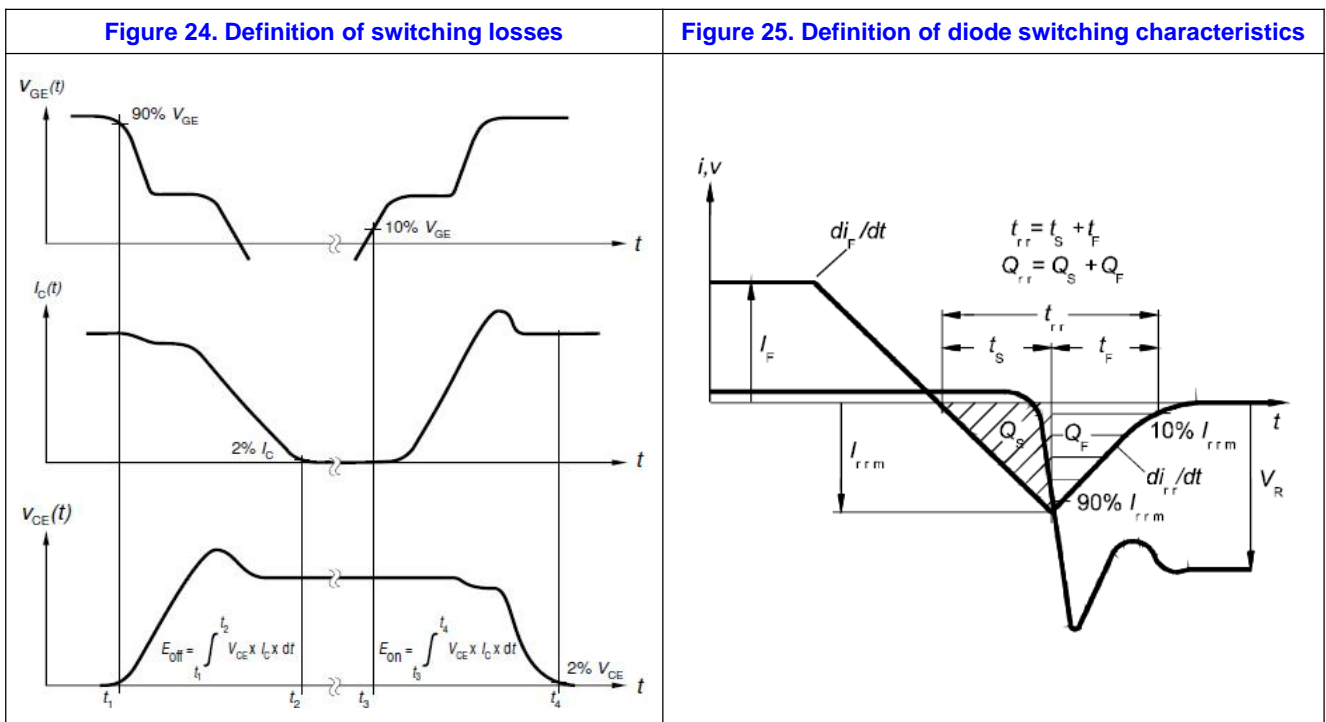
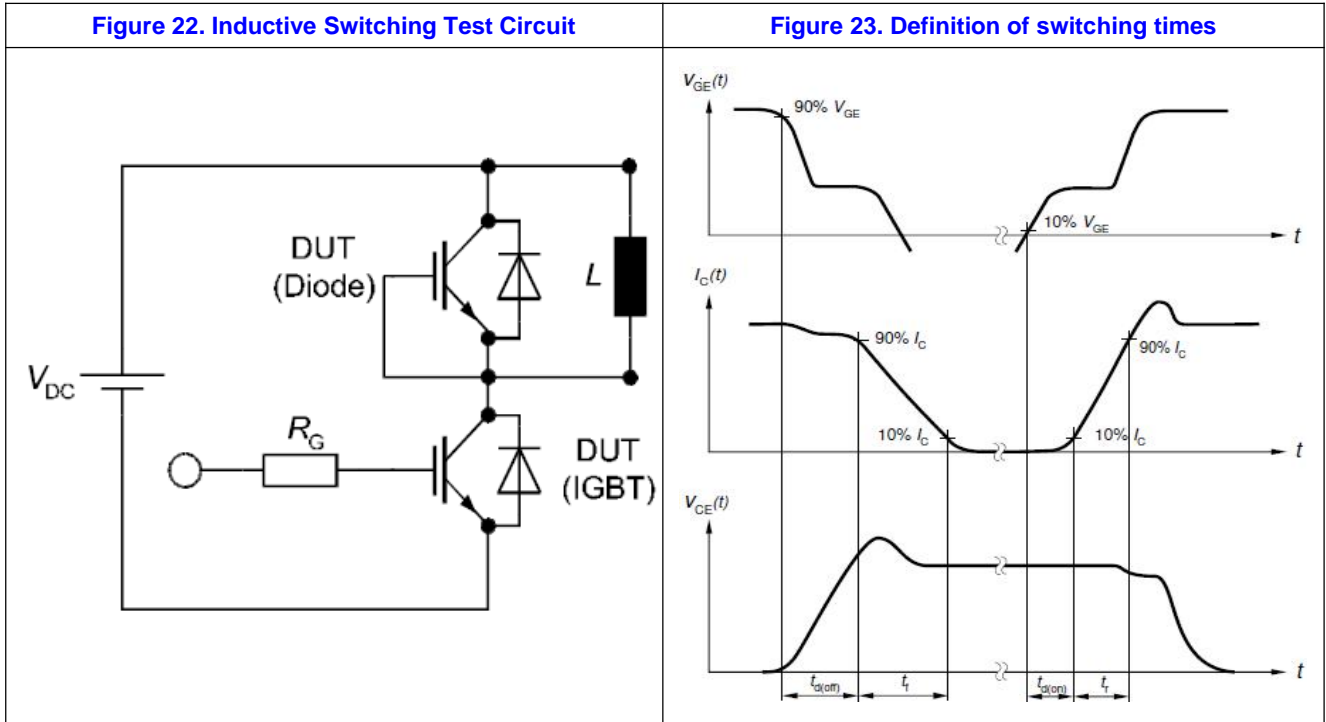

7. Package Description

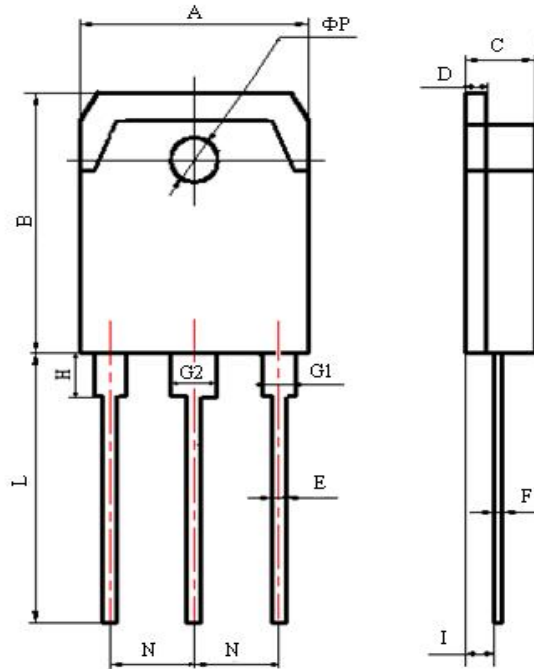

TO-3PN Package

| Items | Values(mm) | |
|-------|------------|-------|
| | MIN | MAX |
| A | 15.00 | 16.00 |
| B | 19.20 | 20.60 |
| C | 4.60 | 5.00 |
| D | 1.40 | 1.60 |
| E | 0.90 | 1.10 |
| F | 0.50 | 0.70 |
| G1 | 2.00 | 2.20 |
| G2 | 3.00 | 3.20 |
| H | 3.00 | 3.70 |
| I | 1.20 | 1.70 |
| | 2.70 | 2.90 |
| L | 19.00 | 21.00 |
| N | 5.25 | 5.65 |
| Φ P | 3.10 | 3.30 |

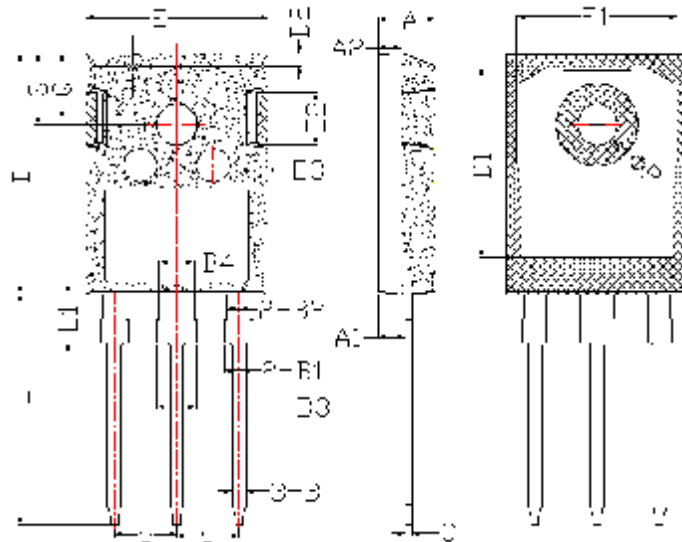

TO-247 Package

| Items | Values(mm) | |
|-------|------------|-------|
| | MIN | MAX |
| A | 4.90 | 5.16 |
| A1 | 2.27 | 2.53 |
| A2 | 1.85 | 2.11 |
| B | 1.07 | 1.33 |
| B1 | 1.90 | 2.41 |
| B2 | 1.75 | 2.15 |
| B3 | 2.87 | 3.38 |
| B4 | 2.87 | 3.13 |
| C | 0.55 | 0.68 |
| D | 20.82 | 21.10 |
| D1 | 16.25 | 17.65 |
| D2 | 1.05 | 1.35 |
| E | 15.70 | 16.03 |
| E1 | 13.10 | 14.15 |
| E2 | 3.68 | 5.10 |
| E3 | 1.68 | 2.60 |
| e | 5.44 | |
| L | 19.80 | 20.31 |
| L1 | 4.17 | 4.47 |
| ΦP | 3.50 | 3.70 |
| Q | 5.49 | 6.00 |
| S | 6.04 | 6.30 |



迈诺斯科技

MLG50T65FUK

IGBT

NOTE:

1. Exceeding the maximum ratings of the device in performance may cause damage to the device, even the permanent failure, which may affect the dependability of the machine. Please do not exceed the absolute maximum ratings of the device when circuit designing.
2. When installing the heat sink, please pay attention to the torsional moment and the smoothness of the heat sink.
3. IGBTs is the device which is sensitive to the static electricity, it is necessary to protect the device from being damaged by the static electricity when using it.
4. Shenzhen Minos reserves the right to make changes in this specification sheet and is subject to change without prior notice.

CONTACT:

深圳市迈诺斯科技有限公司（总部）

Address : 深圳市福田区华富街道田面社区深南中路 4026 号田面城市大厦 22B-22C

Phone : 0755-83273777

X-ON Electronics

Largest Supplier of Electrical and Electronic Components

Click to view similar products for [Minos](#) manufacturer:

Other Similar products are found below :

[2SA1837](#) [2SA1941](#) [2SA1943](#) [2SC4793](#) [2SC5198](#) [2SC5200](#) [78M05](#) [78M12](#) [A940](#) [AO3400S](#) [AO3401S](#) [AP8012H](#) [AP8022H](#) [AP8022HS](#)
[B772](#) [BT134-600E](#) [BT134S-600E](#) [BT134W](#) [BT136-600E](#) [BT136S-600E](#) [BT136S-800E](#) [BT137-600E](#) [BT139-600E](#) [BT139-800E](#) [BTA04-600B](#) [BTA12-600B](#) [BTA12-800B](#) [BTA16-600B](#) [BTA16-800B](#) [BTA41-600B](#) [BTB04-600B](#) [BTB06-600B](#) [BTB08-600B](#) [BTB12-600B](#)
[BTB20-600B](#) [C2073](#) [D882](#) [IRF1405](#) [IRF1407](#) [IRF3205](#) [IRF3205S](#) [IRF3710](#) [IRF3710STR](#) [IRF5210](#) [IRF530](#) [IRF540N](#) [IRF540NS](#)
[IRF630N](#) [IRF640](#) [IRF740](#)