

Description

MLS65R380P, the silicon N-channel Enhanced MOSFETs, is obtained by advanced Super Junction technology which reduce the conduction loss, improve switching performance. The transistor is suitable device for SMPS, high speed switching and general purpose applications.

KEY CHARACTERISTICS

- ① $V_{DS}=650V, I_D=11A, R_{DS(ON)}<0.33m\Omega @ V_{GS}=10V$

FEATURES

- ① Fast Switching
- ② 100% avalanche tested
- ③ Improved dv/dt capability

APPLICATIONS

- ① High frequency switching mode power supply

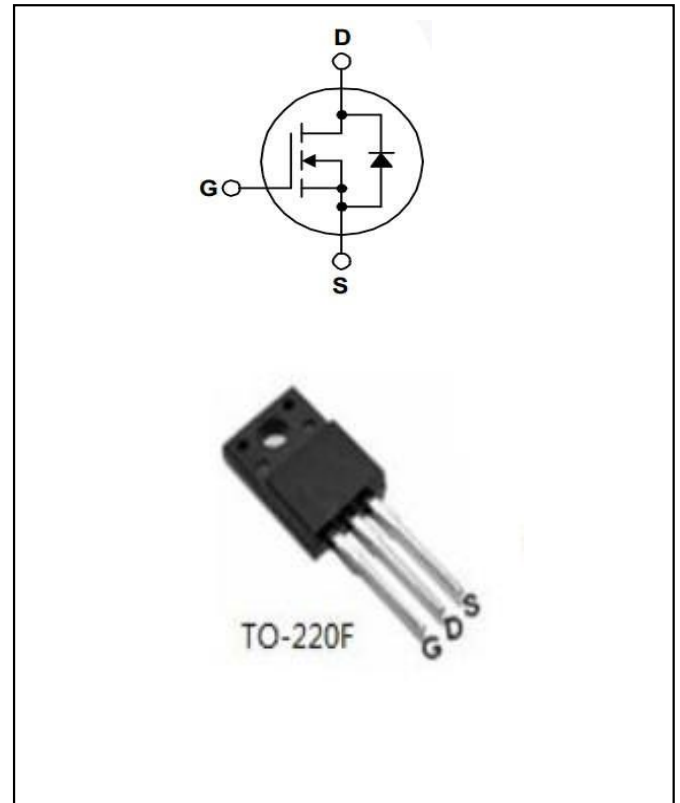

Package Marking And Ordering Information:

Ordering Codes	Package	Product Code	Packing
MLS65R380P	TO-220F	M65R380P	Tube

Electrical Characteristics @ Ta=25°C (unless otherwise specified)

Limited Parameters:

Symbol	Parameter	Value	Units
V_{DSS}	Drain-to-Source Breakdown Voltage	650	V
I_D	Drain Current (continuous) at $T_c=25^\circ C$	11	A
I_{DM}	Drain Current (pulsed)	33	A
V_{GS}	Gate to Source Voltage	± 20	V
P_{tot}	Total Dissipation at $T_c=25^\circ C$	31	W
T_j	Max. Operating Junction Temperature	150	$^\circ C$
Eas	Single Pulse Avalanche Energy	250	mj



Electrical Parameters:

Symbol	Parameter	Test Conditions	Min	Typ	Max	Unit
V _{DS}	Drain-source Voltage	V _{GS} =0V, I _D =250μA	650			V
R _{DS(on)}	Static Drain-to-Source on-Resistance	V _{GS} =10V, I _D =3.8A		0.33	0.38	mΩ
V _{GS(th)}	Gated Threshold Voltage	V _{DS} =V _{GS} , I _D =250μA	2		4	V
I _{DSS}	Drain-Source Leakage Current	V _{DS} =650V, V _{GS} =0V			1.0	μA
I _{GSS(F)}	Gate-Source Forward Leakage	V _{GS} =+30V			100	nA
I _{GSS(R)}	Gate-Source Reverse Leakage	V _{GS} =-30V			-100	nA
C _{iss}	Input Capacitance	V _{GS} =0V V _{DS} =25 V _f =1.0MHz		770		pF
C _{oss}	Output Capacitance			560		pF
C _{rss}	Reverse Transfer Capacitance			25		pF
Q _g	Total Gate Charge		I _D =4.8A		21.8	
Q _{gs}	Gate-Source Charge	V _{DD} =520V V _{GS} =10V		4.5		nC
Q _{gd}	Gate-Drain Charge			8		nC

Symbol	Parameter	Test Conditions	Min	Typ	Max	Unit
t _{d(on)}	Turn-on Delay Time	I _D =4.8A V _{DD} =400V V _{GS} =10 V _{RG} =5Ω		11		nS
t _r	Turn-on Rise Time			9		nS
t _{d(off)}	Turn-off Delay Time			38		nS
t _f	Turn-off Fall Time			8		nS

Source-Drain Diode Characteristics						
Symbol	Parameter	Test Conditions	Values			Units
			Min.	Typ.	Max.	
I _S	Continuous Source Current (Body Diode)	TC=25 °C	--	--	11	A
I _{SM}	Maximum Pulsed Current (Body Diode)		--	--	33	A
V _{SD}	Diode Forward Voltage	I _S =4.8A, V _{GS} =0V(Note4)	--	--	0.9	V
T _{rr}	Reverse Recovery Time	I _S =4.8A, T _j =25°C dI _F /dt=100A/us, V _{GS} =0V	--	285	--	ns
Q _{rr}	Reverse Recovery Charge		--	3135	--	nC
I _{rrm}	Reverse Recovery Current		--	22	--	A

Characteristics Curves

Figure 1a Safe Operating Area (No FullPAK)

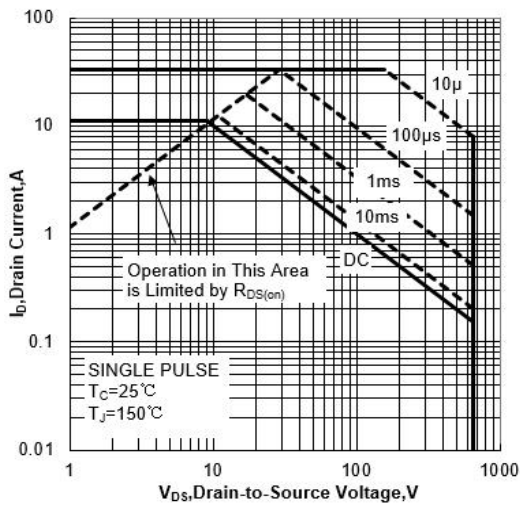

Figure 1b Safe Operating Area (FullPAK)

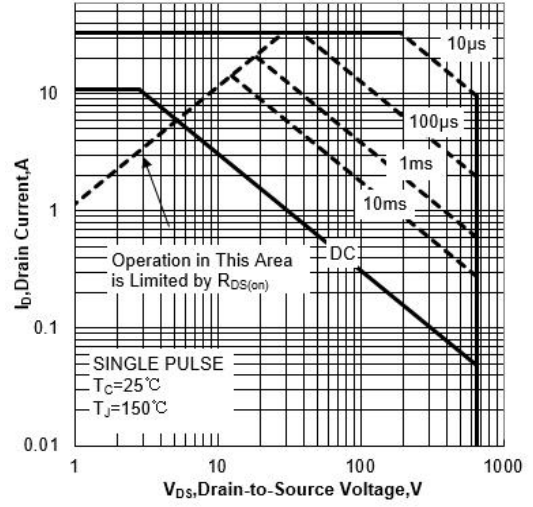

Figure 2a Power Dissipation (No FullPAK)

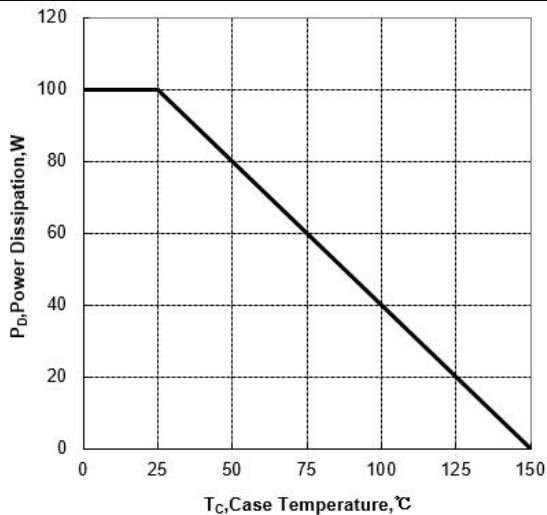

Figure 2b Power Dissipation (FullPAK)

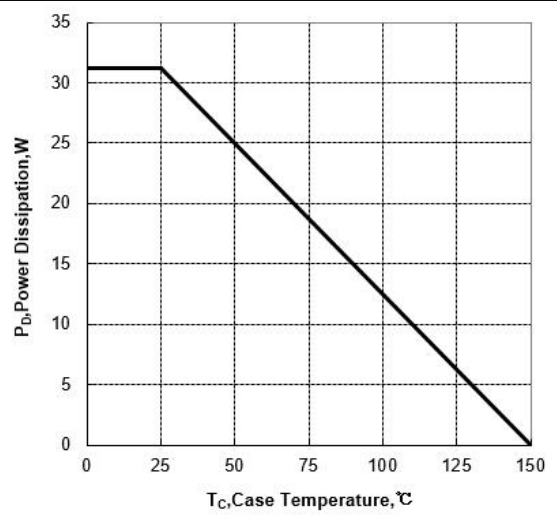

Figure 6 Typical Drain to Source ON Resistance vs Drain Current

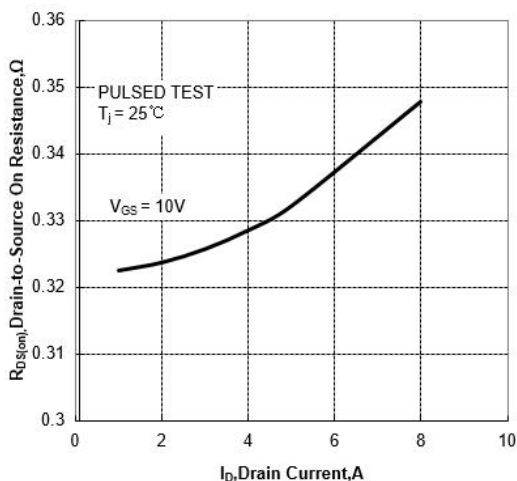

Figure 7 Typical Drain to Source on Resistance vs Junction Temperature

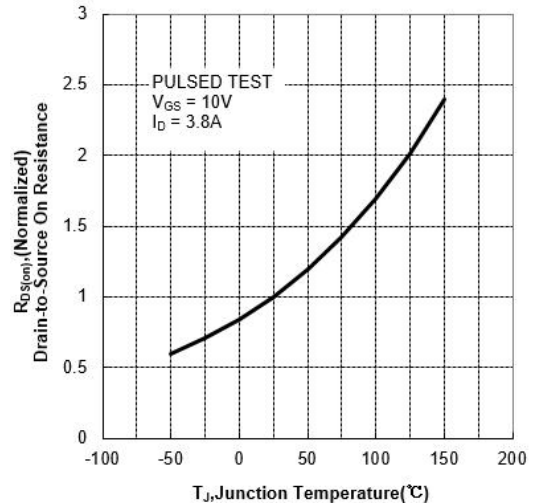

Figure 8 Typical Theshold Voltage vs Junction Temperature

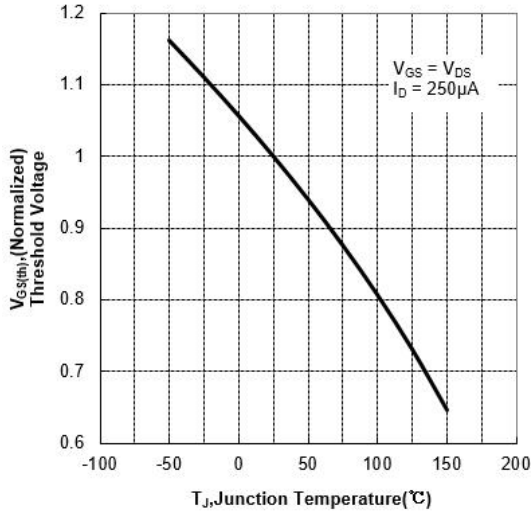

Figure 9 Typical Breakdown Voltage vs Junction Temperature

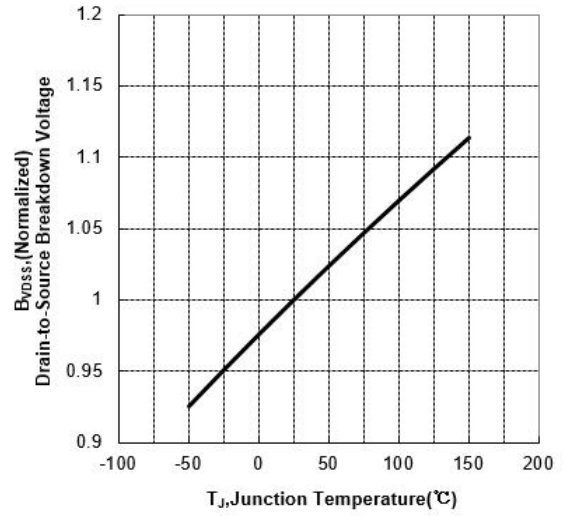

Figure 10 Typical Theshold Voltage vs Junction Temperature

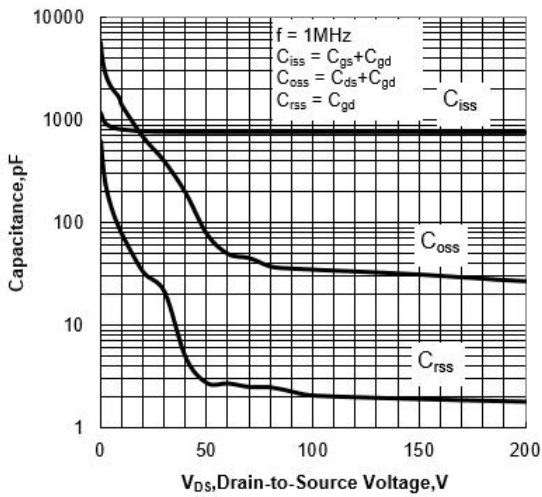
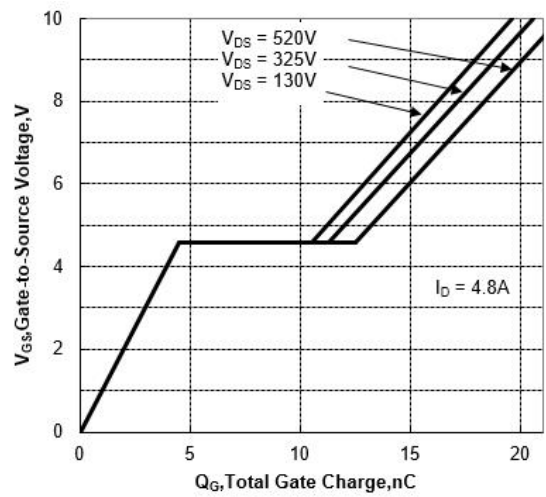

Figure 11 Typical Breakdown Voltage vs Junction Temperature



Test Circuit and Waveform

Figure 12 Gate Charge Test Circuit

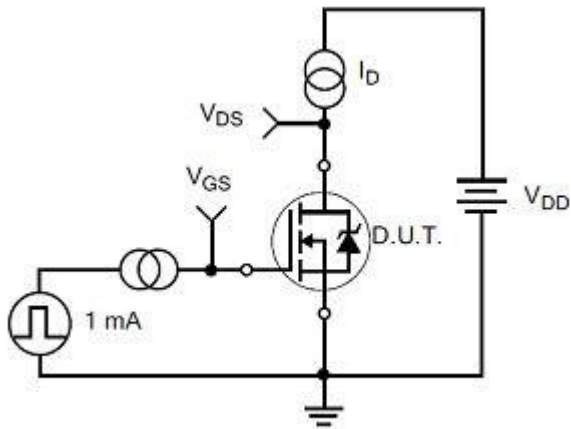

Figure 13 Gate Charge Waveforms

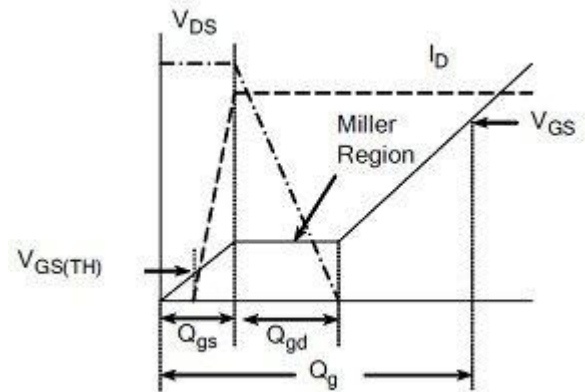

Figure 14 Resistive Switching Test Circuit

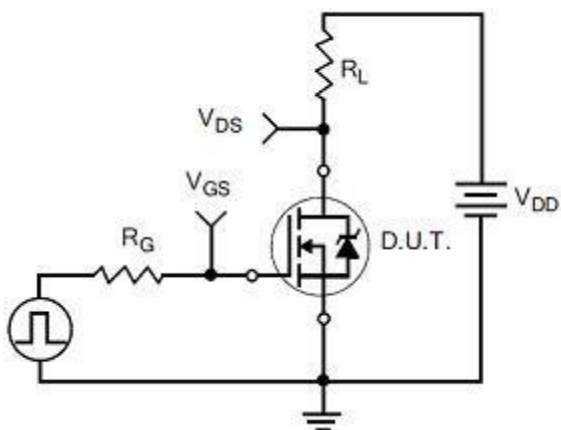

Figure 15 Resistive Switching Waveforms

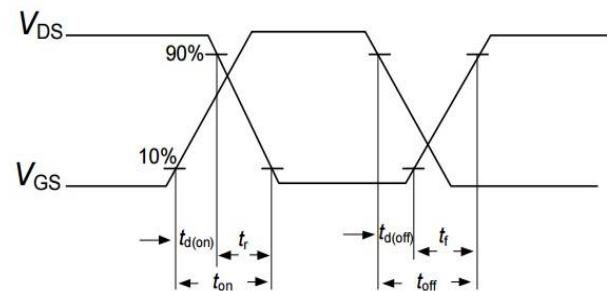

Figure 16 Diode Reverse Recovery Test Circuit

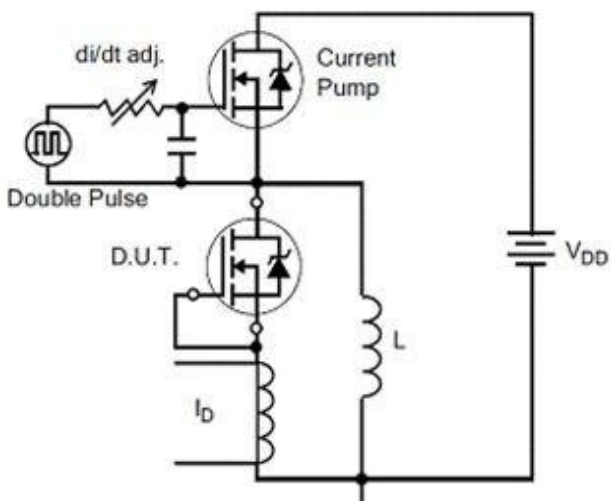

Figure 17 Diode Reverse Recovery Waveform

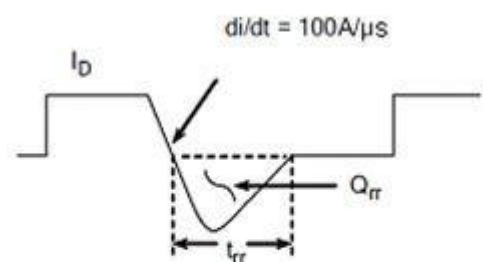

Figure 18 Unclamped Inductive Switching Test Circuit

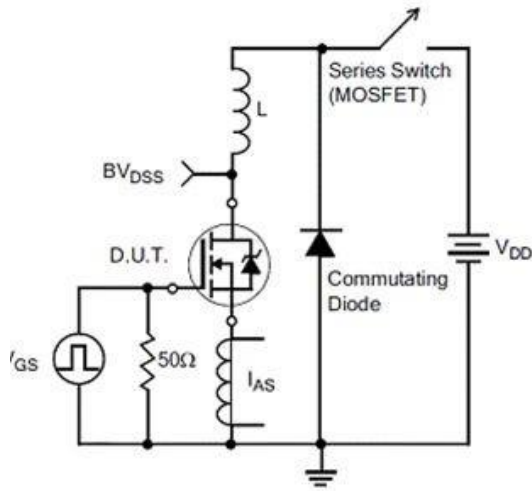
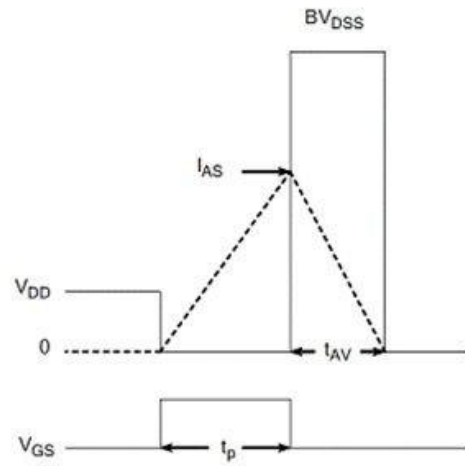
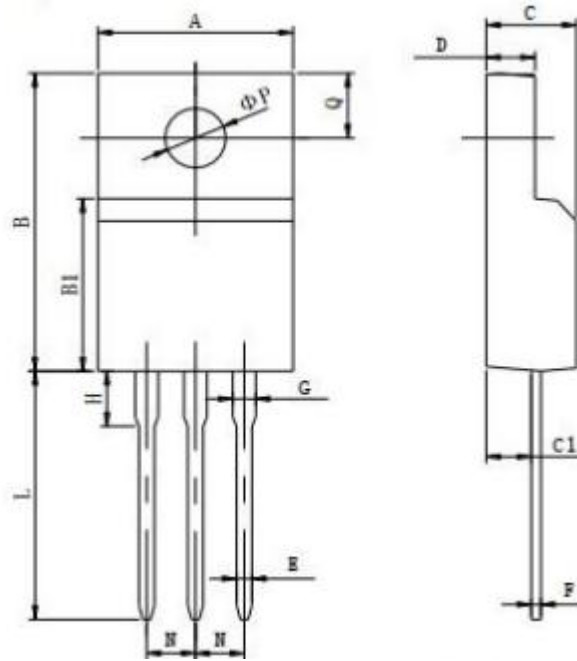

Figure 19 Unclamped Inductive Switching Waveform



Package Description



Items	Values(mm)	
	MIN	MAX
A	9.60	10.4
B	15.4	16.2
B1	8.90	9.50
C	4.30	4.90
C1	2.10	3.00
D	2.40	3.00
E	0.60	1.00
F	0.30	0.60
G	1.12	1.42
H	3.40	3.80
	1.60	2.90
L	12.0	14.0
N	2.34	2.74
Q	3.15	3.55
ϕp	2.90	3.30

TO-220F Package



NOTE:

1. Exceeding the maximum ratings of the device in performance may cause damage to the device, even the permanent failure, which may affect the dependability of the machine. Please do not exceed the absolute maximum ratings of the device when circuit designing.
2. When installing the heat sink, please pay attention to the torsional moment and the smoothness of the heat sink.
3. MOSFETs is the device which is sensitive to the static electricity, it is necessary to protect the device from being damaged by the static electricity when using it.
4. Shenzhen Minos reserves the right to make changes in this specification sheet and is subject to change without prior notice.

CONTACT:

深圳市迈诺斯科技有限公司（总部）

地址：深圳市福田区华富街道田面社区深南中路4026号田面城市大厦22B-22C

邮编：518025

电话：0755-83273777

X-ON Electronics

Largest Supplier of Electrical and Electronic Components

Click to view similar products for [MOSFET](#) category:

Click to view products by [Minos](#) manufacturer:

Other Similar products are found below :

[IRFD120](#) [IRFY240C](#) [JANTX2N5237](#) [2SK2267\(Q\)](#) [BUK455-60A/B](#) [MIC4420CM-TR](#) [VN1206L](#) [NDP4060](#) [SI4482DY](#)
[IPS70R2K0CEAKMA1](#) [SQD23N06-31L-GE3](#) [TK16J60W,S1VQ\(O](#) [2SK2614\(TE16L1,Q\)](#) [DMN1017UCP3-7](#) [EFC2J004NUZTDG](#)
[DMN1053UCP4-7](#) [SQJ469EP-T1-GE3](#) [NTE2384](#) [DMC2700UDMQ-7](#) [DMN2080UCB4-7](#) [DMN61D9UWQ-13](#) [US6M2GTR](#)
[DMN31D5UDJ-7](#) [DMP22D4UFO-7B](#) [DMN1006UCA6-7](#) [DMN16M9UCA6-7](#) [STF5N65M6](#) [IRF40H233XTMA1](#) [STU5N65M6](#)
[DMN6022SSD-13](#) [DMN13M9UCA6-7](#) [DMTH10H4M6SPS-13](#) [DMN2990UFB-7B](#) [IPB80P04P405ATMA2](#) [2N7002W-G](#) [MCAC30N06Y-](#)
[TP](#) [MCQ7328-TP](#) [NTMC083NP10M5L](#) [NVMFS2D3P04M8LT1G](#) [BXP7N65D](#) [BXP4N65F](#) [AOL1454G](#) [WMJ80N60C4](#) [BXP2N20L](#)
[BXP2N65D](#) [BXT1150N10J](#) [BXT1700P06M](#) [TSM60NB380CP](#) [ROG](#) [RQ7L055BGTCR](#) [DMNH15H110SK3-13](#)