

-200V P-Channel MOSFET

Description

MP11P20, the silicon P-channel Enhanced MOSFETs, is obtained by advanced MOSFET technology which reduce the conduction loss, improve switching performance and enhance the avalanche energy. The transistor is suitable device for SMPS, high speed switching and general purpose applications.

FEATURES

- ① Fast switching
- ② 100% avalanche tested
- ③ Improved dv/dt capability

APPLICATIONS

- ① Switch Mode Power Supply (SMPS)
- ② Uninterruptible Power Supply (UPS)
- ③ Power Factor Correction (PFC)

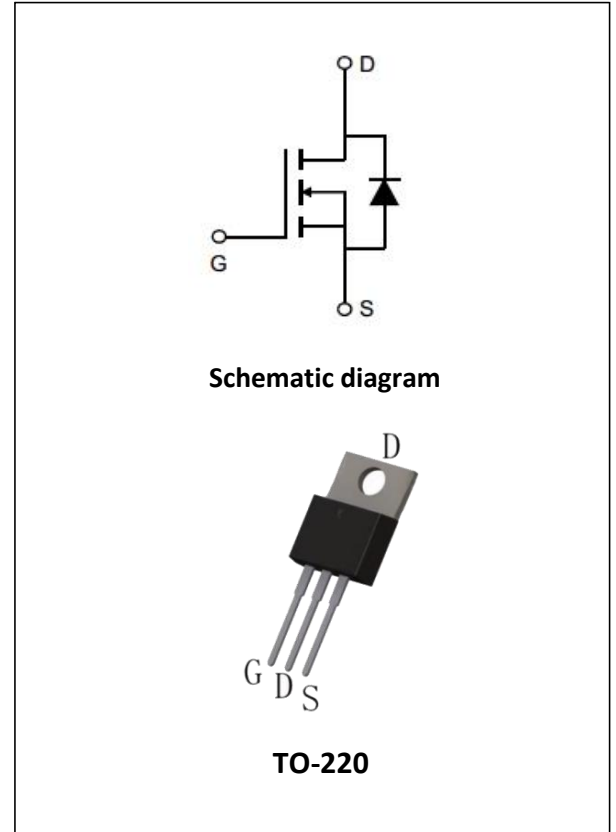

Package Marking And Ordering Information

Ordering Codes	Package	Product Code	Packing
MP11P20	TO-220	MP11P20	Tube

Absolute Maximum Ratings $T_C = 25^\circ\text{C}$, unless otherwise noted			
Parameter	Symbol	Value	Unit
Drain-Source Voltage ($V_{GS} = 0V$)	V_{DSS}	-200	V
Continuous Drain Current	I_D	-11	A
Pulsed Drain Current (note1)	I_{DM}	-44	A
Gate-Source Voltage	V_{GSS}	± 20	V
Single Pulse Avalanche Energy (note2)	E_{AS}	165	mJ
Avalanche Current (note1)	I_{AS}	-11	A
Power Dissipation ($T_C = 25^\circ\text{C}$)	P_D	78	mJ



Linear Derating Factor		0.6	W/°C
Operating Junction and Storage Temperature Range	T _J , T _{stg}	-55~+150	°C

Thermal Resistance			
Parameter	Symbol	Value	Unit
Thermal Resistance, Junction-to-Case	R _{thJC}	1.6	K/W
Thermal Resistance, Junction-to-Ambient	R _{thJA}	50	

Specifications T _J = 25°C, unless otherwise noted						
Parameter	Symbol	Test Conditions	Value			Unit
			Min.	Typ.	Max.	
Static						
Drain-Source Breakdown Voltage	V _{(BR)DSS}	V _{GS} = 0V, I _D = 250μA	-200	--	--	V
Zero Gate Voltage Drain Current	I _{DSS}	V _{DS} = -200V, V _{GS} = 0V, T _J = 25°C	--	--	5	μA
Gate-Source Leakage	I _{GSS}	V _{GS} = ±20V	--	--	±120	nA
Gate-Source Threshold Voltage	V _{GS(th)}	V _{DS} = V _{GS} , I _D = -250μA	-2	--	-4	V
Drain-Source On-Resistance (Note3)	R _{DS(on)}	V _{GS} = -10V, I _D = -6.6A	--	0.34	0.42	Ω
Dynamic						
Input Capacitance	C _{iss}	V _{GS} = 0V, V _{DS} = -25V, f = 1.0MHz	--	1200	---	pF
Output Capacitance	C _{oss}		--	370	--	
Reverse Transfer Capacitance	C _{rss}		--	81	--	
Total Gate Charge	Q _g	V _{DD} = -100V, I _D = -13.5A, V _{GS} = -10V	--	52	68	nC
Gate-Source Charge	Q _{gs}		--	9	--	
Gate-Drain Charge	Q _{gd}		--	25	--	
Turn-on Delay Time	t _{d(on)}	V _{DD} = -160V, I _D = -13.5A, R _G = 25 Ω	--	28	56	ns
Turn-on Rise Time	t _r		--	74	148	
Turn-off Delay Time	t _{d(off)}		--	260	520	

Turn-off Fall Time	t_f		--	120	240	
Drain-Source Body Diode Characteristics						
Continuous Body Diode Current	I_S	$T_C = 25\text{ }^\circ\text{C}$	--	--	-11	A
Pulsed Diode Forward Current	I_{SM}		--	--	-44	
Body Diode Voltage	V_{SD}	$T_J = 25^\circ\text{C}, I_{SD} = -11\text{A}, V_{GS} = 0\text{V}$	--	--	-5	V
Reverse Recovery Time	t_{rr}	$V_{GS} = 0\text{V}, I_S = -11\text{A},$ $di_F/dt = 100\text{A}/\mu\text{s}$	--	250	300	ns
Reverse Recovery Charge	Q_{rr}		--	2.9	3.6	μC

Notes

1. Repetitive Rating: Pulse width limited by maximum junction temperature
2. $I_{AS} = -11A$, $V_{DD} = 25V$, $R_G = 25 \Omega$, Starting $T_J = 25 \text{ }^\circ\text{C}$
3. Pulse Test: Pulse width $\leq 300\mu\text{s}$, Duty Cycle $\leq 1\%$

Characteristics Curves

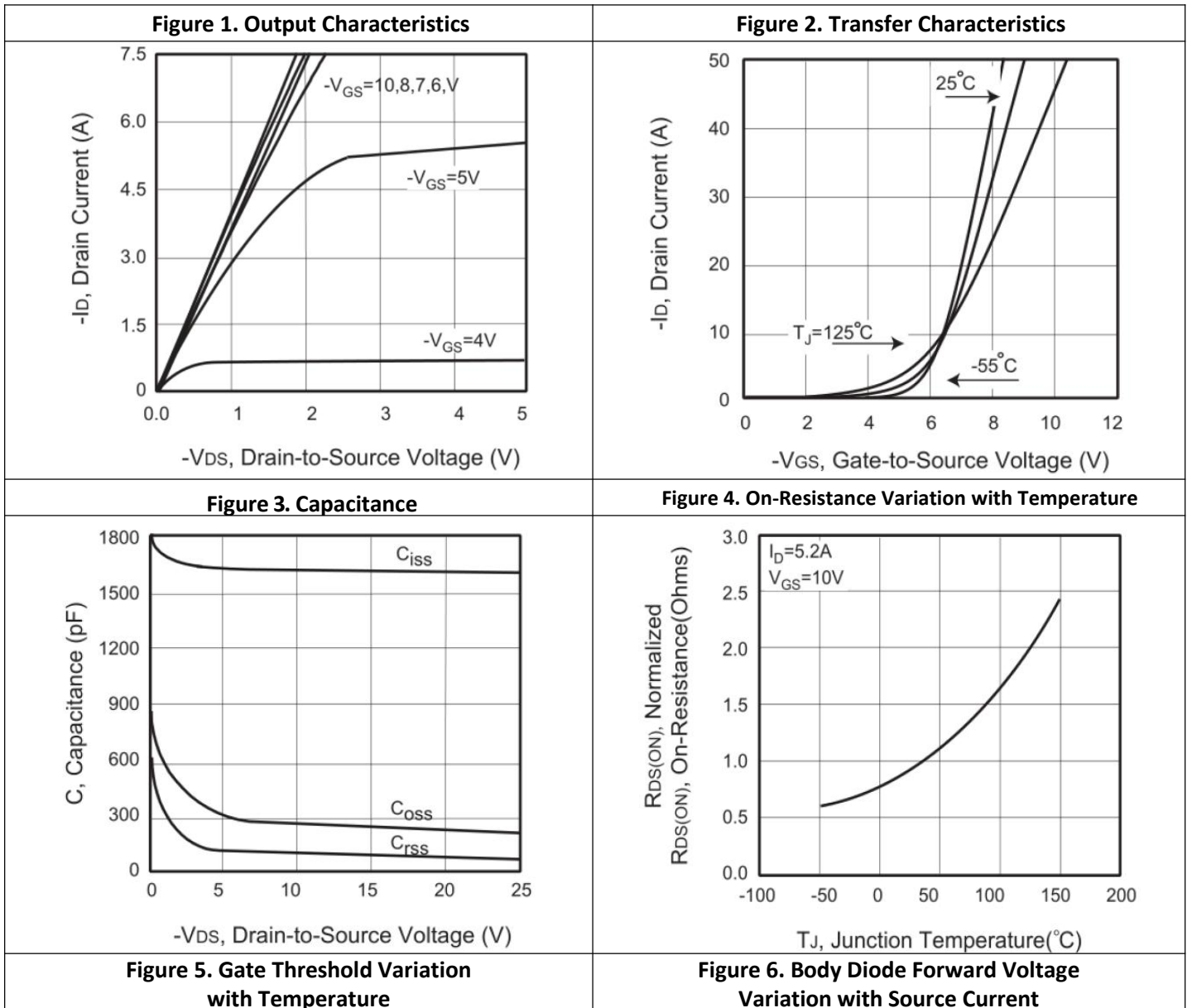

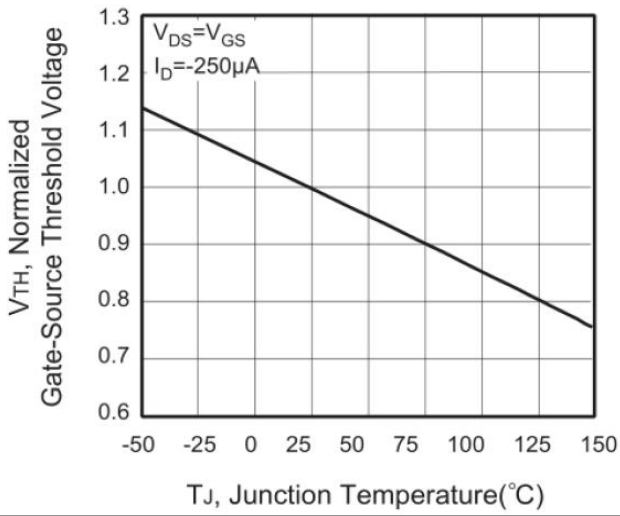

Figure 7. Gate Charge

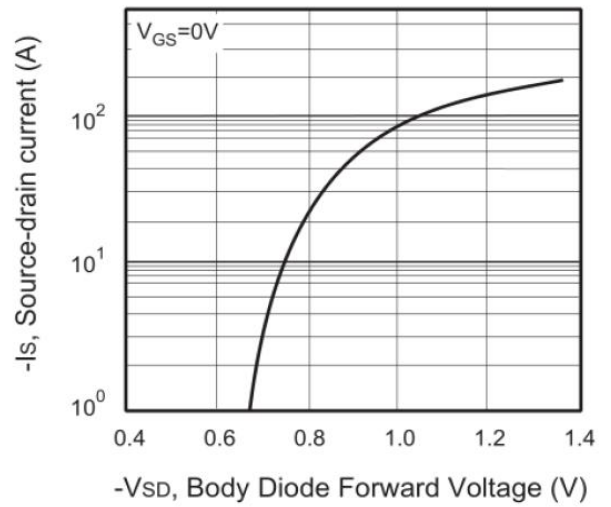

Figure 8. Maximum Safe Operating Area

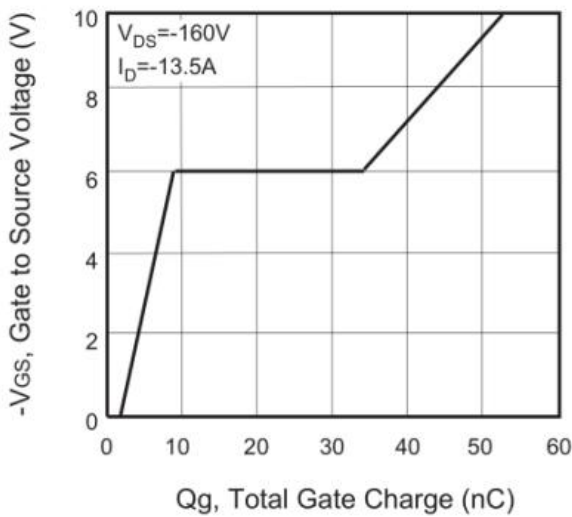

Figure 9. Switching Test Circuit

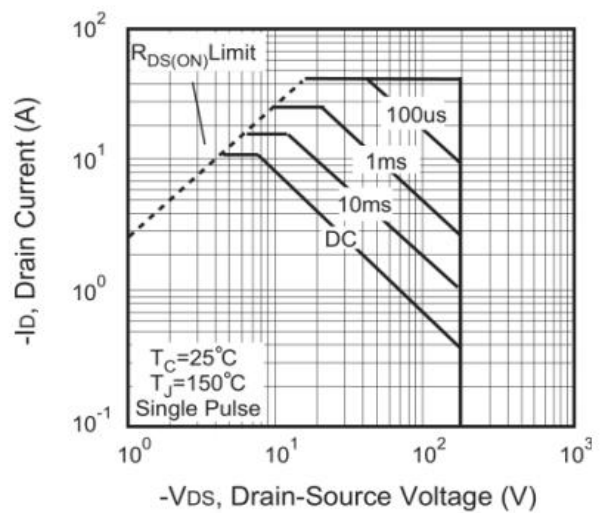

Figure 10. Switching Waveforms

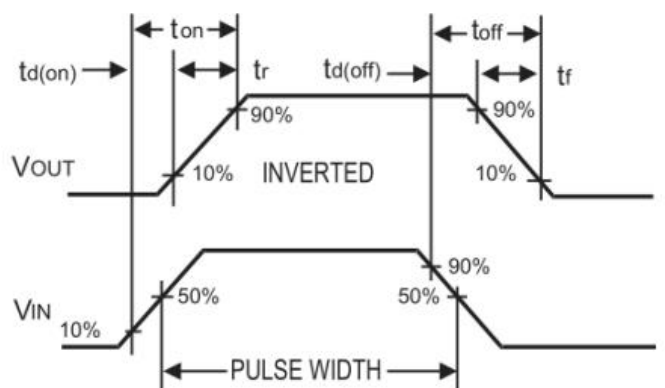
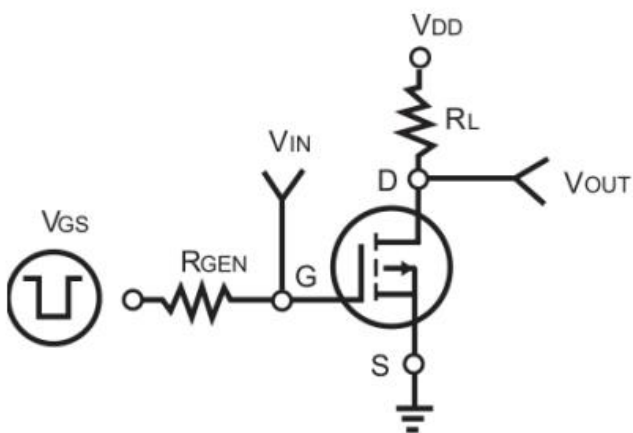
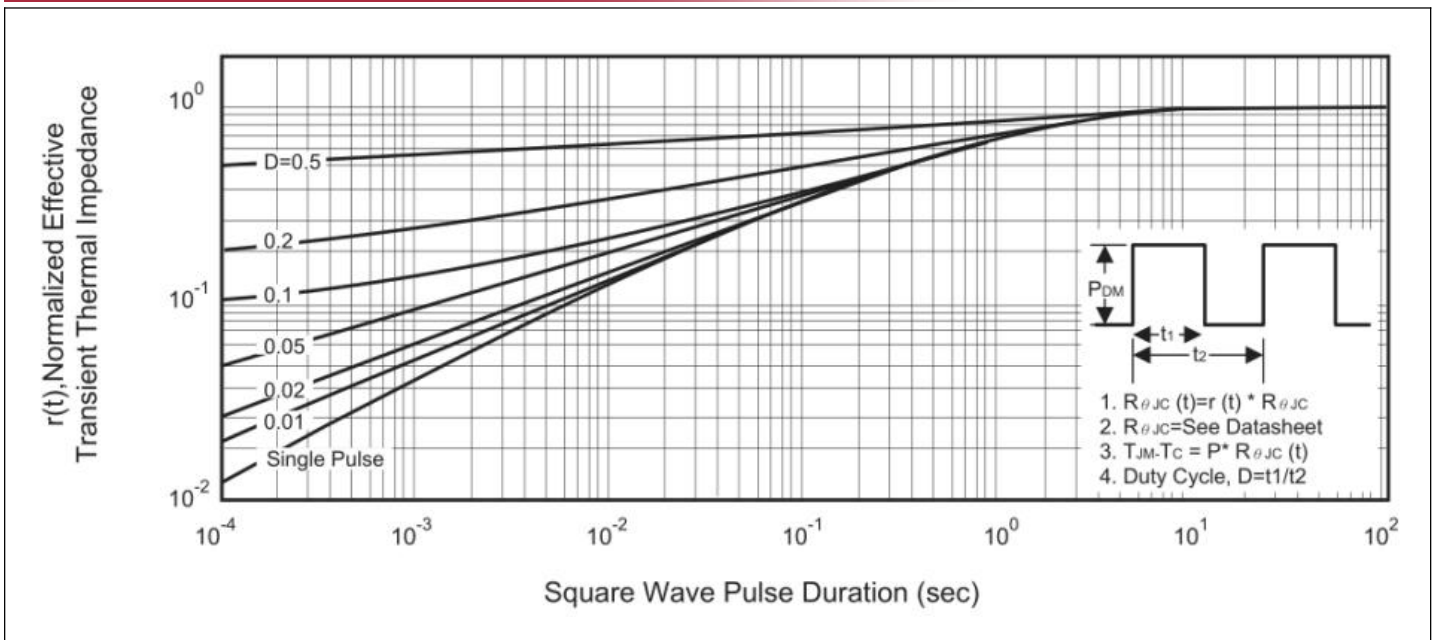

Figure 11. Normalized Thermal Transient Impedance Curve

**NOTE:**

1. Exceeding the maximum ratings of the device in performance may cause damage to the device, even the permanent failure, which may affect the dependability of the machine. Please do not exceed the absolute maximum ratings of the device when circuit designing.
2. When installing the heat sink, please pay attention to the torsional moment and the smoothness of the heat sink.
3. MOSFETs is the device which is sensitive to the static electricity, it is necessary to protect the device from being damaged by the static electricity when using it.
4. Shenzhen Minos reserves the right to make changes in this specification sheet and is subject to change without prior notice.

CONTACT:**深圳市迈诺斯科技有限公司（总部）**

地址：深圳市福田区华富街道田面社区深南中路4026号田面城市大厦22B-22C

邮编：518025

电话：0755-83273777

X-ON Electronics

Largest Supplier of Electrical and Electronic Components

Click to view similar products for [MOSFET](#) category:

Click to view products by [Minos](#) manufacturer:

Other Similar products are found below :

[IRFD120](#) [IRFY240C](#) [JANTX2N5237](#) [2SK2267\(Q\)](#) [BUK455-60A/B](#) [MIC4420CM-TR](#) [VN1206L](#) [NDP4060](#) [SI4482DY](#)
[IPS70R2K0CEAKMA1](#) [SQD23N06-31L-GE3](#) [TK16J60W,S1VQ\(O](#) [2SK2614\(TE16L1,Q\)](#) [DMN1017UCP3-7](#) [EFC2J004NUZTDG](#)
[DMN1053UCP4-7](#) [SQJ469EP-T1-GE3](#) [NTE2384](#) [DMC2700UDMQ-7](#) [DMN2080UCB4-7](#) [DMN61D9UWQ-13](#) [US6M2GTR](#)
[DMN31D5UDJ-7](#) [DMP22D4UFO-7B](#) [DMN1006UCA6-7](#) [DMN16M9UCA6-7](#) [STF5N65M6](#) [IRF40H233XTMA1](#) [STU5N65M6](#)
[DMN6022SSD-13](#) [DMN13M9UCA6-7](#) [DMTH10H4M6SPS-13](#) [DMN2990UFB-7B](#) [IPB80P04P405ATMA2](#) [2N7002W-G](#) [MCAC30N06Y-](#)
[TP](#) [MCQ7328-TP](#) [NTMC083NP10M5L](#) [NVMFS2D3P04M8LT1G](#) [BXP7N65D](#) [BXP4N65F](#) [AOL1454G](#) [WMJ80N60C4](#) [BXP2N20L](#)
[BXP2N65D](#) [BXT1150N10J](#) [BXT1700P06M](#) [TSM60NB380CP](#) [ROG](#) [RQ7L055BGTCR](#) [DMNH15H110SK3-13](#)