

Silicon N-Channel Power MOSFET

Description

The MPG100N03S uses advanced technology and design to provide excellent $R_{DS(ON)}$. It can be used in a wide variety of applications.

General Features

- ① $V_{DS}=30V, I_D=100A$
- ② Low ON Resistance
- ③ Low Reverse transfer capacitances
- ④ 100% Single Pulse avalanche energy Test

Application

- ① Power switching application
- ② Adapter and charger

Electrical Characteristics

@ $T_a=25^\circ C$ (unless otherwise specified)

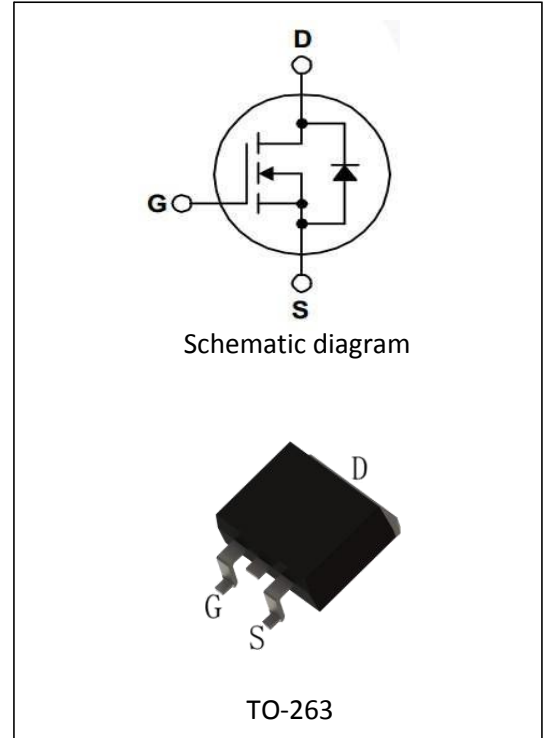

Package Marking And Ordering Information

Ordering Codes	Package	Product Code	Packing
MPG100N03-S	TO-263	MPG100N03S	Tube

Absolute Maximum Ratings:

Symbol	Parameter	Value	Units
V_{DSS}	Drain-to-Source Breakdown Voltage	30	V
I_D	Drain Current (continuous) at $T_c=25^\circ C$	100	A
I_{DM}	Drain Current (pulsed)	400	A
V_{GS}	Gate to Source Voltage	+/-30	V
P_{tot}	Total Dissipation at $T_c=25^\circ C$	120	W
T_j	Max. Operating Junction Temperature	175	$^\circ C$
E_{AS}	Single Pulse Avalanche Energy	700	mJ



Electrical Parameters:

Symbol	Parameter	Test Conditions	Min	Typ	Max	Unit
V _{DS}	Drain-source Voltage	V _{GS} =0V, I _D =250μA	30			V
R _{DS(on)}	Static Drain-to-Source on-Resistance	V _{GS} =10V, I _D =20A		4.2	5.0	mΩ
V _{GS(th)}	Gated Threshold Voltage	V _{DS} =V _{GS} , I _D =250μA	1.0	1.5	2.0	V
I _{DSS}	Drain to Source leakage Current	V _{DS} =30V, V _{GS} = 0V			1.0	μA
I _{GSS(F)}	Gated Body Forward Leakage	V _{GS} = +30V			100	nA
I _{GSS(R)}	Gated Body Reverse Leakage	V _{GS} = -30V			-100	nA
C _{iss}	Input Capacitance	V _{GS} =0V, V _{DS} =25V, f=1.0MHZ		2315		pF
C _{oss}	Output Capacitance			190		pF
C _{rss}	Reverse Transfer Capacitance			11		pF

Switching Characteristics

Symbol	Parameter	Test Conditions	Min	Typ	Max	Unit
t _{d(on)}	Turn-on Delay Time	V _{DD} =20V, I _D =50A, R _G =10Ω		28		nS
t _r	Turn-on Rise Time			21		nS
t _{d(off)}	Turn-off Delay Time			62		nS
t _f	Turn-off Fall Time			32		nS
Q _g	Total Gate Charge	V _{DS} =20V I _D =50A V _{GS} =10V		40		nC
Q _{gs}	Gate-Source Charge			9.2		nC
Q _{gd}	Gate-Drain Charge			14		nC

Source-Drain Diode Characteristics

Symbol	Parameter	Test Conditions	Min	Typ	Max	Unit
I _{SD}	S-D Current(Body Diode)				100	A
I _{SDM}	Pulsed S-D Current(Body Diode)				400	A
V _{SD}	Diode Forward Voltage	V _{GS} =0V, I _{DS} =30A			1.5	V
t _{rr}	Reverse Recovery Time	T _J =25℃, I _F =30A di/dt=100A/us			555	nS
Q _{rr}	Reverse Recovery Charge				4550	μC
*Pulse Test: Pulse Width <= 300μs, Duty Cycle< =2%						

Symbol	Parameter	Typ	Units
R _{θJC}	Junction-to-Case	2.5	℃/W

Package Information

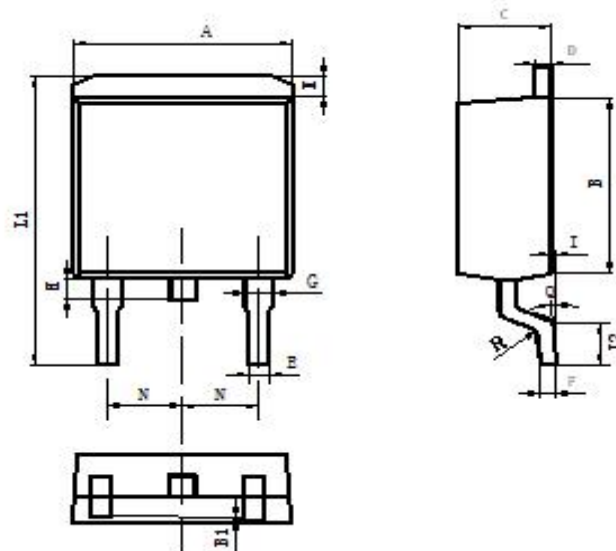

Items	Values (MM)	
	MIN	MAX
A	9.80	10.40
B	8.90	9.50
B1	0	0.10
C	4.40	4.80
D	1.16	1.37
E	0.70	0.95
F	0.30	0.60
G	1.07	1.47
H	1.30	1.80
K	0.95	1.37
L1	14.50	16.50
L2	1.60	2.30
I	0	0.2
Q	0°	8°
R	0.4	0.4
N	2.39	2.69

TO-263 package



NOTE:

1. Exceeding the maximum ratings of the device in performance may cause damage to the device, even the permanent failure, which may affect the dependability of the machine. Please do not exceed the absolute maximum ratings of the device when circuit designing.
2. When installing the heat sink, please pay attention to the torsional moment and the smoothness of the heat sink.
3. MOSFETs is the device which is sensitive to the static electricity, it is necessary to protect the device from being damaged by the static electricity when using it.
4. Shenzhen Minos reserves the right to make changes in this specification sheet and is subject to change without prior notice.

CONTACT:

深圳市迈诺斯科技有限公司（总部）

地址：深圳市福田区华富街道田面社区深南中路4026号田面城市大厦22B-22C

邮编：518025

电话：0755-83273777

X-ON Electronics

Largest Supplier of Electrical and Electronic Components

Click to view similar products for [MOSFET](#) category:

Click to view products by [Minos](#) manufacturer:

Other Similar products are found below :

[IRFD120](#) [IRFY240C](#) [JANTX2N5237](#) [2SK2267\(Q\)](#) [BUK455-60A/B](#) [MIC4420CM-TR](#) [VN1206L](#) [NDP4060](#) [SI4482DY](#)
[IPS70R2K0CEAKMA1](#) [SQD23N06-31L-GE3](#) [TK16J60W,S1VQ\(O](#) [2SK2614\(TE16L1,Q\)](#) [DMN1017UCP3-7](#) [EFC2J004NUZTDG](#)
[DMN1053UCP4-7](#) [SQJ469EP-T1-GE3](#) [NTE2384](#) [DMC2700UDMQ-7](#) [DMN2080UCB4-7](#) [DMN61D9UWQ-13](#) [US6M2GTR](#)
[DMN31D5UDJ-7](#) [DMP22D4UFO-7B](#) [DMN1006UCA6-7](#) [DMN16M9UCA6-7](#) [STF5N65M6](#) [IRF40H233XTMA1](#) [STU5N65M6](#)
[DMN6022SSD-13](#) [DMN13M9UCA6-7](#) [DMTH10H4M6SPS-13](#) [DMN2990UFB-7B](#) [IPB80P04P405ATMA2](#) [2N7002W-G](#) [MCAC30N06Y-](#)
[TP](#) [MCQ7328-TP](#) [NTMC083NP10M5L](#) [NVMFS2D3P04M8LT1G](#) [BXP7N65D](#) [BXP4N65F](#) [AOL1454G](#) [WMJ80N60C4](#) [BXP2N20L](#)
[BXP2N65D](#) [BXT1150N10J](#) [BXT1700P06M](#) [TSM60NB380CP](#) [ROG](#) [RQ7L055BGTCR](#) [DMNH15H110SK3-13](#)