

Data Sheet

- ITEM : ESD FILTER

-PART NO : ICVE21184E150R101FR

1. Scope

- This specification applies to R-varistor for EMI & ESD devices.
- The specification can be modified by documentary agreement between design engineers and customers.

2. Features

- 4 EMI filter lines per device.
- Multilayer chip EMI suppression filter utilizing π -type circuit.
- Very thin (max. 0.55t) and low space consuming(2.03X1.27mm²) size.
- Steep attenuation characteristic plot, Highly effective noise suppression.
- Covers a wide range of frequencies.
- No asymmetrical degradation.
- Simpler fabricating process than diode-type filters.
- Soldering of plating type terminations guarantee high physical and electrical reliability.

3. Applications

- Where EMI filtering in ESD sensitive equipment is required.
- Mobile Phones
- Computers and Printers
- Communication Systems
- Internet Appliances
- PDAs
- Laptop Computers

4. Configuration and Dimensions

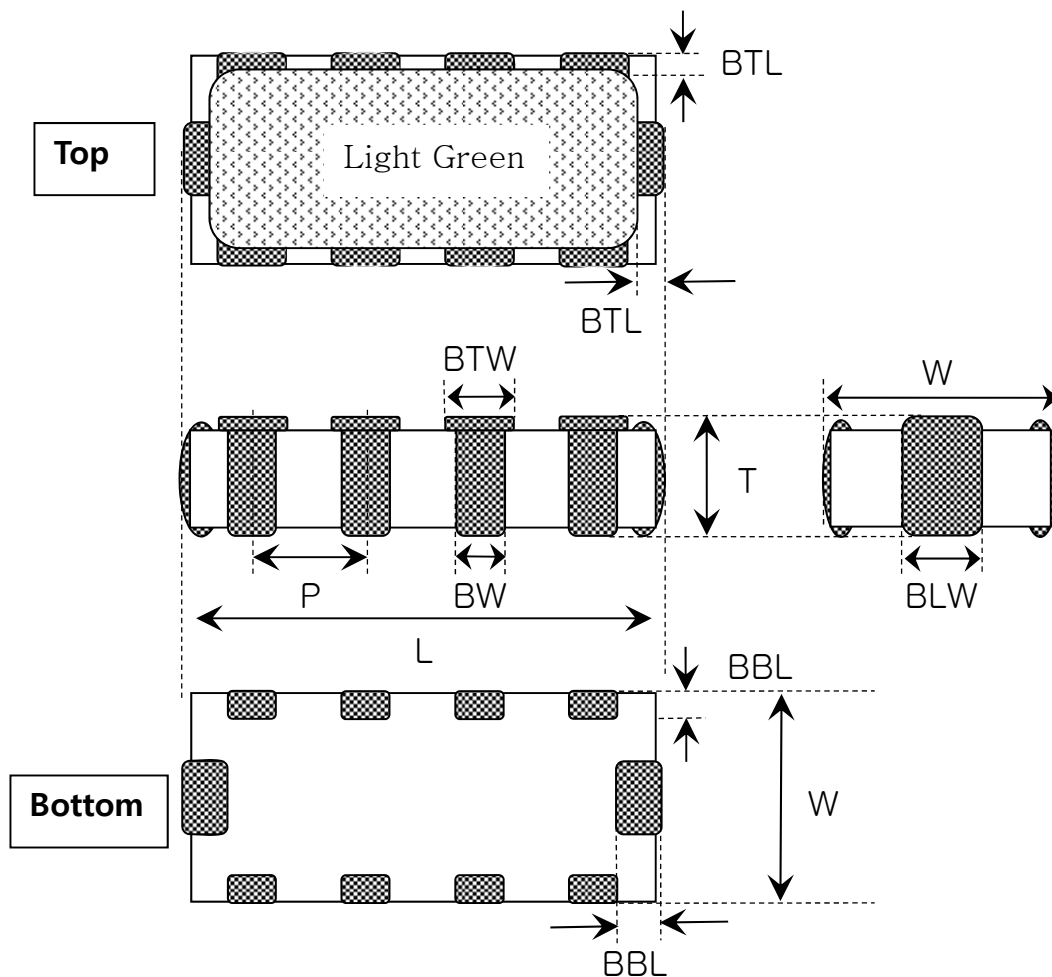

Unit : mm

Symbol	Dimensions	Symbol	Dimensions
L	2.03±0.10	BTL	0.15±0.05
W	1.27±0.10	BBL	0.20±0.05
T	0.55max	BTW	0.32±0.05
P	0.51±0.05	BLW	0.40±0.10
BW	0.30±0.10		

5. Part Number Code

ICVE 21 18 4E 150 R101 F R

① ② ③ ④ ⑤ ⑥ ⑦ ⑧

① SERIES NAME

CODE	PRODUCT NAME
ICVE	EMI Filter Array chip Varistor

② SIZE DESIGNATOR

CODE	SIZE(mm)
21	2.03 × 1.27

③ WORKING VOLTAGE

CODE	VOLTAGE(VDC)
05	5.6
09	9
14	14
18	18

④ NUMBER OF ELEMENT

CODE	NUMBER OF ELEMENT
4E	4 Element

⑤ C line CAPACITANCE

CODE	CAPACITANCE@1MHz(pF)
050	5
070	7.5
150	15
250	25
300	30
500	50

⑥ RESISTANCE

CODE	RESISTANCE(Ω)
R100	10
R500	50
R101	100
R201	200
R401	400

⑦ TERMINATION

CODE	TYPE
F	Electroplate (Pb-free)

⑧ PACKING TYPE

CODE	TYPE
R	Tape & Reel pack

6. Nominal Specifications

Chip Size	ICT Part Number	Leakage Current	Varistor Voltage	Clamping Voltage	Peak Current	Resistance	Capacitance
	symbol	I_L	V_B	V_C	I_{peak}	R	C line
	Units	Amp (max.)	volts	volts (typ.)	Amp (max.)	Ohm (max.)	pF (typ.)
	Test Condition	18V	1mA DC	8/20 μ s @ 1A	8/20 μ s	25°C	0.5Vrms @1MHz
2012	ICVE21184E150R101	<20 μ A	24-36	50	10	100(\pm 30%)	15(\pm 30%)

ICT Part Number	Frequency(MHz)	Attenuation(dB)	Cut-off Frequency(MHz)
ICVE21184E150R101	900-2,000	minimum	Typical(-3dB)
		-20	180

■ TERMINOLOGY

- I_L : Maximum steady state DC operating voltage the varistor can maintain and not exceed 20 μ A leakage current.
- V_B : Voltage across the device measured at 1mA DC current
- V_C : Maximum peak voltage across the varistor measured at a specified pulse and waveform
Pulse Current : 1A , Waveform : 8/20 μ s
- I_{peak} : Maximum peak current which may be applied with the specified waveform without device failure
- C : Device capacitance measured with zero volt bias 0.5Vrms and 1MHz

7. LAND PATTERN

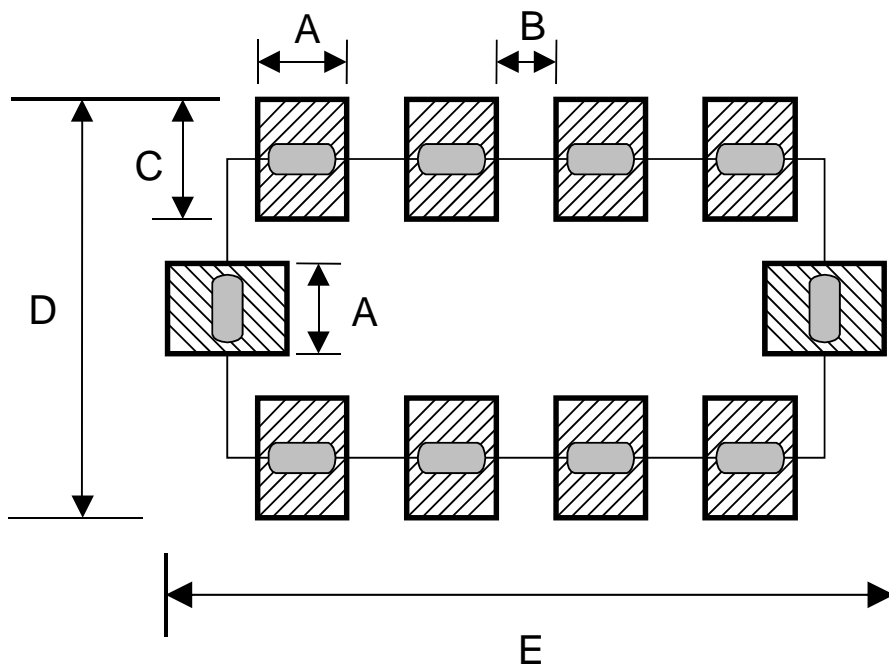

Unit : mm

Size	A	B	C	D	E
2012	0.3	0.20-0.21	0.4	1.6	2.43±0.2

ITEM	P/N	Page
ESD FILTER	ICVE21184E150R101FR	7

8. Reflow condition

1). Recommended soldering profile (Lead-free condition)

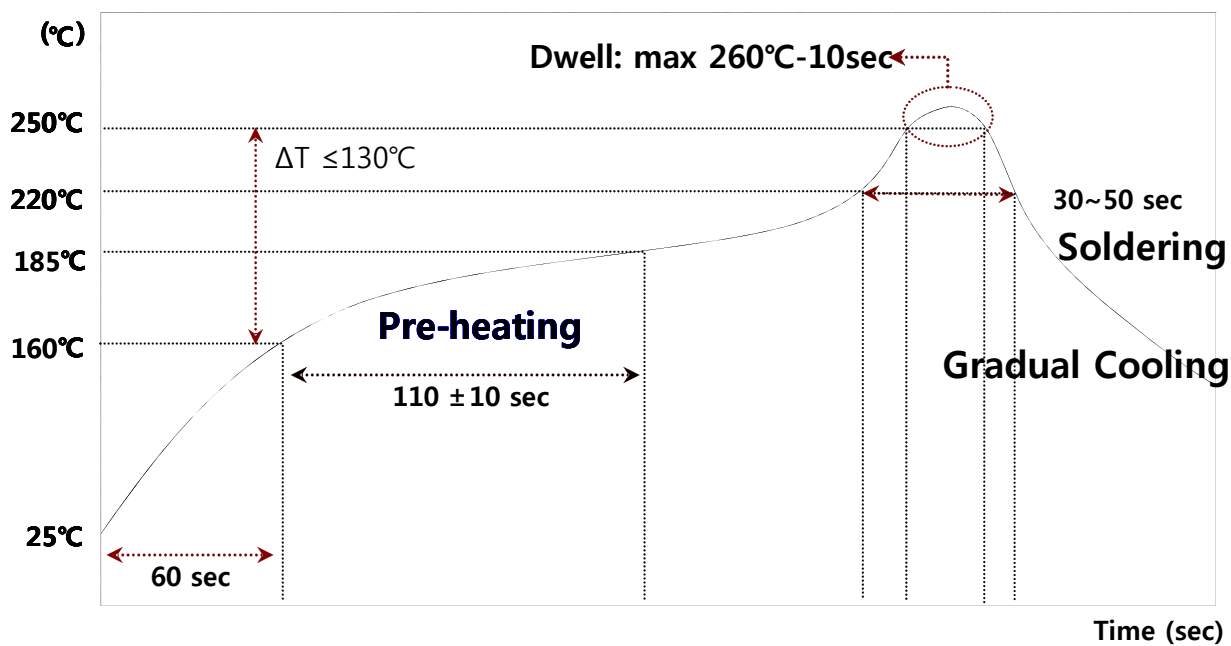

ITEM	P/N	Page
ESD FILTER	ICVE21184E150R101FR	8

9. ELECTRICAL SCHEMATIC

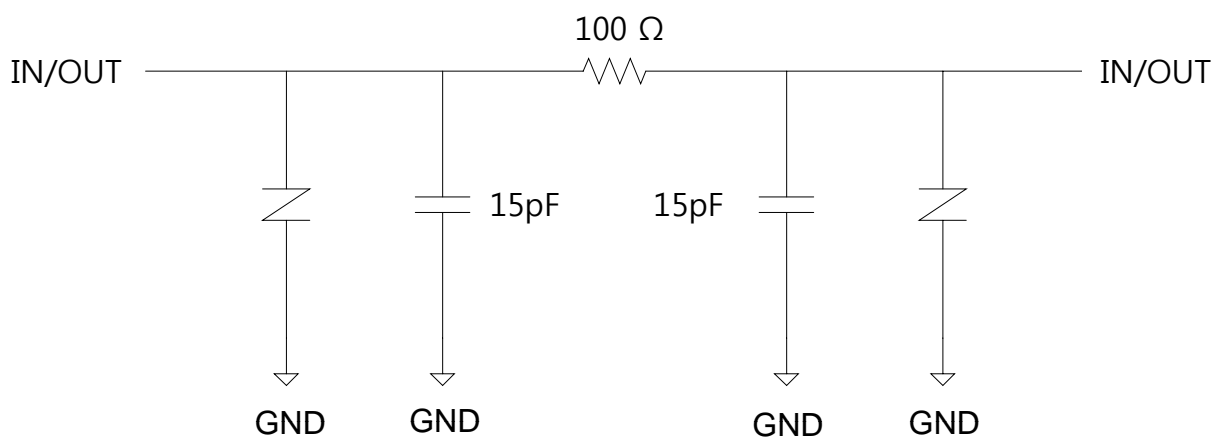
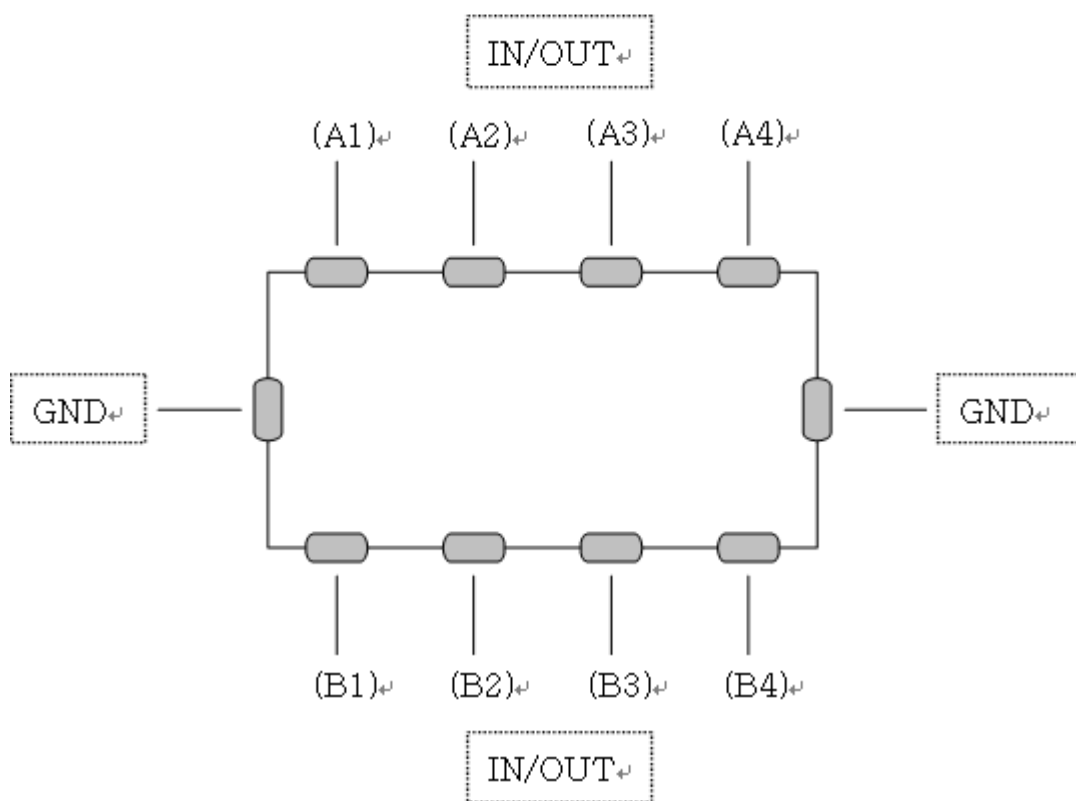

ITEM	P/N	Page
ESD FILTER	ICVE21184E150R101FR	9

11. Typical Characteristics

Filter Performance($T_A=25^\circ\text{C}$, DC Bias=0V, 50ohm Environment)

1) A1-B1, A2-B2, A3-B3, A4-B4

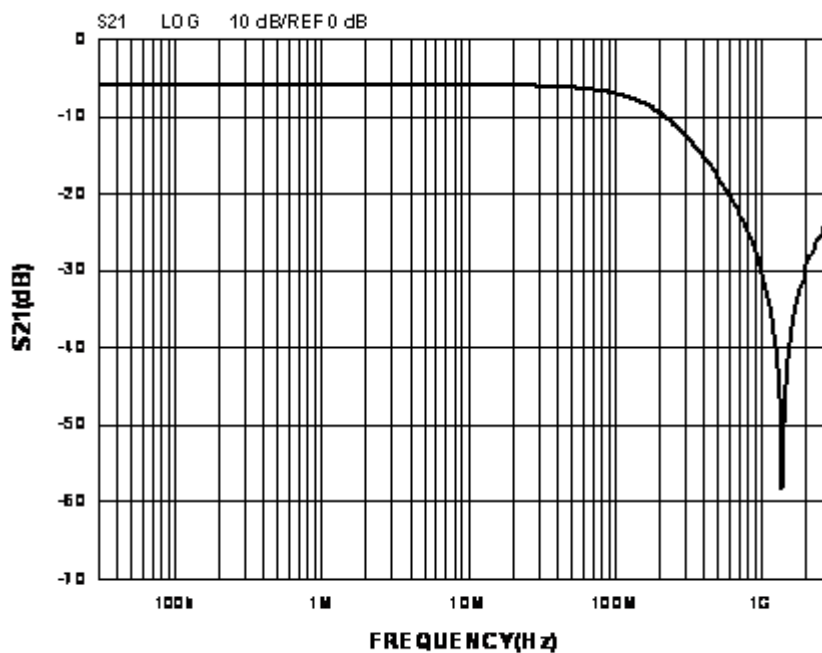

2) Cross talking(A1-B2, A2-B3, A3-B4)

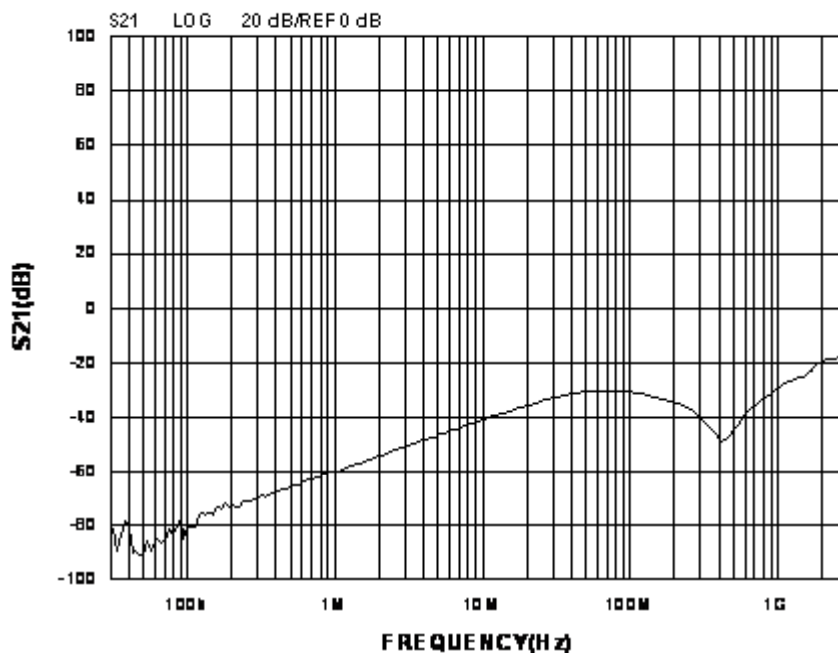

X-ON Electronics

Largest Supplier of Electrical and Electronic Components

Click to view similar products for [EMI Filter Circuits](#) category:

Click to view products by [Moda-Innochips](#) manufacturer:

Other Similar products are found below :

[761280-1](#) [SBSPP1000153MXT](#) [SBSPP1000222MXT](#) [SBSPP1000332MXT](#) [SNZF220DFT1G](#) [CM1442-06CP](#) [EMI8041MUTAG](#) [EMIF06-USD05F3](#) [EMIF06-USD04F3](#) [EMIF03-SIM03F3](#) [EMI7112FCTAG](#) [EMI2180MTTBG](#) [CSPEMI204FCTAG](#) [EMI8043MUTAG](#) [CSPEMI400G](#) [IP3088CX15,135](#) [IP4049CX5/LF,135](#) [LFL181G95TF1D802](#) [LFB213G62CGUE653](#) [LFB182G45CL3D264](#) [LFB321G51CM1D576](#) [ICVE21184E150R101](#) [NFA18SL307V1A45L](#) [1-6609037-5](#) [SBSMP0500474MXT](#) [SBSMP5000473MXB](#) [SBSMP5000683MXB](#) [EMIF05-SK01F3](#) [EMIF02-USB03F2](#) [BNX012H01](#) [BNX022-01L](#) [BNX024H01B](#) [BNX024H01L](#) [BNX025H01L](#) [BNX026H01L](#) [BNX029-01L](#) [NFA21SL806X1A48L](#) [NFL21SP106X1C3D](#) [NFL21SP207X1C3D](#) [NFL21SP506X1C3D](#) [BNX022-01B](#) [BNX023-01B](#) [BNX027H01L](#) [BNX028-01L](#) [NFA21SL307X1A48L](#) [NFA21SL506X1A48L](#) [NFL21SP157X1C3D](#) [NFR21GD1016802L](#) [MEM2012SC151T001](#) [EMI9406MUTAG](#)